

## 1

## Introduction

Fracture is the result of driving a solid beyond its mechanical limit. It is immensely important to know the limit or how materials behave as they approach the limit and the factors that influence them. The failure properties of materials are very distinct from the other properties, such as elasticity, in the sense that their predictions are not always straightforward. For example, typically, fracture strength of a solid has a very wide distribution, and a larger object has lower failure strength than a smaller one of same composition. In brittle materials, fracture is catastrophic, that is, the solid fails without a precursor. It is this intriguing nature of failure phenomena that has led scientists to think about this problem over the centuries. It was Leonardo da Vinci (see Figure 1.1) who apparently first noticed that a longer wire has lower strength. Galileo also recognized the importance of this problem and commented about the limitation of sizes of an object for improvement in its strength (see Figure 1.2).

The understanding of fracture of materials has progressed enormously since those days. However, it is still far from being complete. Present-day understanding of fracture in homogeneous materials is based primarily on linear elastic fracture mechanics which deals with the stress concentration around notches and cracks in a model of linear elastic material. It starts with Griffith's theory (Griffith, 1921) of energy balance. The basic idea here is that when a solid gets strained, and if the elastic energy stored is sufficient to create new surfaces, then a crack becomes unstable and a fracture takes place. The theory was made more accurate by introducing a small plastic zone in front of the crack tip by Irwin and Dugdale (see e.g., Anderson, 1995). This picture, however, cannot handle fracture with plastic deformation and dissipation as it happens in ductile fracture, besides it cannot handle the effect of disorder. Disorder plays a vital role in the behavior of solids, especially before fracture. The strength of a material is determined by the weakest part of it, which leads to the extreme value statistics in failure properties.

After summarizing the basic characterizations of fracture, namely brittle and ductile fracture, the linearity of the stress–strain relationship in the elastic region and subsequent departure to nonlinearity in the plastic region, we go over to the properties of defects in solids in Chapter 3. The lattice defects are quantified in the form of the percolation theory, which gives the limit of high disorder in solids. These characterizations help us understand the nature of extreme statistics led by

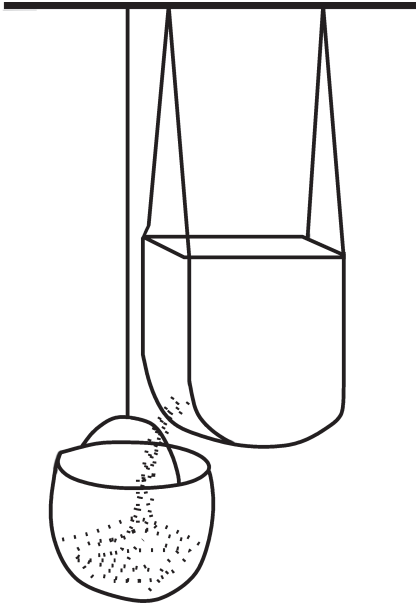
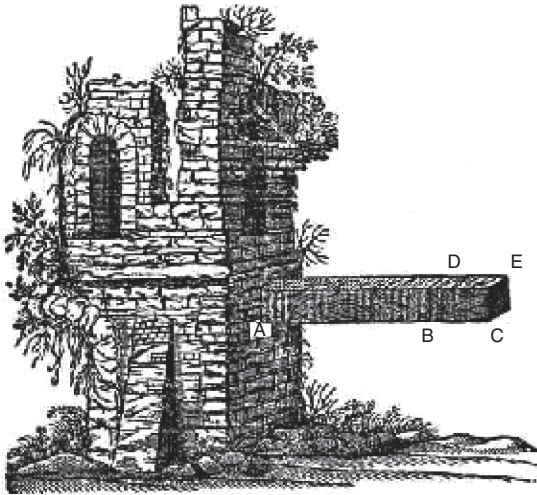

**Figure 1.1** Leonardo di ser Piero da Vinci (1452–1519): da Vinci was a diversely talented person and a leader of the Italian Renaissance movement. He displayed his talent in many areas of arts and science. Best known as a painter (for his famous *Mona Lisa*, *The Last Supper*, *Virgin of the rocks* to name a few), he was also a great engineering designer. However, apart from his well-known inventions and sketches, comparatively less known is his contribution to fracture mechanics. In his experiment titled “Testing the strengths of iron wires of various lengths,” he suspended a basket by an iron wire and slowly added sand to it from a pot hanging adjacent to the basket. The failure point of the wire was noted for its different lengths. In his own words (translated by Parsons, 1939): “The object of this test is to find the load an iron wire can carry. Attach an iron wire 2 braccia long to something

which will firmly support it, then attach a basket or similar container to the wire and feed into the basket some fine sand through a small hole placed at the end of the hopper. A spring is fixed so that it will close the hole as soon as the wire breaks. The basket is not upset while falling, since it falls through a very short distance. The weight of sand and the location of the fracture of the wire are to be recorded. The test is repeated several times to check the results. Then a wire of  $1/2$  the previous length is tested and the additional weight it carries is recorded; then a wire of  $1/4$  length is tested and so forth, noting the ultimate strength and the location of the fracture.” As we will see in Section 4.2, because of the extreme nature of the breaking statistics, the strength of solids decrease with their volume typically as  $1/\ln V$ .

the stress nucleation around defects, which is the topic of discussion in Chapter 4. In addition to the continuum approach, we introduce a discrete element model, called the fiber bundle model, which is a simple one depicting many essential features of failure statistics, including the stress nucleation, and extreme statistics as discussed there.

While disorder in solids governs the failure strength, it also steers the path of the crack. A defect can deflect a propagating crack. Since it is the impression of this



**Figure 1.2** Galileo Galilei (1564–1642): Galileo was an Italian physicist and astronomer who is called the “Father of Modern Science” to honor his many contributions to our present-day understanding of science. Particularly, he produced telescopic evidence of phases of Venus, the four largest satellite of Jupiter, sun spots, and also confirmed the earlier ideas of Copernicus and Kepler that the earth and other planets move around the sun. Because of his conflicting views with the church, he was put under house arrest for the last part of his life. There he wrote his famous book “Two new sciences,” where he described his works on the two sciences “kinematics” and “strength of matter.” There he had observed (see discussions in Section 4.2) the size effects of fracture and described how the natural sizes are limited by their own strengths. In his own words: “From what has already been demonstrated, you can plainly see the impossibil-

ity of increasing the size of structures to vast dimensions either in art or in nature; likewise the impossibility of building ships, palaces, or temples of enormous size in such a way that their oars, yards, beams, iron-bolts, and, in short, all their other parts will hold together; nor can nature produce trees of extraordinary size because the branches would break down under their own weight; so also it would be impossible to build up the bony structures of men, horses, or other animals so as to hold together and perform their normal functions if these animals were to be increased enormously in height; for this increase in height can be accomplished only by employing a material which is harder and stronger than usual, or by enlarging the size of the bones, thus changing their shape until the form and appearance of the animals suggest a monstrosity.” [From: <http://ebooks.adelaide.edu.au/g/galileo/dialogues/chapter2.html>]

crack front that creates the roughness of the fracture surfaces, in a way presence of disorder is responsible for the roughness. It is our everyday observation that fractured surfaces are not smooth but are rough. However, it is not until the pioneering work of Mandelbrot *et al.* (1984) that a universal feature was found in the roughness in fracture surfaces. It was found that the fracture surfaces of various materials were self-affine, meaning they looked similar, no matter to what part of it—small or large—one focuses. Roughness can be quantified by a number called the “roughness exponent”. A surprising observation was that the value was almost

same for various materials. This idea of scale invariance and universality led to substantial activities in this field using the tools of statistical physics and critical phenomena. Many subsequent studies revealed facts both supporting and opposing this universality, also noting a crossover behavior in the exponent value, signifying that the fractured surfaces are not self-affine in all scales after all! Furthermore, an anisotropic feature has also been observed in the roughness properties, distinguishing the direction of crack propagation from the direction perpendicular to it. The experimental observations and theoretical modeling of roughness of fracture surfaces are discussed in Chapter 5.

Another familiar experience with fracture is the accompanying noise. One can experience that in day-to-day activities such as tearing a paper or eating potato chips to failure in geological scale, that is, earthquakes, where the precursor can be lifesaving. The so-called “crackling noise” or emission of acoustic noise is a common fact of fracture, where a portion of energy is released in the form of sound. The intriguing feature, however, once again is the scale-invariant response of the solids in terms of size distributions of acoustic emissions (bursts). When force is applied on a material, some portions (probably weaker) will fail but not the entire solid, since the solid is disordered. When further strained, some weak parts will break again and increase the stress on the remaining part initiating a chain reaction, called an “avalanche.” Since a proportional fraction will be emitted as sound, it can be detected to measure the size of the avalanche. One avalanche may not be sufficient to break the entire solid as the remaining stronger parts may not break. But understandably that part will be highly stressed and a small increase of force may cause an avalanche of much larger size than one usually expects with a small perturbation. Those who are familiar with self-organized criticality, the process may indeed sound like one—there is external forcing and dissipation in terms of acoustic emissions of any size. Under general circumstances, the scale-free distribution of avalanche sizes is a common manifestation of disordered solids. In Chapter 6 we discuss these issues related to the dynamics of fracture.

All structures around us carry finite load for a long time. Even though they may support the load initially, there is no guarantee that they will not fail to do so later. Indeed, imagining fracture as an energy barrier problem, it is easy to see that under the influence of any finite noise, supplied from the environment in the form of, say, temperature, the solid may overcome the barrier and break after a long time. It is therefore vital that one understands the precursors to the so-called “creep rupture”. Similarly, a solid being exposed to cyclic loading may suffer permanent deformation in its structure (fatigue) and can eventually fail below its critical limit. The properties of these subcritical failures are the topics of discussions in Chapter 7. Subcritical failures also show avalanche dynamics and are often quite similar (with same exponent values in case of scale-free size distribution) with those under continuous loading. The chapter also contains relevant discussions of avalanche properties of subcritical failures. In addition to the experimental observations, attempts to model these phenomena theoretically by fiber bundle model are also discussed.

As mentioned earlier, the roughness properties of a fractured surface are due to the trace left behind by the fluctuating fracture front. When a crack is opened by pulling a solid (say, rectangular) from one side (much like opening a book), which is called the mode-I fracture, the fracture front propagates through the disordered solid facing obstacles of different magnitudes. The dynamics of this fracture front is also intermittent and gives the avalanche properties when averaged over time, as well as the roughness properties at one instant of time. The crack opened in this way can be made to remain confined approximately in one plane. This helps in modeling the crack front as an elastic line, which is driven through a disordered medium. Nevertheless, the elastic string model predicts a roughness exponent which does not match with the experiments in smaller length scales. There have been considerable efforts in explaining that theoretically, including the interfacial self-organized crack front propagation model from fiber bundles, the local, long-range dynamics, as well as by considering the loading plate as a semi-infinite elastic plane. Chapter 8 deals with the studies of fracture front propagation.

The dynamics of fracture mentioned so far is mainly the brittle fracture dynamics. However, for many solids the linear stress–strain region is not immediately followed by fracture point. The linearity may be lost for the ductile material beyond a certain stress. In this nonlinear regime, a large strain develops in the system, in response to a much smaller stress. This is due to the appearance and motion of the dislocations. We discuss the dynamics of the ductile fracture starting from the conditions of motion of the dislocation in Chapter 9.

The mechanical fracture is a tensor problem, which can be reduced to an analogous scalar field problem by considering the corresponding electrical breakdown problem. Indeed the two problems are similar in terms of stress concentration around defects. In fact, a mapping between the two problems exists. Like the fiber bundle model for mechanical fracture, the random fuse model has been studied extensively for electrical breakdown. The statistics of avalanche sizes as well as the roughness properties of the fractured surfaces are also studied in terms of this discrete element model. Although the existence of the avalanche dynamics has been claimed to be a finite size effect except for the limit of strong disorder. These issues are discussed in Chapter 10.

Finally, fractures in the largest scale (geological) that we experience are the earthquakes. Study of earthquakes has grown as an independent field of research over the years. It mainly follows the empirical observations about the size and duration distributions of earthquakes, which people have keenly studied over the last past years because of its catastrophic influence. The size distribution of energy emissions and the rate of aftershocks are known to follow scale-free distributions, and the observations go by the same of Gutenberg–Richter law and Omori law, respectively. This is also what is generally seen in much smaller scale of the laboratory in fracturing of rocks. The scale invariance has prompted researchers to think in the line of self-organized criticality for earthquake modeling. The simplest is the spring-block type model, where a train of blocks, connected by linear springs, is slowly pulled over a rough surface. The steady state dynamics of the model shows the intermittent nature that matches with many

observations in earthquakes that are “critical.” One wonders if the universality between earthquake dynamics and laboratory scale fracture propagations is also reflected in the respective models. We take up the earthquake dynamics and its different modeling approaches of fracture and their equivalence in Chapter 11.