

Chapter 2

Communication Paradigms and Literature Analysis

2.1 Vehicular Networks

2.1.1 Terminology and Definition

According to the ISO architecture presented in Sect. 1.3, within a ITSC system there are 4 type of entities: Onboard ITS subsystem of a vehicle, which is usually denoted as On Board Unit (OBU), Roadside ITS subsystem, typically denoted as RoadSide Unit (RSU), central ITS subsystem, and Personal ITS subsystems (e.g., smart devices). In this book, a network that includes all these entities is referred as a vehicular network. In this type of network, several communication technologies and communication protocols can be used at the same time, thus realizing a truly heterogeneous network. Since an endpoint of the communication is always given by a vehicle (OBU), while the other endpoint varies depending on the application, communications in a vehicular network are typically denoted with the acronym V2X (Vehicle-to-Device), where the “X” denotes any kind of entity discussed above.

When a vehicular network is exclusively formed by OBUs and RSUs, it is customary referred as vehicular ad-hoc network (VANET). A VANET is less heterogeneous than a generic vehicular network, and typically based on a single dedicated communication technology (DSRC-like) and a limited set of communication protocols. When both endpoints of a communication are OBUs, the communication is referred as Vehicle-to-Vehicle (V2V), while when the first endpoint is an OBU and the second endpoint is an RSU or a centralized server, the communication is denoted as Vehicle-to-Infrastructure (V2I) or Infrastructure-to-Vehicle (I2V), depending on the direction of the information flow.

2.1.2 Key Challenges in Vehicular Networks

A node member of a vehicular network cannot be considered as a mere communication device (OBU), but as a complex entity jointly constituted by the OBU itself and the vehicle where the OBU is installed on. This entity is characterized by a series of unique features and compelling challenges that should be accounted by any communication protocol designed for inter-vehicular communications.

2.1.2.1 Advantages

A vehicle is equipped with computing and sensing capabilities (e.g., GPS transceivers, accelerometers, cameras) able to provide information about the dynamic state of the vehicle and the surrounding environment [1], [2], [3], [4]. This actively collected information can be integrated with a considerable amount of side-information derived by the constrained mobility of the vehicles, that are forced to move along defined roadways, or by the information pro-actively provided by the driver itself (i.e., path-planning). A vehicle also provides a virtually unlimited amount of stored energy, which is available for sensing, communication and computation tasks, while other types of mobile wireless networks (i.e., wireless sensor networks, cellular networks) are usually energy-constrained. Another peculiarity of vehicular networks is that information is typically exchanged between entities without any user interaction, like in Machine-to-Machine (M2M) networks, thus allowing to predict communication patterns [5]. These combined factors imply that a node of a vehicular network can achieve a higher awareness level than in traditional wireless networks, which can be exploited by communication protocols to improve several functionalities, such as topology management, congestion control [6], handover management [7] and performance optimization [8].

2.1.2.2 Limitations

The main drawbacks of vehicular networks are related to the high vehicle mobility, which requires a huge effort for maintain up to date network topology maps. The problem is complicated by the high variability of the environment in which vehicular networks operate. A lot of different configurations are possible, ranging from highways where relative inter-vehicle speeds of up to 300 km/h may occur, and the spatial density is typically low, to city roads where relative inter-vehicle speeds can be in the order of few tens of km/h and spatial density can be high, especially during rush hour. On the one hand, when the vehicular spatial density is low, networks are often partitioned in sets of disconnected clusters; on the other hand, when the density is high, the wireless channel can be congested and affected by interference.

The variability of the environment is not only important from a topological point of view, but also from the perspective of the physical wireless channel. Vehicles

can run in a desert countryside, inside a tunnel, or in a urban canyon studded with skyscrapers. Furthermore, because of their metallic nature, surrounding vehicles have a huge impact on the number of multi-path reflections experienced by the receiver. Also the antenna radiation pattern is highly influenced by its placement with respect to the vehicle (i.e., inside, on the roof). Moreover, high relative speeds produce Doppler shifts, and other vehicles induce shadowing phenomena [9].

Finally, the third category of issues that affect vehicular networks is more abstract and directly influenced by the nature of the vehicular market and applications requirements. The market has a global scale or, at minimum, a country-wide scale, and therefore also a vehicular network shall assume a dimension comparable with that of a country-wide road infrastructure. However, for most applications, interesting information is local, and can be retrieved by interacting with neighbor vehicles, or with active points of interest and service providers, positioned in the nearby. In other words, even if vehicular network can have a huge scale in terms of geographical extension and number of nodes, they provide (mostly) localized services. This bipolar nature is manifested in the network architecture that it is often a combination of centralized and decentralized network topologies.

Common communication CPEs have a limited lifetime, which rarely overcomes the threshold of 10 years, indeed it is typically much shorter. Conversely, the lifetime of a vehicle often overcomes the threshold of 10 years and can also be significantly longer. This lifetime mismatch shall be accounted when designing a vehicular communication technology, and an OBU shall be reliable and easily upgradable in order to not excessively impact on the vehicle maintenance cost. Furthermore, a longer lifetime implies a slow vehicles substitution rate and a slow adoption rate of off-the-rack vehicular communication technology. This is big issue since most ITS applications and services are effective only if the number of equipped vehicles in a given spatial region (i.e, the spatial density) is sufficiently high, or, in other words, greater than a certain threshold. This is a typical example of a *chicken-and-egg* problem, which poses serious issues on the appealing of communication-based ITSs system [10]. To mitigate such a problem, it is necessary to increase the adoption rate of ITS equipment, a result that can be obtained by pursuing three main strategies illustrated below.

- Enforcing proper rules and policies for the adoption of ITS equipment. For example, the European Commission has mandated the adoption of the e-Call platform in all new vehicles, starting from 2015.
- The development of suitable after-market devices, installable on old vehicles, to speed up the transition.
- Reusing as much as possible some widely available technologies, such as cellular networks or standard WiFi, which can be used to provide services to vehicle without dedicated equipment.

2.1.3 Network Topology

With the expression *network topology* it is possible to refer both to the **physical** network topology, given by the nodes and by the physical wired or wireless links between them, or to the **logical** network topology constituted by a network of virtual nodes and virtual links set over the real links.

2.1.3.1 Physical Network Topology

The physical topology of a mobile wireless network is determined by the nodes' positions and by the directionality and transmission range of the adopted communication technologies. With the exception of a partial control that can be achieved by employing power control and/or smart antenna techniques, once chosen the communication technology the designer cannot modify the network topology, as it cannot control or predict the nodes' movements.

Vehicular networks are mobile wireless networks where it is possible to have a better topology control, for two reasons: as seen in Sect. 2.1.2, the vehicles' movements are constrained by the road infrastructure and at some extent predictable; moreover, vehicles are often equipped with heterogeneous communication technologies, thus leading to an additional degree of topology freedom. On the basis of their impact on network topologies, today's vehicular communication technology can be classified in three main groups, illustrated in the following.

- Unidirectional broadcast communication technologies, such as FM-based digital radio broadcast, where communications can only happen between a centralized service center through a network of radio stations. In this case the network has always a star topology.
- Technologies with a limited transmission range (less than 1km) supporting direct communications between vehicles and broadcast transmissions. Such a category includes DSRC-like technologies like IEEE 802.11p, CALM M5, ETSI G5 and traditional WiFi standards (IEEE 802.11a/b/g/n), in either ad-hoc or direct mode. In this case, the physical topology is strictly correlated to the vehicles' mobility and to the communication range. According to many studies, cars naturally tend to form isolated clusters of vehicles [11]. The cluster size, the cluster lifetime and the number of clusters depends on the environment. Within a cluster, vehicles assume a highly-dynamic mesh topology, with a highly-variable degree of connectivity, ranging from line topology to fully-connected topology. The presence of RSUs does not alter significantly the network topology, however they can help in connecting isolated vehicle clusters.
- Technologies with a wide area coverage, not supporting direct communications and broadcast transmissions. WiMAX [12], [13] and all current cellular technologies, starting from GSM to LTE [14], [15], fall in this category. In this case, the physical topology is quite simpler since from a link-layer perspective all communications are directed to the base station, and therefore the network topology is constituted by

a series of star-topology networks. Obviously, a node out of coverage is intrinsically isolated.

Clearly, when vehicles are equipped with both technology types, the two categories of topology merge together, leading to hybrid topologies.

We observe that the introduction of the upcoming LTE Advanced (LTE-A) [16], [17] standard will drastically change the panorama and will form a category alone. In fact, LTE-A promises to bring some direct communication and broadcast transmission capacities, thus achieving the properties of both second and third categories.

2.1.3.2 Logical Network Topology

The concept of logical network topology can be ambiguous, as—depending on the context—in some cases it consists of overlays created at low layers of the ISO/OSI stack (MAC and routing), while in other cases it is more convenient to define logical topologies at higher layers, such as the application layer. When a vehicular networks collapses in a pure VANET constituted only by OBUs and RSUs, application and routing levels often coincide. In these cases, it is possible to analyze them together. Conversely, in more complex vehicular networks that encompass heterogeneous technologies and include remote nodes or mobile terminals, it is difficult to keep a coherent topological vision at low layers, and it is more convenient to focus on the application layer. Greater details on topological overlay at application layer will be provide in Sects. 2.3 and 2.4, which are devoted to VANETs.

It is a costly operations maintain a logical topology view on highly mobile networks such as as vehicular networks. On the one hand, protocols that proactively build a topology map require a constant heartbeat traffic, which is expensive in terms of resource usage and can lead to congestion in highly dense networks. On the other hand, protocols that actively (on demand) construct a topology map have to face many obstacles. A non exhaustive list of logical topology that characterize VANETs is reported below.

- No topology knowledge—In most dissemination applications based on local broadcast, there are no significant advantages on actively build up the network topology. Therefore in this case the sender simply has no knowledge of the network topology.
- Source-originated tree-based topology—In this case each node of the network build its own topology tree starting from itself (the root). Such a tree can be constructed only when necessary, in order to reduce the overhead costs due to maintenance. In most cases the tree-based topology collapse in a star topology where the nodes only know 1-hop distant nodes. This partial knowledge of the network can be exploited in unicast or broadcast multi-hop dissemination protocols.
- Cluster-based topology—In this case, the logical topology keeps the same structure of the underlining physical topology. Most cluster protocols requires to individuate some supernodes, such as the clusterhead and some kind of gateways with special function, as which of routing the packets towards other clusters in the nearby.

In this family of protocols, within the cluster there is a shared knowledge of the network,

- Mesh topology. In this case, all network nodes share a common vision of the network. Also in this case, the topology is temporary and can be proactively constructed by means of a multi-hop routing protocol.

2.2 Vehicle-to-X Communications

2.2.1 Key Features of a V2X Communication Protocol

As a result of the numerous issues described in Sect. 2.1, it is difficult to design a unique V2X communication protocol able to cope with the extreme complexity of a vehicular network, in terms of mobility, environment dynamism, technology heterogeneity, and to satisfy the often contradictory requirements of vehicular applications. For this reason, V2X communications are based on a set of V2X communication protocols, each of them able to deal with specific types of scenarios and applications.

A communication protocol could be analyzed in two different manners, by observing the service it provides or by considering its inner characteristics (e.g., its communication mechanisms). The service type provided by a V2X protocol is fully specified by the following parameters [18].

- Target applications.
- The nature of communicated data (size, real-time requirements, bulk data).
- The direction of the data flow (unidirectional or bidirectional).
- The quality of service that can be fully specified by three aspects: latency, end-to-end throughput and packet success ratio.
- The circumstances under which the communication is initiated (the trigger event).
- The type and number of involved endpoints (OBU, RSU, centralized server of mobile terminals).

The communication mechanism is characterized by the following factors.

- The traffic pattern—it is considered as unicast when the communication involves only two endpoints, while on the contrary a broadcast traffic pattern involves a single traffic source, and the destination nodes are all the network nodes. A geocast traffic pattern can be considered as a localized broadcast protocol, where the destination nodes are not all the network nodes, but only the nodes positioned in a precise and constrained geographical area.
- The network model, determined by the number of communication hops (measured at the link layer). In a single-hop protocol, the communication involves only two nodes. In a multi-hop protocol the communication involves a larger number of nodes, that can act either as source, destination or relay. A multi-hop protocol allows to extend the dimension of the network and to solve coverage problems, but

it complicates network operation and reduce the performance in terms of latency and throughput in comparison to a single-hop solution.

- Transaction type and transaction frequency.
 - Protocols based on frequent periodic messages sent multiple times per second, such as the Cooperative Awareness Messages (CAM) used by the CAM Basic Service [19]. CAMs are periodically broadcasted by the facility layer at a given frequency satisfying both road safety application requirements and transport and network layer requirements (*network heartbeat*). The CAM frequency may be determined by the communication management entity, taking into account the supported road safety application’s operating requirements, transport layer requirements and the current channel load.
 - Event-triggered messages suddenly sent upon a certain event happens, with an unpredictable frequency, but usually in the order of once a second or less. A significant example is represented by the Decentralized Environmental Notification Messages (DENMs) used by the DENM Basic Service [20].
- Transaction size.
 - Small: constituted by single message.
 - Medium: constituted by multiple messages—but the transaction can be still completed in a time smaller than the links lifetime.
 - Large: the transaction cannot be completed during a link lifetime, but it shall involve several links or technologies.
- Session type.
 - Individual messages with a loose session concept (as in broadcast protocols).
 - Unicast local session, generally with OBUs or RSUs.
 - Unicast session with a remote endpoint, which can be a server or a mobile terminal. The remote session can be maintained across several V2I communication sessions, or relying on wide area networks technologies.
- Protocol type.
 - IP based protocol. Often V2X communication protocols natively rely on IPv6 routing protocol to have greater efficiency, larger addressing space and better mobility support.
 - Protocol based on dedicated custom messages, such as the WAVE Short Message Protocol (WSMP).

2.2.2 Vehicle-to-X Communication Paradigms

By combining the inner properties of a V2X communication protocol and the characteristics of the provided services, it is possible to define four main communication paradigms: V2V Local Broadcast, V2V Multi-Hop Dissemination, I2V

Local Broadcast, V2I Bidirectional Communications [21]. Conversely, Beaconing, Geobroadcast, Unicast routing, Advanced information dissemination and Information aggregation, are media independent communication paradigms, in theory, but in practice most of them are effective only with dedicated communication technologies (i.e., IEEE 802.11p or similar) [18].

Beaconing is a special case of vehicle-originated broadcast, used to continuously informing neighboring cars of each other's current position, heading, and speed. Communication is unidirectional and single-hop, hence only neighbors in the communication range of the sender are able to receive its messages. Information exchange through beaconing has a local value and serves as the foundation for cooperative applications aimed at collision avoidance. Beaconing is effective only if performed with dedicated DSRC technologies, with native broadcast support. The aforementioned CAM Basic Service is a potential consumer of a beaconing communication service.

Geobroadcast is another case of unidirectional vehicle-originated broadcast used to inform cars positioned in a certain spatial region in the same area of the sender. Geobroadcast is typically based on V2V multi-hop dissemination mechanisms, and messages from one vehicle are relayed by other vehicles to reach destinations that are outside the source's communication range. When the number of hops is low, this paradigm can be used to support hard safety applications such as emergency vehicle approach, slow vehicle, emergency electronic brake lights and forward collision warnings. These represent the most time-critical and safety-critical category of connected vehicle applications, since they are used to warn drivers of imminent-crash hazards. Geobroadcast dissemination could also be used for soft safety purposes such as the distribution of hazardous road and traffic information. Geobroadcast messages are typically sent upon a certain external event, and they often requires very low latency, especially when used for hard-safety purposes. The aforementioned DENM Basic Service is a potential consumer of a Geobroadcast communication service.

With *I2V Local Broadcast*, vehicles receive local broadcasts from the roadside infrastructure, in support of safety, mobility or sustainability applications. Infrastructure-originated broadcasts are used to disseminate data that are relevant to all vehicles in the vicinity of a specific road infrastructure location, where an RSU is installed. Therefore, it can be implemented through DSRC transceivers deployed along the roadside. However, it can also be implemented using cellular, satellite, or digital radio broadcast services, to reach all the vehicles in a large geographical region. These broadcasts use individual, single-hop I2V messages, involving small transactions, with frequent transmission. The quality of service requirements depend on the target application (traffic controller signal phase and timing information, dangerous road condition information).

Unicast routing has the purpose to transmit data through the network to a specific destination, which can be positioned in the nearby of the sender or remotely. Every endpoint type (OBU, RSU, central server, mobile terminal) can assume either the role of sender or destination. The communication may consist of only a single hop, or route messages over multiple hops toward the destination. These messages are

generally unicast local sessions with low time criticality, low transaction frequency and small transactions, without any refined control or management mechanism.

Advanced information dissemination or multi-RSU session is required to transfer large quantities of data or to execute transactions that take considerable time, which cannot be accommodated within a single encounter between a moving vehicle and one roadside ITS station, but must be maintained across several V2I/I2V unicast communication sessions with a remote server. These transactions are single-hop, with low time-criticality and low frequency. It is necessary to connect with a service provider across a network, but the logical communication session needs to persist across multiple paths, signal between the OBU and a series of RSUs offering access to the backhaul. The persistence may be provided at the application level, the transport layer or the network layer. Example applications would be downloads of large infotainment/media or map update files, some concierge services or continuous web surfing.

Finally, *V2I Bidirectional Communications* are required by many mobility applications, such as navigation, Internet access for browsing or email, electronic transactions for purchasing goods or services, and media download, but also to exchange messages between vehicles, through infrastructure applications servers. Bidirectional communications mode can be supported by dedicated DSRC technologies, but more often with wide area networks, such as cellular networks or WiMAX.

2.3 Centralized Client/Server Technologies

Traditionally proposed architectures are based on a centralized approach, where one or more central servers have the responsibility to manage all position updates and queries from involved users—related, for example, to a specific point of interest, to neighborhood discovery or to path planning. In order to manage a huge number of active users at the same time, with a high quality of service (QoS), usually those solutions require relevant computational power on the server side, and are provided by big companies such as Google and TomTom.

Google Latitude has been introduced by Google in 2009 [22]. It is a location-aware Web/mobile application which allows a mobile phone user to share his/her current location with a group of people, i.e., both real and social friends (Fig. 2.1). By means of his/her Google Account, the location corresponding to the user's cell phone is mapped on Google Maps. The user can control the accuracy and details of what other users can see. An exact localization can be allowed, or it can be limited to identify only the city. Also, a location can be manually entered. For privacy reasons, the localization feature can be turned off. Recently, Google added the possibility to share the user's daily check-ins with Latitude friends, thus merging the functionalities of another application, namely Google Places.

Another example of centralized system is TomTom's HD Traffic, a real-time traffic service which tries to give accurate and up-to-date traffic information. HD Traffic is part of TomTom's LIVE Services, which deliver information to drivers, helping them to save time, money and fuel. In order to be able to provide such an accurate

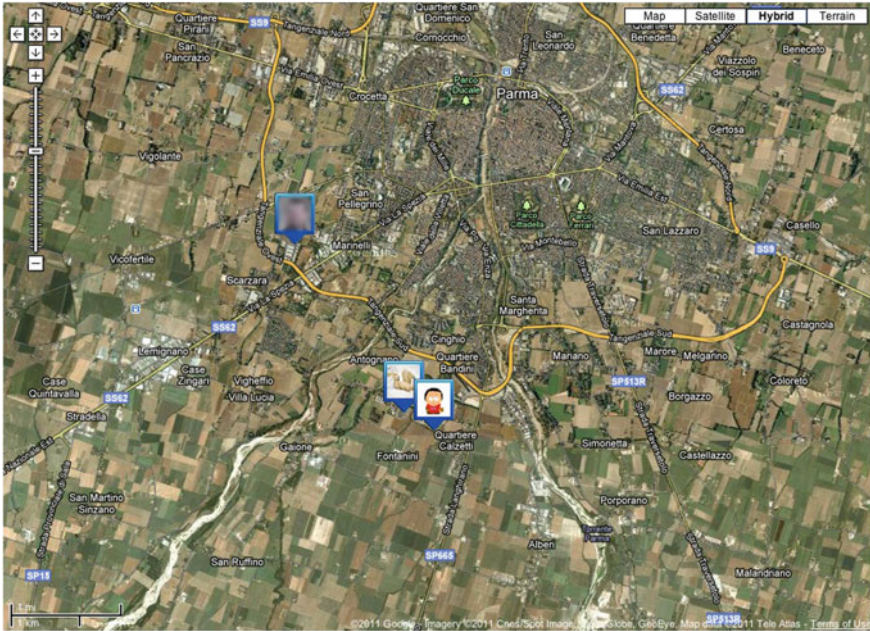

Fig. 2.1 Google Latitude application (Web version) showing friend locations on a map view

real-time information on all major and secondary roads, TomTom’s patented HD Traffic technology uses, above all, traffic data generated by the movement patterns of mobile phones inside vehicles, which are collected anonymously from mobile carrier networks. These patterns are then combined with anonymous data from TomTom devices, as well as other traditional sources of traffic information, to provide one of the most advanced traffic information services. Traffic information is relayed in real-time and securely to TomTom devices, thanks to Vodafone Italy’s patented Machine to Machine (M2M) solutions [23], and includes a SIM card with a GPRS connection, which is embedded into the navigation device. Processed information and evaluation results, such as traffic status, accident and road monitoring, are then available on TomTom devices or through a Web interface (Fig.2.2).

Among academic research projects, MIT’s CarTel [24] combines mobile computing and sensing, wireless networking, and data-intensive algorithms running on servers in the cloud to address these challenges. CarTel is a distributed, mobile sensing and computing system using phones and custom-built on-board telematics devices—one may think of it as a “vehicular cyber-physical system”. A CarTel node is a mobile embedded computer coupled to a set of sensors. Each node in the system gathers and locally processes sensor readings, before delivering them to a central portal, where data are stored in a database for further analysis and visualization. CarTel provides a simple query-oriented programming interface, handles large amounts of heterogeneous data from sensors, and copes with intermittent and

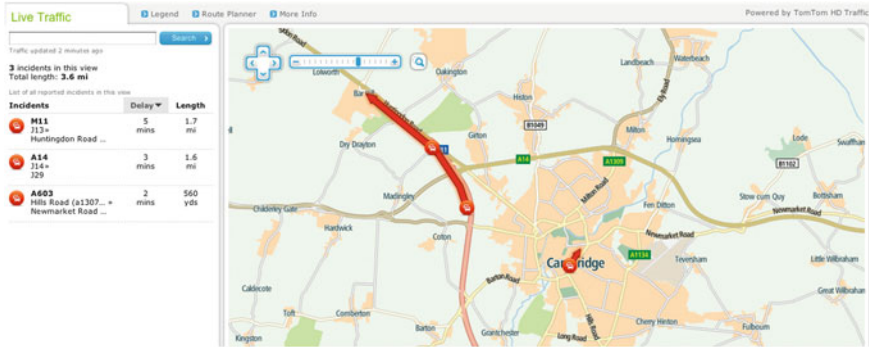

Fig. 2.2 TomTom’s HD Traffic Web Interface

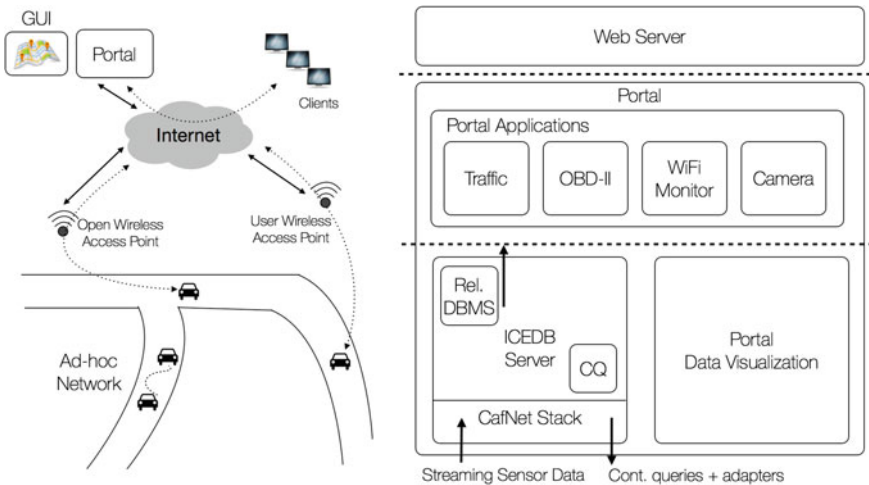

Fig. 2.3 MIT’s CarTel architecture

variable network connectivity. CarTel nodes primarily rely on opportunistic wireless (e.g., Wi-Fi, Bluetooth) connectivity to the Internet, or to “data mules”, such as other CarTel nodes, mobile phone flash memories, or USB keys, to communicate with CarTel applications running on a Web portal. A delay-tolerant continuous query processor, called ICEDB, allows to specify how mobile nodes should summarize, filter, and dynamically prioritize data. Figure 2.3 illustrates the system architecture, with the different components of the platform. Cars collect data as they move, and log them to their local ICEDB databases. As connectivity becomes available, data on cars is delivered to the Web portal, where users can browse and query it by means of the visual interface.

These examples of centralized solutions are only a small subset of the huge amount of existing solutions. They give an idea about problems associated to location based



Fig. 2.4 Screenshot of Waze's Live map

solutions, the amount and heterogeneity of information that could be potentially involved, and the number of simultaneously active users that participate in such a system.

Particularly innovative is Waze [25], a *social driving* mobile application. By connecting drivers to one another, Waze helps people create local driving communities that work together to improve the quality of everyone's daily driving. That might mean helping them avoid the frustration of sitting in traffic, cluing them into a police trap, or shaving five minutes off of their daily travel by showing them new routes they never even knew about (Fig. 2.4). In October 2012, the Waze community consisted of 28 million drivers. New features are periodically added, according to user preferences. For example, the features released in Waze 3.5 (Driving to a restaurant with friends, Picking up your spouse, Let the kids know you'll be home for dinner) have been introduced taking into account an Omnibus survey of 1,000 American drivers, commissioned by Waze, which found that over 50 % of drivers regularly pick up friends and family.

2.4 Decentralized and Peer-to-Peer Systems

Due to the progressive improvement of Internet connections, and in particular of mobile devices capabilities, during the last decades the research community focused on decentralized architectures, and in particular on peer-to-peer (P2P) overlay networks, which are characterized by highly distributed algorithms for sharing data and resources like computing cycles, storage, and bandwidth. Target applications were (and still are) file sharing, social networking, live and on demand streaming, as well as decentralized geolocation services. Every time a peer wants to know a specific information, e.g., which peers are located in a certain area, it does send a number of lookup queries to a subset of the known peers. Such queries are routed within the overlay network, towards those nodes which may store the desired information.

Distributed localization is a clear example of *geocollaboration service*, usually implemented by recursively dividing the 2D space into smaller areas, in order to assign each peer the responsibility of a space region. Instead of employing a number of centralized servers (either dedicated or selected among participating nodes) to carry the load for the entire network, the peers share the load of indexing and searching data that refers to its area. The idea of hierarchical partitioning comes from the indexing of data structures for multidimensional data sets, such as the R-tree [26], which is widely used in centralized databases. R-trees are tree data structures used for spatial access methods, i.e., for indexing multi-dimensional information such as geographical coordinates, rectangles or polygons. Such an approach has been used in both research and real-world applications, for example to store spatial objects such as restaurant locations, or the polygons which typical maps are made of—streets, buildings, outlines of lakes, coastlines, etc. Moreover, it allows to quickly answer queries such as “*find all museums within 2 km of my current location*”, “*retrieve all road segments within 2 km of my location*”, or “*find the nearest gas station*”. The key idea of the data structure is to group nearby objects and represent them with their minimum bounding rectangle in the next higher level of the tree. Since all objects lie within this bounding rectangle, a query that does not intersect the bounding rectangle cannot intersect any of the contained objects. At the leaf level, each rectangle describes a single object, while at higher levels it describes the aggregation of an increasing number of objects. This can also be seen

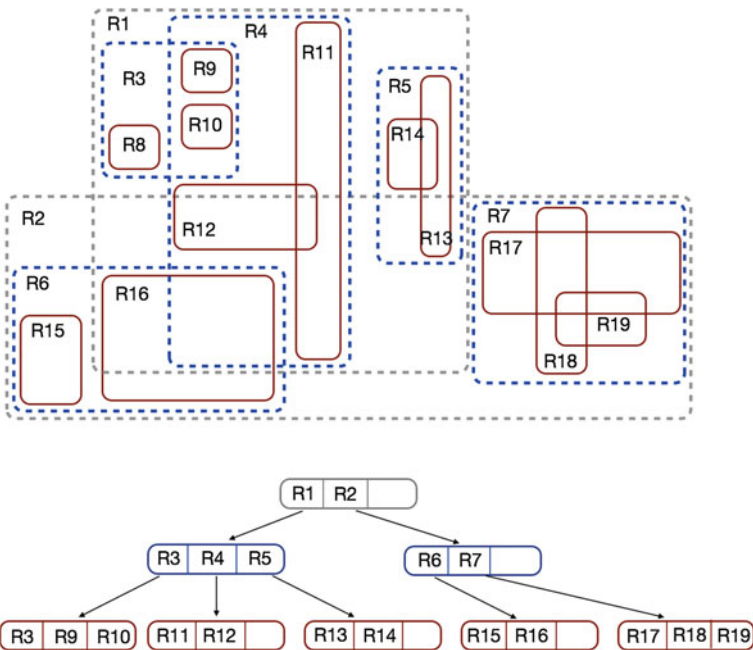

Fig. 2.5 Simple example of an R-Tree with 2D rectangles

as an increasingly coarse approximation of the data set. Scheme in Fig. 2.5 shows a R-Tree examples in the 2D.

Examples of general-purpose hierarchical peer-to-peer schemes supporting geo-collaboration services are HZSearch [27], DPTree [28], DiST [29]. These and other research works propose strategies for supporting complex queries over multi-dimensional data, such as “select five available buildings closest to the airport” [30], [31], [32].

According to the use of wireless technologies and system designs, Tsao et al. categorized decentralized traffic information systems into four different architectures: single-tier VANET, single-tier P2P over VANET, single-tier infrastructure-based P2P, and two-tier VANET/P2P [33]. Such categories are illustrated in Fig. 2.6.

In single-tier VANETs, vehicles communicate with each other through Inter-Vehicular Communication (IVC), and periodically broadcast their current speeds and positions to neighboring vehicles. A part of the traffic information a vehicle receives may also be propagated to its neighbors through broadcast messages. Based on the received messages, a vehicle can generate traffic reports.

In a single-tier P2P over VANET, vehicles form an application-layer P2P overlay network on top of the VANET. The P2P overlay can be either unstructured or structured. Vehicles share their resources (i.e., traffic information) and retrieve resources from others through the P2P overlay. The application-layer P2P overlay communication relies on the routing protocol of the underlying VANET. The key difference between the P2P over VANET architecture and the previous architecture is the traffic information lookup. In the previous approach, a vehicle floods a query message to all neighboring vehicles within the IVC range. In this architecture, a vehicle explicitly

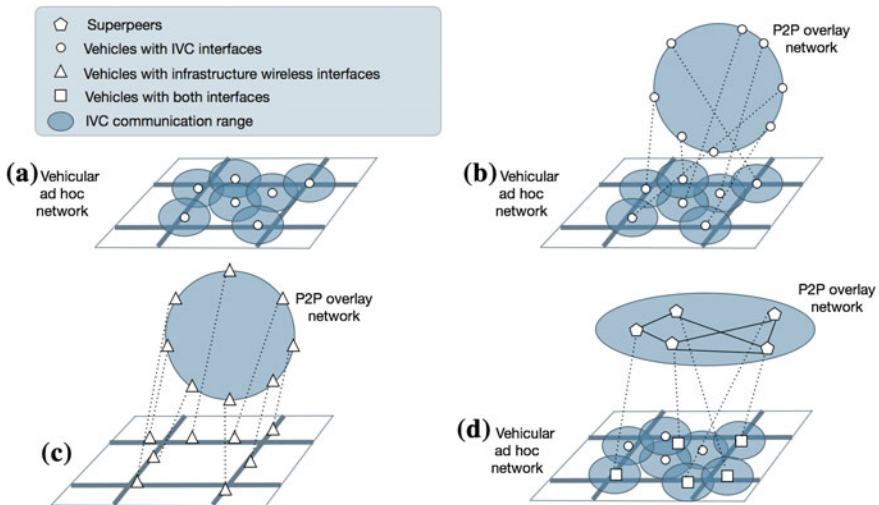

Fig. 2.6 Decentralized traffic information systems: **a** single-tier VANET; **b** single-tier P2P over VANET; **c** single-tier infrastructure-based P2P; **d** two-tier VANET/P2P

forwards the query by exploiting the application-layer P2P lookup mechanism and the VANET routing.

Another single-tier architecture involves forming a P2P overlay through an infrastructure network. Vehicles are required to have a broadband wireless interface to access the infrastructure network. Vehicles communicate with each other through infrastructure communication instead of ad-hoc communication. Also in this case, the P2P overlay could be unstructured or structured.

A two-tier VANET/P2P architecture exploits both VANET and P2P technology. In the low tier, vehicles form a VANET via inter-vehicle communication to exchange traffic information. Some vehicles are selected to form a high-tier P2P overlay through a broadband wireless infrastructure. These vehicles are called superpeers and serve as a bridge between the high-tier and low-tier networks to handle message exchanges and lookups. According to Tsao et al., the two-tier architecture achieves much higher lookup success rates than VANET-based systems and outperforms single-tier infrastructure-based P2P systems in terms of success rate, latency, and maintenance cost [33]. Nevertheless, we claim that in many cases the single-tier infrastructure-based P2P architecture has several advantages. In the following of this section we discuss some noticeable example.

The specific problem of geographic localization is addressed by Globase.KOM (Geographical LOcation BAsed SEArch) [34], which adopts an enhanced tree-based P2P overlay. The main focus is to enable search over all peers in a defined geographical area, which can be either circular or rectangular. A peer is enabled to search for a node with a particular location, or for the geographically closer peers. Together with the information about its geographical location, a peer can publish any other data describing the service it offers (e.g., a video stream from a webcam), the object it represents (e.g., restaurant, police station, sightseeing, gasoline station), or some additional information (e.g., menu, prices, opening hours). For example, users can find the closest gasoline station or can find all restaurants in some area and see their menu or video streams from webcams.

The Globase.KOM scheme is based on supernodes, i.e., powerful nodes, with best network connectivity, which tend to stay online for a long time. Supernodes are responsible for indexing all nodes/services in one clearly defined geographical area. Other nodes in the network simply offer and consume services, with no additional responsibilities. The idea is that the world projection is divided into disjoint, non-overlapping zones. Each zone is assigned to a supernode (located inside the zone itself), which has to collect, store and maintain the overlay/underlay contact addresses of all nodes in that zone (Fig. 2.7).

Active peers in Globase.KOM perform three main location-related operations, i.e., area search, address lookup, and discovery of the geographically closest nodes. Area search is performed using the SEARCH message, which includes a description of the geographical area (center and radius), plus metadata describing the targeted service/object. When a superpeer receives a SEARCH query from one of its peers, it calculates the searched ellipse onto the map projection. Next, it checks if that ellipse intersects the zone it is responsible for. Figure 2.8 illustrates an example of area search. A peer in the zone of superpeer B sends a SEARCH message containing a

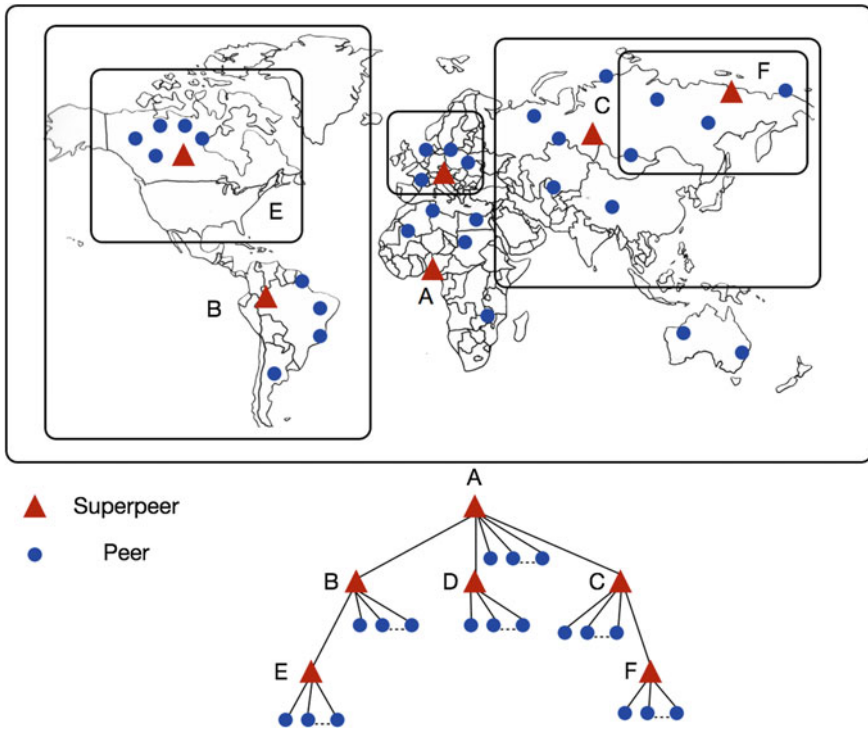

Fig. 2.7 Globase.KOM: division of world projection in multiple non-overlapping zones

description of the marked zone. As the zone does not intersect the zone for which superpeer B is responsible, the SEARCH message is forwarded to the superpeer A. In the end, superpeers A, C, and D reply with the list of the matching results.

Every superpeer maintains the contact addresses of the peers inside its zone (but not those of the peers which are into inner zones), of the superpeers responsible for inner zones (called child nodes), of its parent in the tree, of the root superpeer, and of interconnected superpeers. Each normal peer maintains the contact addresses of the parent superpeer, of the root superpeer, as well as an interconnection list and a cached list of already contacted peers. Peers/Superpeers are identified by their unique PeerID (Fig. 2.9), which contains the GPS coordinate of the node, if it is a supernode, the zone it is responsible for, and a random part, in order to support the existence of more than one peer at the same location.

The address lookup operation is used to determine the IP address and port of a peer, given its geographical location. Each superpeer knows the IDs/locations of all nodes it is responsible for. Therefore, a lookup operation basically means routing the LOOKUP message to the superpeer responsible for the peer with the given location.

When a peer wants to find the closest peer, it first calculates the closest border of the zone it belongs to. This is possible by using the ID of the parent superpeer,

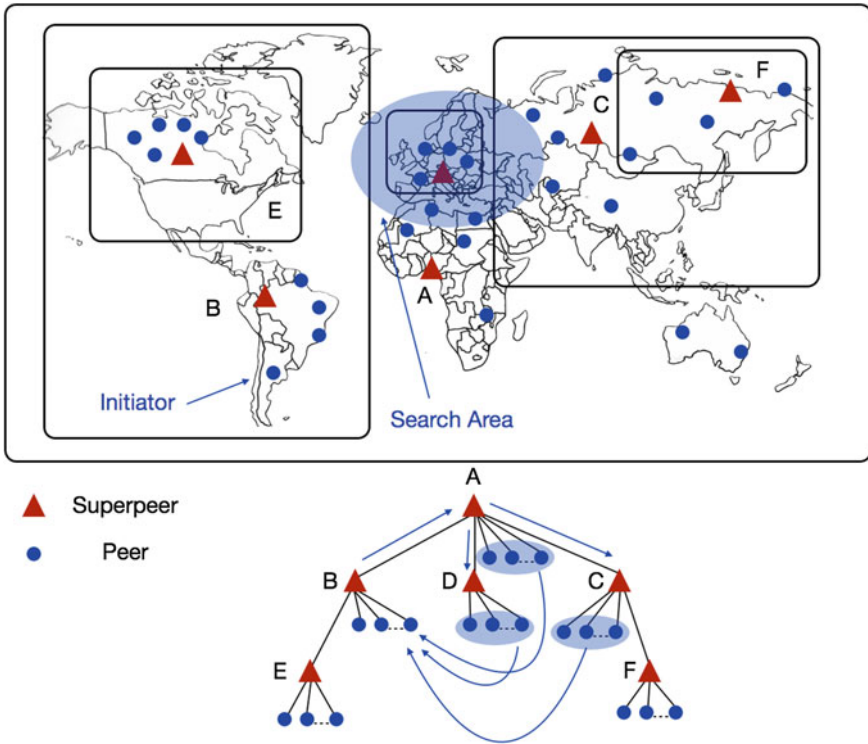
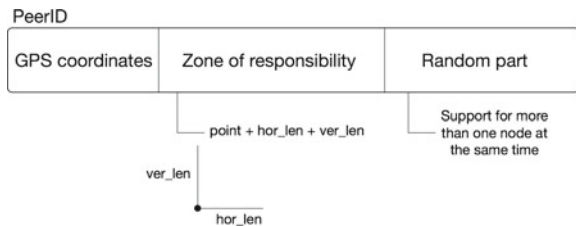

Fig. 2.8 Globase.KOM: example of Area Search procedure

Fig. 2.9 Globase.KOM: structure of PeerID



which contains a vector representation of the zone. Then, the peer sends a FIND CLOSEST message to its parent superpeer, containing the calculated distance to the closest border of the zone.

Another architecture, called GeoP2P [35], still performs a hierarchical partitioning of the 2D geographic space, but adopts a fully decentralized peer-to-peer overlay scheme, with overlay maintenance and query routing performed without super or special peers. The system consists of large number of peers, distributed across a 2-dimensional space with rectangular boundary. Each peer is placed in the 2D space, and is responsible for providing information which is relevant to its location. A peer

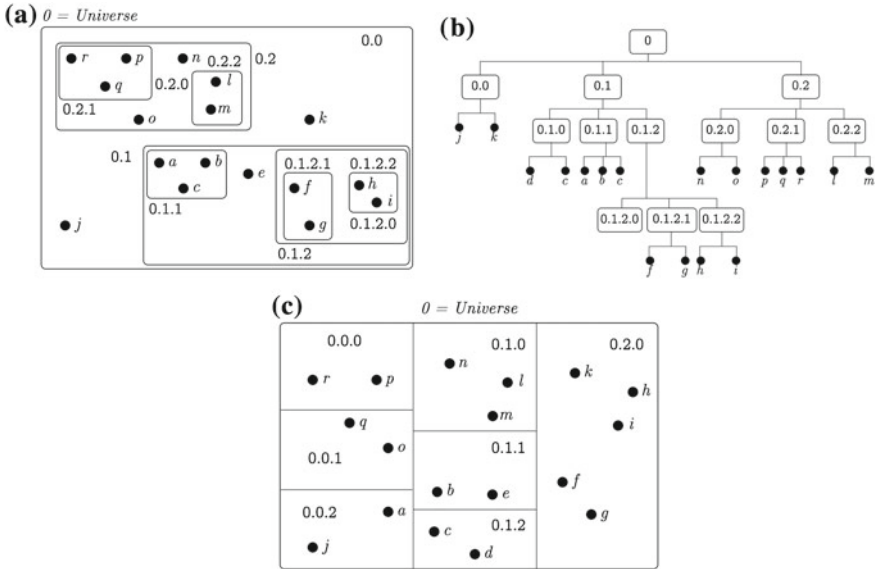

Fig. 2.10 GeoP2P: **a** Zoning by clustering; **b** Zoning Hierachy; **c** Zoning by splitting

can be associated to a single sensor, such as a surveillance camera, or to a database which contains information about the local environment, such as a hotel, or a gas station. Each piece of data stored in the overlay is updated independently. Additionally, any peer can be interested in any region in the space and send a query. The purpose of the overlay network is to route queries to relevant peers.

Also in GeoP2P, the universe is hierarchically divided into zones. At the top level of the hierarchy, the zone representing the universe is divided into a number of sub-zones, each one being further divided into sub-sub-zones at the next level of the hierarchy, and so on. Thus the zones can be conceptually organized into a tree, where the root of the tree represents the universe and each tree-node represents a zone. Figure 2.10a illustrates an example division of the universe, and the corresponding tree representation is shown in Fig. 2.10b.

Each peer maintains a routing table which lists all the other peers it knows. To resolve a query about any region in the universe, a peer tries to find a peer that belongs to the leaf zones intersecting the query region. To do that, each peer needs to have some structured knowledge to cover the globe, such that for any zone, it either knows all the peers belonging to that zone, or at least knows some peers which know more about that zone. Any query can thus be either resolved or forwarded to a peer that has better knowledge of the queried region.

The routing table is organized in d rows, one for each level of hierarchy, from 1 to d . Each row maintains information regarding $k - 1$ sibling zones of that level, plus some information for the self-zone. For each sibling zone, the table maintains the network address of one (or more) contact peer, associated with the rectangular

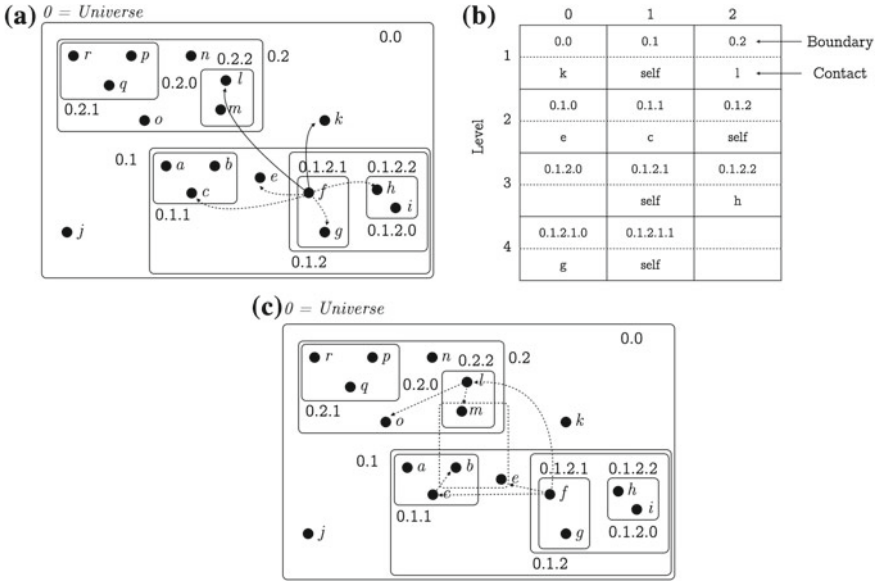

Fig. 2.11 GeoP2P: **a** overlay neighbors of peer f ; **b** routing table of peer f ; **c** routing path of a range query

boundary (coordinates of bottom-left and top-right corner) of the zone. Siblings can be organized into columns, based on the segment of the zone identifier which corresponds to the branching at that level. For the self-zone, only the zone boundary must to be maintained, and it can be stored in the corresponding column based the identifier of the self-zone. Level d stores the information regarding the leaf zone, and there the siblings are individual peers instead of zones. Thus, in this case the coordinates of the peers are stored, instead of the rectangular boundaries. Figure 2.11b shows an example routing table of a peer. The corresponding overlay neighborhood is illustrated in Fig. 2.11a.

The main drawback of the hierarchical approach is that peers representing higher level regions may become bottlenecks for query routing, and possible points of failure for the whole system. Moreover, none of the state-of-art solutions has been demonstrated to work in presence of mobile peers.

Rybicki et al., with Peers on Wheels [36], PeerTIS [37], and GraphTIS [38] proposed P2P architectures where participating cars are peers organized in a Distributed Hash Table (DHT), to receive and distribute useful information to improve the vehicle travel time using dynamic route guidance. In PeerTIS, roads are divided into segments, each with a unique ID that is used as key in the DHT. The main idea is that each node is responsible for a certain part of the ID space and, consequently, for a certain number of road segments. GraphTIS was designed to overcome the main issue of PeerTIS, i.e., that the geographical coordinates of road segments are not uniformly distributed over the key space (it was observed that, in a realistic simulated

scenario, almost 40 % of all peers do not maintain any data at all). In GraphTIS, graph partitioning algorithms are employed to dissect the graph into a number of (almost) equally sized disjoint sub-graphs. The aim is still to minimize the effort for looking up a group of road segments. Whenever a query crosses a boundary between two peers, it must be transmitted over the network, causing network traffic and increasing the query latency. Thus, the partitions should be formed in such a way that typical queries touch as few partitions (and hence as few peers) as possible, i.e., the partitions should be chosen in a way that minimizes the number of cut graph edges. It is known that optimal graph partitioning is NP-hard. In GraphTIS, a combination of graph growing and the Kernighan-Lin algorithm [39] are used. The hierarchical partitioning and labeling is constant for a given map, so it is pre-calculated once, before the system starts running, and stored along with the street map data. At runtime each peer maintains all (key, value) mappings for the sub-graph represented by one node in the partitioning tree.

2.5 Enabling Technologies

As we have seen in Chap. 1, the approach followed by international standardization bodies, notably ETSI and ISO, consists in adopting an open communication architecture embracing a mix of protocols and technologies, either dedicated or general purpose. In Table 2.1, we have summarized the main characteristics of principal communication technologies that can be currently used in ITSs. We have considered the dedicated IEEE 802.11p standard, a mix of general purpose existing technologies including IEEE 802.11, and two generations of cellular networks, namely UMTS and LTE.

In such a table, IEEE 802.11p is the unique dedicated technology and therefore it natively offers most of the features required by ITSs applications, including support for all broadcast and V2X communication capabilities, including multihop. It is also boasts a small latency and it allows to perform communications without a preemptive setup of the network. This is a key feature for hard-safety applications that require a low delay. As today, the low market penetration is the most critical issue of IEEE 802.11p.

WiFi (with this term we refer to classical IEEE 802.11a/b/g standards) shares some characteristics with IEEE 802.11p, including native support for broadcast and V2X communication capabilities, even if at less reliable degree than IEEE 802.11p. On the other hand, WiFi suffers of the limited data range and of the limited mobility support, due to the high network setup time. However, WiFi can exhibit a very high market that can be exploited for both in-vehicles and V2X communications.

UMTS and LTE exhibit characteristics that are almost orthogonal with respect to WiFi and IEEE 802.11p. In fact, both UMTS and LTE exhibit ubiquitous coverage, high mobility support and V2I capabilities. However, they lack support for direct V2V communications, and they support local broadcast only through dedicated protocol specifications, notably Multimedia Broadcast Multicast Service (MBMS) for UMTS

and evolved Multimedia Broadcast Multicast Service (eMBMS) for LTE [40], [41]. However, the deployment of MBMS and eMBMS is totally dependent on the mobile operators’ willingness. Currently, the diffusion of eMBMS is pretty scarce, and, at the best of our knowledge, there are no implementations of MBMS. In terms of performance, there is a clear gap between UMTS and LTE, in terms of data rate, end-to-end delay and setup type. While LTE copes with the exigences of a large number of ITSs applications, including safety dedicated tasks, UMTS can be employed only for a limited class of services.

2.5.1 Cellular Networks

The cellular networks deployed today are based on a heterogeneous mix of different generations of communication technologies, starting from 2G, and including 3G, 3.5G and LTE. This heterogeneity and the frequent generation upgrades has historically discouraged the use of cellular networks in ITSs applications, in particular in USA, where car owners and state DOTs feared to constantly upgrade equipment in vehicles and intersections, respectively.¹

There is a pervasive diffusion of compatible devices (smartphones, tablets, OISs) and the existing network infrastructure guarantees a worldwide coverage and it is constantly upgraded by operators. This means that there is no need for additional

Table 2.1 Performance indicators of main ITSs communication technologies

Feature	IEEE 802.11p	WiFi	UMTS	LTE
Type	Dedicated	General purpose	General purpose	General purpose
Market Penetration	Low	High	High	Potentially High
Bit Rate	3–27 Mbit/s	6–54 Mbit/s	2 Mbit/s	up to 300 Mbit/s
End-to-end delay	10 ms	10 ms	50–100 ms	10 ms
Setup time	0	a few seconds	100 ms up to seconds	50-100ms
Maximum Range	1 km	0.1 km	10 km	30 km
Coverage	Intermittent	Intermittent	Ubiquitous	Ubiquitous
Mobility support	Medium	Low	High	Very High
V2V Local Broadcast	Yes	Yes	Through server	Through server
V2V Multihop	Yes	Yes	Through server	Through server
V2I Bidirectional	Yes	Yes	Yes	Yes
I2V Local Broadcast	Yes	Yes	Partially (MBMS)	Partially (eMBMS)

¹ <http://www.itsa.org/industryforums/connectedvehicle>.

dedicated infrastructures. Moreover, current generations of cellular technology (3G, 3.5G and LTE) offers low latency and high throughput, and may operate with vehicle speed up to 300Km/h. For these reasons, cellular technologies are included in both ETSI and ISO architectures, and are already used in vertically integrated ITS applications (i.e., insurance company black box), or to provide TIS-related services [42].

However, current cellular technologies are affected by a series of technical limitations that make them unsuitable to fit the requirements of safety-related applications, which play a pivotal role in ITS. The main limitations, that emerge clearly from Table 2.1, are related to the lack of support for broadcast communications and V2V communications and for the significant latency, which is too high for most hard-safety ITS applications (e.g., collision avoidance). The upcoming LTE-Advanced (LTE-A) generation promises to be a game changer. LTE-A is committed to provide technologies for high data rates and system capacity. Further, LTE-A was defined to support new components for LTE, to meet new communication demands coming from the ITS community and from Machine-to-Machine (M2M). On the one hand, LTE-A will provide more advanced local broadcast eMBMS mechanisms, thus bringing benefits to ITS communications. On the other hand, LTE-A will provide Device-to-Device (D2D) communication capabilities to be exploited in V2V services. In D2D mode, terminals may communicate directly with their neighbors, thus bypassing the data plane of cellular base stations (denoted as eNodeB in LTE), while maintaining their leadership role in the control plane [43].

2.5.2 *WiFi and WiFi Direct*

The IEEE 802.11 standard specifies physical and MAC layers to set up wireless local area networks (WLANs) [44]. Although its first release was published in the far 1997, it is not yet an obsolete technology. In order to accommodate the introduction of new functions, the standard has been continuously modified, with specific amendments processes. An up-to-date version of the standard, aggregating several of these amendments, was released in the 2007 and denoted as IEEE 802.11-2007 [45]. In particular, the *a*, *b*, and *g* amendments were introduced, respectively as the chapter 17, 18, and 19, while the amendment *e*, introducing the support for Quality of Service (QoS) at MAC level, has been merged with chapter 9 of the standard. Two important amendments, IEEE 802.11p [46] and IEEE 802.11n [47], have been recently included in the standard, and the IEEE 802.11ac amendment will be standardized soon.

The basic building block of an IEEE 802.11 network is the Basic Service Set (BSS), a group of STATIONS (STAs) that may communicate with each other. IEEE 802.11 offers different opportunities to build a BSS. For instance, nodes can form an Independent BSS (IBSS) with no central coordination authority, or, as in environments with infrastructure (i.e., AP) be part of an infrastructure BSS, with an individual identification number. In both cases, the channel access mechanism is based on a Carrier Sense Multiple Access with Collision Avoidance (CSMA/CA)

strategy. When STAs operate in an IBSS, the network operates in ad-hoc mode, which is the only form that allows to perform V2V communications. However, the ad-hoc mode is affected by two main limitations, one concerning synchronization issues, and the other affecting communication security.

Synchronization issues are related to the intrinsic characteristics of the CSMA/CA mechanism. In fact, in order to correctly transmit and receive data, all the STAs within the same IBSS have to be locked to a common clock [45]. In order to reach this goal, the standard defines a suitable mechanism, known as Timing Synchronization Function (TSF) [44]. In the case of infrastructure-based networks, all the STAs are synchronized with the AP's clock. On the other hand, in ad-hoc networks it is necessary to employ a suitable distributed algorithm to synchronize the STAs. In all the cases, synchronization information is obtained through the transmission of a special frame, denoted as beacon. It can be observed that in the case of ad-hoc networks the synchronization issue limits the maximum number of nodes that can belong to the same IBSS [48]. Some issues are related to the nature of the Wi-Fi Protected Access (WPA e WPA2) mechanisms that provide the security layer of the IEEE 802.11 protocol [49]. In fact, if applied in ad-hoc networks, WPA introduces significant scalability problems, as it requires to exchange a number of keys directly proportional to the number of STAs.

In order to overcome these limitations, the WiFi Alliance has recently realized a new protocol, denoted as WiFi Direct [50], with the goal to overcome the numerous limits of the ad-hoc mode. However, the WiFi Direct mode has currently a low market share, since it is available in a small number of top level devices. Therefore, it is not possible to realize an application with a large diffusion based on WiFi Direct.

WiFi Direct devices build topologies based on groups, following the classic concept of BSS. Each group has a leader which can be considered an access point to the network. One of the main peculiarity of WiFi Direct with respect to the classic IEEE 802.11 standard is the fact that the access point of the network can be dynamically chosen. The leader of the group is dynamically designed and not fixed, unlike infrastructure-based networks. For this reason, all WiFi Direct devices should be able to become group leaders, supporting the functionality of device discovery and mechanisms for the coexistence with other types of IEEE 802.11 networks. In fact, WiFi Direct has been conceived to be used simultaneously to a infrastructure-based network, thus yielding to a higher level of scalability than pure ad-hoc networks. However, WiFi Direct is strongly limited by the fact that it cannot be directly used to perform multihop communications. To overcome such a limit, it is possible to use the advanced functionalities of WiFi Direct, as the support for multiple groups and to transverse communications. Unfortunately, most of these features are not supported by the devices available on the market.

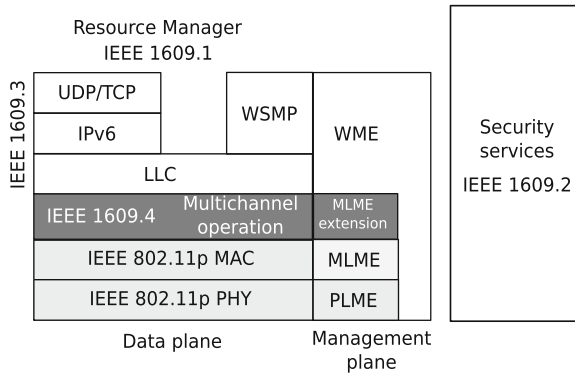

Fig. 2.12 Protocol stack jointly defined by the IEEE 1609 and the IEEE 802.11p standards

2.5.3 IEEE 802.11p and WAVE

The IEEE has realized a totally new protocol stack, commonly denoted as WAVE, which copes with the IVC requirements: highly dynamic and mobile environment, message transmission in an ad-hoc manner, low latency, and operation in a reserved multi-channel frequency range. As shown in Fig. 3.4, WAVE maintains the traditional ISO/OSI protocol stack [51] and is composed by a collection of standards, namely, IEEE 802.11p the IEEE 1609 standards family [52]. The latter—which has been already discussed in Sect. 1.3.3—defines higher layer services, such as system architecture, security, resource management and communication model [53], while IEEE 802.11p is focused on physical and MAC layers.

In November 2004, the IEEE 802.11p Task Group was formed to develop an amendment to the IEEE 802.11 standard, to add *wireless access in vehicular environments (WAVE)*, by defining enhancements to IEEE 802.11 including data exchange between high-speed vehicles and between vehicles and roadside infrastructure, in the licensed ITS band of 5.9 GHz (5.85–5.925 GHz). IEEE 802.11p was considered for vehicle-based communication networks—in particular, for toll collection applications, vehicle safety services, and commerce transactions via cars. The ultimate vision was a nationwide network enabling communications between vehicles and roadside access points or other vehicles. The last approved amendment of IEEE 802.11p was incorporated in IEEE 802.11 standard [45], published in 2012 (Fig. 2.12)

The IEEE 802.11p standard differs from the existing IEEE 802.11a standard in three main aspects [54]: (i) the definition of BSS; (ii) some details of the physical layer; (iii) the MAC layer. In the WAVE mode, data packets transmission is only allowed to occur within an IBSS, which is established in a fully ad-hoc manner, without any need for active scanning, association or authentication procedures. A node that initiates an IBSS is called provider, while a node that joins an IBSS is called user. To establish an IBSS, the provider has to periodically broadcast on CCH an IBSS announcement message, which includes the WAVE Service Advertisement (WSA).

The latter message contains all the information identifying WAVE applications and associated network parameters, necessary to join an IBSS (e.g., the ID, the SCH index, and timing information). A node should monitor all WSAs on CCH to learn about the existence and the operational parameters of the available IBSSs.

The IEEE 802.11p physical layer is an amended version of the IEEE 802.11a specifications, thus it is based on OFDM modulation. It mandates the use of 10 MHz channels, which offer a greater resistance with respect to the channel delay spread, thanks to their double guard time (1.6 μ s). The 10 MHz frequency leads to halved data rates, and the maximum sustainable data rate becomes 27 Mbit/s. We remark that, differently from the IEEE 802.11a, whose use was forbidden for several years in Europe, the use of IEEE 802.11p is already allowed, regulated by the ETSI European Standard 202 663 [55].

The IEEE 802.11p MAC layer has the same Enhanced Distributed Channel Access (EDCA) core mechanism of introduced in the IEEE 802.11e amendment [56]. EDCA maintains the distributed approach of the CSMA/CA protocol as in legacy DCF, but introduces four Access Categories (ACs), each one defining a priority level for channel access and having a corresponding transmission queue at the MAC layer. Each AC in the queue behaves like a virtual STA, and it follows its own DCF algorithm, independently contending with the others to obtain the channel access. Each i -th AC has a set of distinct channel access parameters, including Arbitration Inter-Frame Space (AIFS) duration and contention window size ($CW_{\min}[i]$ and $CW_{\max}[i]$). The AIFS has the same meaning of DIFS parameter in the DCF algorithm but the different duration, and it is defined as:

$$T_{\text{AIFS}}[i] = T_{\text{SIFS}} + \text{AIFSN}[i] \cdot T_{\text{SLOT}},$$

where $\text{AIFSN}[i]$ is an adimensional parameter different for every AC. Clearly, when $\text{AIFSN}[i] = 2$, $T_{\text{AIFS}}[i]$ becomes identical to T_{DIFS} . The amendment [56] has also introduced the possibility of sending a train of consecutive frame by the concept of Transmission Opportunity (TXOP), but this feature is not exploited by the IEEE 802.11p amendment.

In the IEEE 802.11p standard the access mechanism is properly modified to work in the multi-channel WAVE environment, by implementing two separate EDCA functions, one for CCH and one for SCH, which handle different sets of queues for packets destined to be transmitted on different channel intervals, as shown by Fig. 2.13. Table 2.2 summarizes the most interesting parameters of the physical and MAC layers of IEEE 802.11, with the exception of the EDCA parameters, which are listed in Table 2.3. From Table 2.3 we observe that IEEE 802.11p uses the same CW_{\min} and CW_{\max} values of the original IEEE 802.11e specification [56], but slightly modified AIFSN values. While in standard WLAN the AC_VI and AC_VO correspond, respectively, to Video and Voice, in the case of IEEE 802.11p, AC_VI and AC_VO must be interpreted as ACs reserved for prioritized messages (e.g., critical safety warnings).

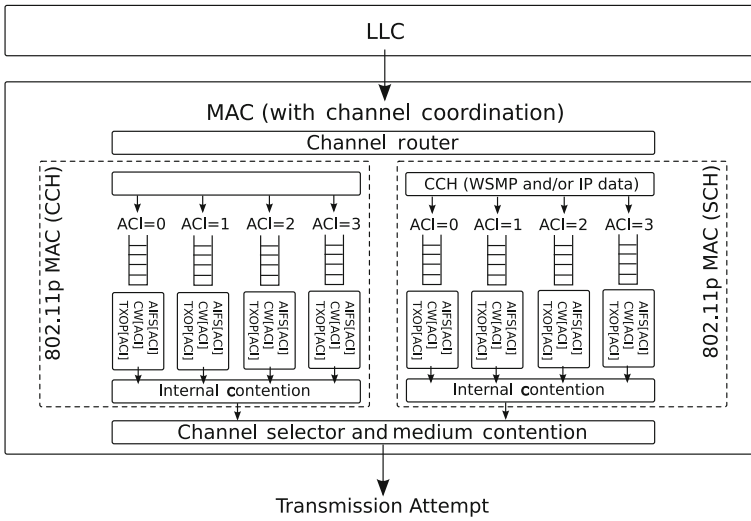

Fig. 2.13 Enhanced Distributed Channel Access mechanism defined by the IEEE 802.11p standard

Table 2.2 Main parameters of the IEEE 802.11p standard

Parameter	IEEE 802.11p
Carrier Frequency (GHz)	5.9
Bandwidth (MHz)	10
OFDM Guard Time (μ s)	1.6
CW_{min}	See Table 2.3
CW_{max}	1023
T_{SLOT} (μ s)	13
T_{SIFS} (μ s)	32
Data rates (Mbit/s)	3, 4.5, 6, 9, 12, 18, 24, 27

Table 2.3 EDCA parameters of the IEEE 802.11p standard

AC	CW_{min}	CW_{max}	AIFSN
AC_BK	15	1,023	9
AC_BE	15	1,023	6
AC_VI	7	15	3
AC_VO	3	7	2

2.5.4 ETSI ITS Protocol Stack

The main candidate protocol stack for ITS applications designed by ETSI is illustrated in Fig. 2.14. The physical and MAC layers have been standardized in 2009 by ETSI in the ITS-G5 protocol [55], which is largely based on IEEE 802.11p. The design goals and principles of ITS are the following:



Fig. 2.14 ETSI protocol stack

- quick media access (low latency broadcast/unicast communication);
- ad-hoc communication (no infrastructure requirements);
- allocated spectrum for ITS (communication reliability);
- 200-800m communication range;

The ITS-G5 protocol supports the Basic Transport Protocol (BTP) [57] and the GeoNetworking protocol for V2X communication [58], based on results from project GeoNet. GeoNetworking, in turn, uses both the BTP protocol and a own location-based addressing for all communications, including single-hop communication between ITSs. Finally, within the facilities, lay the two types of safety messages standardized by ETSI, referred as Cooperative Awareness messages (CAMs) [19] and Decentralized Environmental Notification Messages (DENMs) [20]. CAMs are heartbeat periodic messages, delivered to vehicles laying in the awareness range of the sender. DENMs are event-triggered messages delivered to vehicles laying in the relevant geographical area of the triggering event. Such a region of interest can span several hundred meters.

References

1. Willke, T., Tientrakool, P., Maxemchuk, N.: A survey of inter-vehicle communication protocols and their applications. *IEEE Commun. Surv. Tutor.* **11**(2), 3–20 (2009)
2. Lee, U., Magistretti, E., Gerla, M., Bellavista, P., Corradi, A.: Dissemination and harvesting of urban data using vehicular sensing platforms. *IEEE Trans. Veh. Technol.* **58**(2), 882–901 (2009)
3. Kato, S., Tsugawa, S., Tokuda, K., Matsui, T., Fujii, H.: Vehicle control algorithms for cooperative driving with automated vehicles and intervehicle communications. *IEEE Trans. Intell. Transp. Syst.* **3**(3), 155–161 (2002)
4. Broggi, A.: VisLab’s vehicles just reached siberia: driverless! now Kazakhstan and then China until Shanghai [ITS Events]. *IEEE Intell. Transp. Syst. Mag.* **2**(3), 43–44 (2010)
5. Machine to machine communications (M2M); use cases of automotive applications in M2M capable networks. ETSI TS 102 898 pp. 1–46 (2013)
6. Sepulcre, M., Mittag, J., Santi, P., Hartenstein, H., Gozalvez, J.: Congestion and awareness control in cooperative vehicular systems. *Proc. IEEE* **99**(7), 1260–1279 (2011)
7. Zhu, K., Niyato, D., Wang, P., Hossain, E., Kim, D.: Mobility and handoff management in vehicular networks: a survey. *Wirel. Commun. Mob. Comput.* **11**(4), 459–476 (2011)

8. Naumov, V., Gross, T.R.: Connectivity-aware routing (CAR) in vehicular ad-hoc networks. In: Proceedings of IEEE Conference on Computer Communication (INFOCOM), pp. 1919–1927. IEEE (2007)
9. Mecklenbrauker, C.F., Molisch, A.F., Karedal, J., Tufvesson, F., Paier, A., Bernado, L., Zemen, T., Klemp, O., Czink, N.: Vehicular channel characterization and its implications for wireless system design and performance. *Proc. IEEE* **99**(7), 1189–1212 (2011)
10. Vandenbergh, W., Moerman, I., Demeester, P.: On the feasibility of utilizing smartphones for vehicular ad hoc networking. In: ITS Telecommunications (ITST), 2011 11th International Conference on, pp. 246–251. IEEE (2011)
11. Fiore, M., Härril, J.: The networking shape of vehicular mobility. In: Proceedings of ACM International Symposium on Mobile ad hoc networking and computing (MobiHoc), pp. 261–272. ACM, New York, NY, USA (2008)
12. Andrews, J.G., Ghosh, A., Muhamed, R.: Fundamentals of WiMAX: understanding broadband wireless networking. Pearson Education (2007)
13. Institute of Electrical and Electronics Engineers: IEEE Std 802.16TM-2009. Part 16: Air Interface for Broadband Wireless Access Systems (2009)
14. Sesia, S., Toufik, I., Baker, M.: LTE: the UMTS long term evolution. Wiley Online Library (2009)
15. Dahlman, E., Parkvall, S., Skold, J., Beming, P.: 3G evolution: HSPA and LTE for mobile broadband. Elsevier, Amsterdam (2010)
16. Dahlman, E., Parkvall, S., Skold, J.: 4G: LTE/LTE-Advanced for Mobile Broadband: LTE/LTE-Advanced for Mobile Broadband. Academic Press, Waltham (2011)
17. Bleicher, A.: 4g gets real. *IEEE Spectr* **51**(1), 38–62 (2014)
18. Schoch, E., Kargl, F., Weber, M., Leinmuller, T.: Communication patterns in VANETs. *IEEE Commun. Mag.* **46**(11), 119–125 (2008)
19. Intelligent Transport Systems (ITS), vehicular communications, basic set of applications, part 2: Specification of cooperative awareness basic service. ETSI TS 102 637–2, pp. 1–18 (2011)
20. Intelligent Transport Systems (ITS), vehicular communications, basic set of applications, part 3: Specifications of decentralized environmental notification basic service. ETSI TS 102 637–3, pp. 1–46 (2010)
21. Zhang, T., Delgrossi, L.: Vehicle Safety Communications: Protocols, Security, and Privacy. Wiley Press, Hoboken (2012)
22. Inc., G.: Google latitude. <https://latitude.google.com/latitude/b/0>
23. Vodafone: Vodafone machine to machine. <http://m2m.vodafone.com/home/>
24. Thiagarajan, A., Ravindranath, L.S., LaCurts, K., Toledo, S., Eriksson, J., Madden, S., Balakrishnan, H.: Vtrack: Accurate, energy-aware traffic delay estimation using mobile phones. In: 7th ACM Conference on Embedded Networked Sensor Systems (SenSys). Berkeley, CA (2009)
25. Mobile, W.: Waze. <http://www.waze.com>
26. Guttman, A.: R-trees: a dynamic index structure for spatial searching. In: 14th ACM SIGMOD, vol. 14, pp. 47–57. ACM (1984)
27. Tran, D.A., Nguyen, T.: Hierarchical multidimensional search in peer-to-peer networks. *Comput. Commun.* **31**(2), 346–357 (2008)
28. Li, M., Lee, W., Sivasubramanian, A.: Dptree: A balanced tree based indexing framework for peer-to-peer systems. In: 14th IEEE ICNP (2006)
29. Namand, B., Sussman, A.: Dist: fully decentralized indexing for querying distributed multidimensional datasets. In: 20th IPDPS (2006)
30. Tanin, E., Harwood, A., Samet, H.: Using a distributed quadtree index in peer-to-peer networks. *VLDB J.* **16**(2), 165–178 (2007)
31. Liu, B., Lee, W.C., Lee, D.L.: Supporting complex multi-dimensional queries in p2p systems. In: 25th IEEE International Conference on Distributed Computing Systems (ICDCS '05) (2005)
32. Harwood, A., Tanin, E.: Hashing spatial content over peer-to-peer networks. In: Australasian Telecommunications, Networks and Applications Conference (ATNAC) (2003)

33. Tsao, S.L., Cheng, C.M.: Design and evaluation of a two-tier peer-to-peer traffic information system. *IEEE Commun. Mag.* **49**(5), 165–172 (2011)
34. Kovacevic, A., Liebau, N., Steinmetz, R.: Globase.com - a p2p overlay for fully retrievable location-based search. In: 7th IEEE International Conference on Peer-to-Peer Computing (2007)
35. Asaduzzaman, S., von Bochmann, G.: Geop2p: An adaptive peer-to-peer overlay for efficient search and update of spatial information. *CoRR abs/0903.3759* (2009)
36. Rybicki, J., Scheuermann, B., Kiess, W., Lochert, C., Fallahi, P., Mauve, M.: Challenge: peers on wheels—a road to new traffic information systems. In: Proceedings of the 13th Annual ACM International Conference on Mobile Computing and Networking (2007)
37. Rybicki, J., Scheuermann, B., Koegel, M., Mauve, M.: Peertis: a peer-to-peer traffic information system. In: Proceedings of the sixth ACM International Workshop on VehiculAr InterNETworking (2009)
38. Rybicki, J., Scheuermann, B., Mauve, M.: Peer-to-peer data structures for cooperative traffic information systems. *Pervasive Mob. Comput.* **8**(2), 194–209 (2012)
39. Kernighan, B., Lin, S.: An efficient heuristic procedure for partitioning graphs. *Bell Syst. Tech. J.* **49**(1), 291–308 (1970)
40. Intelligent transport systems (ITS); framework for public mobile networks in cooperative ITS (C-ITS). Technical report (2012)
41. Valerio, D., Ricciato, F., Belanovic, P., Zemen, T.: Umts on the road: broadcasting intelligent road safety information via mbms. In: Vehicular Technology Conference, 2008. VTC Spring 2008. IEEE, pp. 3026–3030. IEEE (2008)
42. Araniti, G., Campolo, C., Condoluci, M., Iera, A., Molinaro, A.: LTE for vehicular networking: a survey. *IEEE Commun. Mag.* **51**(5), 148–157 (2013)
43. Doppler, K., Rinne, M., Wijting, C., Ribeiro, C., Hugl, K.: Device-to-device communication as an underlay to lte-advanced networks. *IEEE Commun. Mag.* **47**(12), 42–49 (2009)
44. Gast, M.: 802.11 Wireless Networks: The Definitive Guide, Second edn. O’Reilly Media, Sebastopol (2005)
45. Insitute of Electrical and Electronics Engineers: IEEE Std 802.11TM-2007. Part 11: Wireless LAN Medium Access Control (MAC) and Physical Layer (PHY) specifications (2012)
46. IEEE: IEEE Standard for Information technology-Telecommunications and information exchange between systems-Local and metropolitan area networks-Specific requirements Part 11: Wireless LAN Medium Access Control (MAC) and Physical Layer (PHY) Specifications Amendment 6: Wireless Access in Vehicular Environments. *IEEE Std 802.11p-2010* (Amendment to IEEE Std 802.11-2007), pp. 1–51 (2010)
47. IEEE Standard for Information technology-Part 11: Wireless LAN Medium Access Control (MAC) and Physical Layer (PHY) specifications Amendment 5: Enhancements for Higher Throughput. *IEEE Std 802.11n-2009*, pp. 1–211 (2005)
48. Zhou, D., Huang, L., Lai, T.H.: On the scalability of IEEE 802.11 ad-hoc-mode timing synchronization function. *Wirel. Netw.* **14**, 479–499 (2008)
49. Wireless LAN Medium Access Control (MAC) and Physical Layer (PHY) Specifications Amendment 6:Medium Access Control (MAC) Security Enhancements. *IEEE Std 802.11i-2004*, pp. 1–190 (2004)
50. Wi-Fi Alliance: Wi-Fi CERTIFIED Wi-Fi Direct™ (2010). Disponibile: <http://www.wi-fi.org/register.php?file=wp/Wi-Fi/Direct/20101025/Industry.pdf>
51. Zimmermann, H.: OSI reference model-The ISO model of architecture for open systems interconnection. *IEEE Trans. Commun.* **28**(4), 425–432 (2002)
52. Uzcategui, R., Acosta-Marum, G.: WAVE: a tutorial. *IEEE Commun. Mag.* **47**(5), 126–133 (2009)
53. Insitute of Electrical and Electronics Engineers: IEEE 1609–2006. IEEE Trial-Use Standard for Wireless Access in Vehicular Environments (WAVE) (2006)
54. Jiang, D., Delgrossi, L.: IEEE 802.11 p: Towards an international standard for wireless access in vehicular environments. In: Vehicular Technology Conference, pp. 2036–2040. Marina Bay, Singapore (2008)

55. European profile standard for the physical and medium access control layer of Intelligent Transport Systems operating in the 5 ghz frequency band. ETSI ES 202 663 V1.1.0, pp. 1–27 (2010)
56. IEEE Standard for Information technology-Part 11: Wireless LAN Medium Access Control (MAC) and Physical Layer (PHY) specifications Amendment 8: Medium Access Control (MAC) Quality of Service Enhancements. IEEE Std 802.11e-2005, pp. 1–211 (2005)
57. Intelligent Transport Systems (ITS); vehicular communications; geonetworking; part 5: Transport protocols; sub-part 1: Basic transport protocol. ETSI TS 102 636-5-1, pp. 1–45 (2011)
58. Intelligent Transport Systems (ITS); vehicular communications; geonetworking. ETSI TS 102 636 V1 (all parts), pp. 1–44 (2011)



<http://www.springer.com/978-3-319-10667-0>

Advanced Technologies for Intelligent Transportation
Systems

Picone, M.; Busanelli, S.; Amoretti, M.; Zanichelli, F.; Ferrari,
G.

2015, XX, 238 p. 145 illus., 133 illus. in color., Hardcover
ISBN: 978-3-319-10667-0