

In which we explore many facets of the analysis of mechanical systems in the context of a simple one degree of freedom system. . .

2.1 Development

The basic building blocks for models of mechanisms are masses, springs, and dampers (sometimes called dashpots). Automobile shock absorbers and the piston in screen and storm door closers are common examples of dampers. The motion of a mass is governed by the forces applied to it. Figure 1.2 shows a fundamental one degree of freedom system. The mass can only move in the horizontal (y) direction.

The spring and the damper are in parallel. This is the normal configuration. Rotated 90° counterclockwise this could represent an automobile suspension unit—coil spring and shock absorber (damper) in parallel. I will discuss other configurations later. The diagram shows a mass motion forced by an external force. The mass can also be made to move if the support moves. I will address this possibility below.

2.1.1 An Aside About Friction

Friction is a dissipative mechanism. If you rub your hands together briskly, the friction between the two will make them warmer. This is an example of *sliding friction*, also known as *dry friction*. Sliding friction is common, but difficult to deal with analytically. The simplest useful model (which apparently dates back to Leonardo da Vinci) supposes that the force of friction is proportional to the normal force W between the two sliding objects. The proportionality constant μ is called the *coefficient of friction*. (da Vinci apparently believed it to be a universal constant equal to $1/4$.) The laws of dry friction:

Fig. 2.1 Force balance for sliding friction

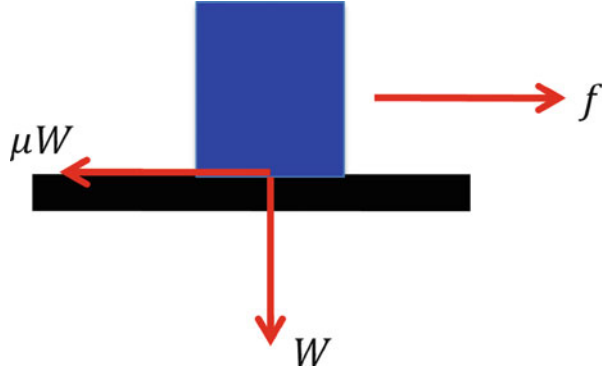

- The friction force is proportional to the applied load and independent of the contact area.
- The coefficient of sliding friction is independent of the speed of the motion.

are named for Amontons and Coulomb. Dry friction is often called *Coulomb friction*. Most models suppose that the coefficient of static friction μ_s is larger than the coefficient of sliding friction μ_d . The friction force always opposes the motion. Figure 2.1 shows a block and the forces involved.

The friction force will be less than μW if f is also less than μW . The friction force cannot induce motion; it can only impede motion. Figure 2.2 shows the friction force as a function of the applied force for this simple model. One can see the drop upon the commencement of motion and the subsequent constant friction force. The friction force adjusts to balance the applied force until it reaches its static limit $\mu_s W$, at which point the block starts to slide. The friction force drops because the coefficient of sliding friction is smaller than the coefficient of static friction, so the net force is positive and the block will accelerate.

It is relatively easy to measure two friction coefficients for this model using an inclined plane, as shown in Fig. 2.3. A simple static force balance gives the static friction coefficient

$$mg \sin \alpha = \mu mg \cos \alpha \rightarrow \mu_s = \tan \alpha \quad (2.1)$$

The angle α is often called the *friction angle*. The dynamic friction coefficient can be found by observing the fall of the block down the slope. I leave it to the exercises to show that

$$\mu_d = \mu_s - \frac{2s}{gT^2} \tan \alpha \quad (2.2)$$

where s denotes the distance slid in time T .

We cannot incorporate this model of friction into linear equations of motion. Dry friction does not depend on the motion linearly.

Fig. 2.2 Friction force as a function of applied force

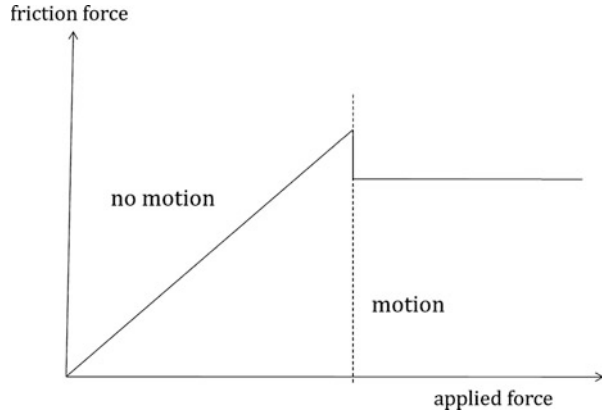
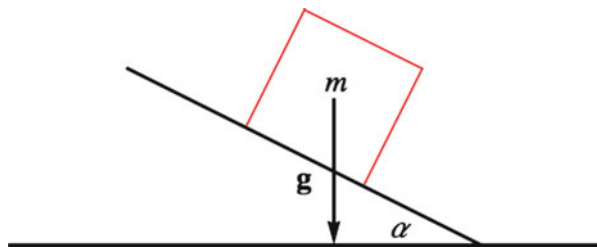

Fig. 2.3 An inclined plane for measuring friction coefficients



This does not mean that dry friction is unimportant. Dry friction is essential for stopping your car. Disc brakes work by forcing a pair of calipers to grip a disk rigidly attached to the wheel. The disk moves with respect to the calipers as long as the car is still moving, so the force on the disk depends on the coefficient of sliding friction. This friction force exerts a torque on the wheel, which causes it to slow down. The car slows because of the friction between the tire and the ground. Ultimately (as some tire commercials have pointed out) brakes don't stop your car: tires do. The patch of tire contacting the ground is stationary with respect to the ground (rolling without slipping). It can be approximated by a line contact for the present purposes. The appropriate coefficient of friction between the tire and the ground is the static coefficient. If you skid the appropriate friction coefficient becomes the coefficient of sliding friction, which is smaller, and your stopping power becomes less. Antilock brakes prevent this from happening, so you can stop more quickly.

The following discussion is a bit simplistic, but it will give a flavor of the design considerations involved in a braking system. The calipers are driven by a hydraulic cylinder. If the pad area is A , the pressure in the cylinder p and the appropriate coefficient of friction μ_1 , then the force on the disk is

$$f = 2\mu_1 Ap$$

and the torque on the wheel is then r_D times this, where r_D denotes the effective radius of the contact points. The force on the ground will be this torque divided by the wheel radius r_W . This force cannot exceed the static friction force between the road and the tire, which can vary greatly depending on the condition of the road (and the tire). We can write this in equation form as

$$f = 2\mu_1 Ap \leq \mu_2 N$$

where N denotes the normal force on the ground and μ_2 the coefficient of static friction between the tire and the road.

What happens if we interpose a layer of liquid between the block and the ground? The layer acts as a lubricant, and it provides no resistance to the initiation of motion. The resistance to motion parallel to the interface will be the integral of the shear stress in the liquid over the surface. (This leads to “aquaplaning” and accidents in the automotive application.) If the layer is thin, then the flow in the liquid will be laminar, and it can be approximated by plane Couette flow over most of the interface, the velocity varying linearly between the two surfaces. The stress is equal to the viscosity times the shear rate, which is constant for plane Couette flow. The shear rate is given by the speed divided by the thickness of the liquid layer. The resistance to motion parallel to the plane is thus proportional to the speed of motion and the contact area and inversely proportional to the thickness of the liquid layer. It is independent of the weight of the block. This is called *viscous friction*, friction proportional to the speed of motion. Any system where the resistance to motion is controlled by a liquid forced to pass through a narrow gap or opening where laminar flow is a good approximation will provide viscous friction to resist motion. Examples include lubricated bearings, shock absorbers, and screen door closers. The viscous friction approximation is convenient and a good approximation in many cases. It is amenable to linear analysis, which dry friction is not. I will use it more or less universally in this text; thus the model shown in Fig. 1.2 is an appropriate place to start our study of one degree of freedom problems.

2.1.2 The One Degree of Freedom Equation of Motion

We can write a single differential equation governing the motion of the mass shown in Fig. 2.1 considering it to be a free body acted on by the force shown and the spring and damper forces. Figure 2.4 shows a free body diagram of the mass.

The rate of change of momentum is equal to the sum of the forces, giving an equation of motion

$$m\ddot{y} = f - f_k - f_c$$

where y denotes the departure from equilibrium, positive to the right in the figure, and f_k and f_c denote the spring force and the damper force, respectively. If the block

Fig. 2.4 Free body diagram corresponding to Fig. 1.2

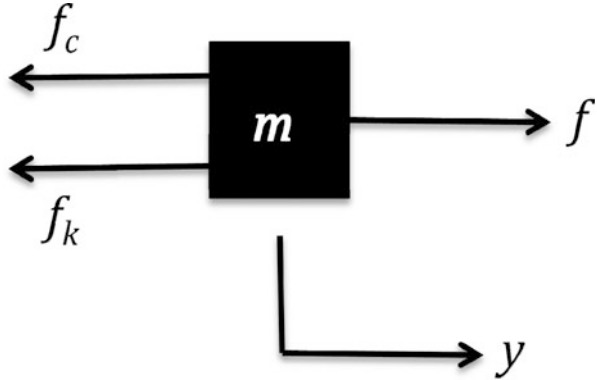

moves to the right, the spring will be stretched, and it will exert a force on the mass to the left. I will suppose that the force in a linear spring is proportional to the displacement from equilibrium. The force it exerts on the mass is to the left, and the force it exerts on the wall is to the right. The equation for the mass becomes

$$m\ddot{y} = f - k(y - y_0) - f_c$$

where y_0 denotes the position of the mass when the spring is not stretched or compressed. If $y > y_0$ the force on the block is to the left and if $y < y_0$ the force is to the right. It is common to choose the origin for y such that $y_0 = 0$. I will do so here. There is no loss of generality.

The damper works the same way, except that the force is proportional to the speed of the mass. Thus we can write

$$m\ddot{y} = f - ky - c\dot{y} \Rightarrow \ddot{y} + \frac{c}{m}\dot{y} + \frac{k}{m}y = \frac{f}{m} = a$$

The dimensions of k/m are $1/\text{time}^2$, and the dimensions of c/m are $1/\text{time}$. We can introduce a *natural frequency*, ω_n , and a *damping ratio*, ζ , the latter dimensionless¹

$$\frac{c}{m} = 2\zeta\omega_n, \quad \frac{k}{m} = \omega_n^2 \Leftrightarrow \omega_n^2 = \frac{k}{m}, \quad \zeta = \frac{c}{2m\omega_n} = \frac{c}{2\sqrt{km}} \quad (2.3)$$

and rewrite the one degree of freedom equation in standard form, where $a = f/m$ denotes the applied acceleration

$$\ddot{y} + 2\zeta\omega_n\dot{y} + \omega_n^2y = a \quad (2.4)$$

¹ This is the parameter I introduced in Chap. 1 (Eq. 1.12).

Equation (2.4) contains all that one needs to understand the dynamics of linear one degree of freedom systems. The equation governing the motion of a mass driven by a moving support can be put in this form, as I will show below, as can the equation governing the small angle motion of a pendulum. Equation (2.4) is inhomogeneous, that is, $y=0$ is not a solution. Specific problems are defined by adding initial conditions. A complete problem consists of a dynamical equation like Eq. (2.4) and a set of initial conditions. We'll have Eq. (2.4) and

$$y(0) = y_0, \quad \dot{y}(0) = v_0 \quad (2.5)$$

where y_0 and v_0 are constants, the position and speed of the mass at $t=0$.

Let us attack the general problem, Eq. (2.4) subject to the conditions given in Eq. (2.5), in successively more complicated situations, starting with the unforced system ($a=0$). Equation (2.4) becomes homogeneous. *Homogeneous equations with constant coefficients can always be solved in terms of exponential functions.* This is an important fact to remember. It applies to all systems of homogeneous differential equations with constant coefficients no matter the order of the individual equations or the number of equations. We learned in Chap. 1 that there is a connection between exponential and trigonometric functions. The solution to the simplest case, where there is no damping, can be found in terms of trigonometric functions alone.

2.2 Mathematical Analysis of the One Degree of Freedom Systems

2.2.1 Undamped Free Oscillations

Suppose $a=0=\zeta$. Equation (2.4) reduces to

$$\ddot{y} + \omega_n^2 y = 0$$

There is no external forcing and no damping. The system is homogeneous. Since there is no damping, we expect any nontrivial ($y \neq 0$) solution to persist forever.

As noted above a differential equation by itself does not define a problem, but a class of problems. Its solution, the so-called general solution, has as many undetermined constants as the order of the equation. Side conditions, as many as the order of the differential equation, are needed to determine these constants. Here we have one second-order differential equation. It needs two side conditions, and these are usually taken to be the initial conditions—the value of y and its first derivative at the beginning of the motion. (If both are zero, there is no motion.) I suppose the problem to start from $t=0$, so that Eq. (2.5) defines the initial conditions

$$y(0) = y_0, \quad \dot{y}(0) = v_0$$

The general solution of the differential equation can be written in terms of sines and cosines

$$y = A \cos(\omega_n t) + B \sin(\omega_n t) \quad (2.6)$$

Note that if we seek exponential solutions directly, $y = A \exp(st)$, the differential equation reduces to

$$s^2 A \exp(st) + \omega_n^2 A \exp(st) = 0 = (s^2 + \omega_n^2) A \exp(st)$$

so that we have a nontrivial solution if $s^2 = -\omega_n^2$ or $s = \pm j\omega_n$. We can use the connection between the exponential and the trigonometric functions given in Chap. 1 to convert the general exponential solution to the form of Eq. (2.6). This is only possible when s is purely imaginary. There is a similar transformation for complex values of s , which we will need when we have damping.

The solution given in Eq. (2.6) can also be expressed as

$$y = C \sin(\omega_n t + \phi) \quad (2.7)$$

where ϕ denotes a phase angle. You can verify either formula by direct substitution into the differential equation. To convert the form of Eq. (2.7) to that of Eq. (2.6), expand the sine using the usual multiple angle formulas

$$\begin{aligned} \sin(\alpha + \beta) &= \sin \alpha \cos \beta + \cos \alpha \sin \beta \\ \cos(\alpha + \beta) &= \cos \alpha \cos \beta - \sin \alpha \sin \beta \end{aligned}$$

to obtain

$$y = C \sin \phi \cos(\omega_n t) + C \cos \phi \sin(\omega_n t)$$

so that

$$A = C \sin \phi, \quad B = C \cos \phi \quad (2.8)$$

To convert from the form of Eq. (2.6) to that of Eq. (2.7), we can invert the process. We find directly from Eq. (2.8)

$$C^2 = A^2 + B^2, \quad \tan \phi = \frac{A}{B} \quad (2.9)$$

One has to be careful in calculating the phase. The inverse tangent is ambiguous. One can choose the appropriate quadrant by noting that

$$\sin \phi = \frac{A}{C}, \quad \cos \phi = \frac{B}{C}$$

The sine and cosine are both positive in the first quadrant ($0 < \phi < \pi/2$). The sine is positive and the cosine negative in the second quadrant ($\pi/2 < \phi < \pi$). The sine and cosine are both negative in the third quadrant ($\pi < \phi < 3\pi/2$). The sine is negative and the cosine positive in the fourth quadrant ($3\pi/2 < \phi < 2\pi$). The tangent is positive in the first and third quadrants and negative in the second and fourth quadrants.

The general solution becomes specific when the initial conditions are imposed, which is most easily done using the form in Eq. (2.6). We have

$$\begin{aligned} y(0) = A &\Rightarrow A = y_0 \\ \dot{y}(0) = \omega_n B &\Rightarrow B = \frac{v_0}{\omega_n} \end{aligned}$$

so that Eq. (2.10a)

$$y = y_0 \cos(\omega_n t) + \frac{v_0}{\omega_n} \sin(\omega_n t) \quad (2.10a)$$

gives the general solution for unforced, undamped motion of a one degree of freedom system in terms of its initial conditions. This solution can also be written in terms of the amplitude and phase as in Eq. (2.7). It represents a sinusoidal response at the natural frequency, ω_n . Sinusoidal motion with a single frequency is called *harmonic motion*. Harmonic motion is periodic; not all periodic motion is harmonic. The response of an unforced, undamped single degree of freedom system is harmonic, representable in terms of sines and cosines of $\omega_n t$. The initial conditions determine A and B , hence C , and the amplitude and phase

$$\begin{aligned} \text{amplitude} = C &= \sqrt{y_0^2 + \left(\frac{v_0}{\omega_n}\right)^2} \\ \sin \phi &= \frac{y_0}{\sqrt{y_0^2 + \left(\frac{v_0}{\omega_n}\right)^2}}, \quad \cos \phi = \frac{v_0/\omega_n}{\sqrt{y_0^2 + \left(\frac{v_0}{\omega_n}\right)^2}} \end{aligned} \quad (2.11)$$

Equation (2.10a) can also be written in terms of exponential functions using the trigonometric-exponential correspondences given in Chap. 1.

$$\begin{aligned} y &= x_0 \frac{1}{2} (e^{j\omega_n t} + e^{-j\omega_n t}) + \frac{v_0}{\omega_n} \frac{1}{2j} (e^{j\omega_n t} - e^{-j\omega_n t}) \\ &= \frac{1}{2} \left(x_0 - j \frac{v_0}{\omega_n} \right) e^{j\omega_n t} + \frac{1}{2} \left(x_0 + j \frac{v_0}{\omega_n} \right) e^{-j\omega_n t} \end{aligned} \quad (2.10b)$$

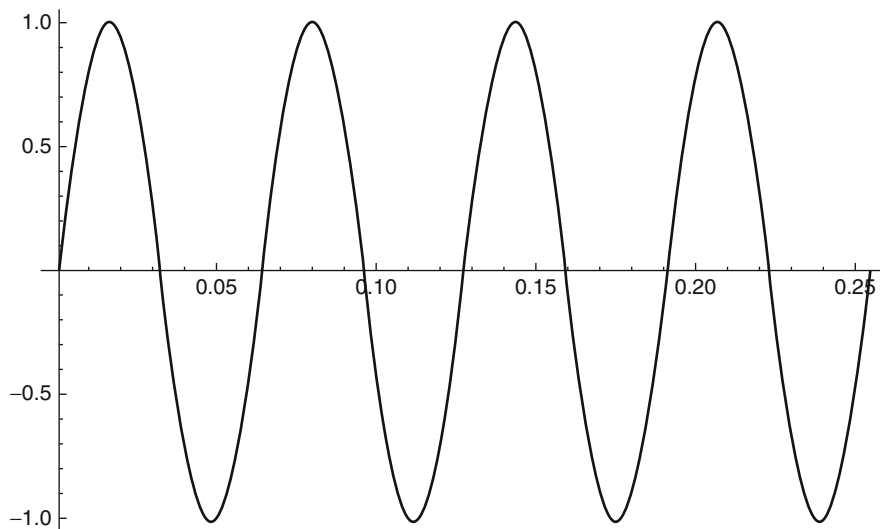

Fig. 2.5 Response of a one degree of freedom to an impulsive load (see text)

The two terms on the right are complex conjugates, so their sum is real, as it must be. We can solve differential equation in terms of complex exponentials and still arrive at physically meaningful real solutions. We'll see this shortly when we add dissipation to the homogeneous problem, but first let's look at a couple of examples.

Example 2.1 Response to an Impulse This simple one degree of freedom system seems a most artificial picture, but we can use it to examine the response of a simple system to an impulsive load. If we hit the system with a hammer some of its momentum will be transferred to the mass. In fact, if the hammer rebounds, then more than its momentum will be transferred. The hammer stops in a perfectly elastic collision, and all of the initial momentum of the hammer will be transferred to the mass. Suppose a 2 kg sledgehammer moving at 5 m/s collides elastically with a 10 kg mass attached to a 98,000 N/m spring. The momentum transferred will be $2 \times 5 = 10$ kg m/s. The velocity of the mass will jump "instantaneously" to 1 m/s, before the mass has a chance to move, so we can write our initial conditions as $v_0 = 1$ and $y_0 = 0$. The natural frequency of the system is $\sqrt{9,800} = 99$ rad/s ($=15.8$ Hz). The response of the system is then

$$y = \frac{1}{99} \sin(99t) \text{ m}$$

This is a harmonic response with an amplitude of about one cm. The frequency is a little below the threshold of human hearing.

Figure 2.5 shows a plot of the response over four periods. The amplitude is in cm and the horizontal scale in seconds. (In a real physical system there will be some damping, and the motion will decay. I will discuss this below.)

Fig. 2.6 Free body diagram of the bob of a simple pendulum

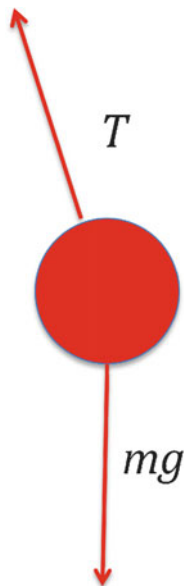

Example 2.2 The Simple Pendulum The simple pendulum is shown in Fig. 1.1. I denote the angle between the pendulum rod and the vertical by θ . This angle is zero when the pendulum hangs straight down and reckoned positive in the counter-clockwise direction ($\theta = \pi/2$ when the pendulum is extended horizontally to the right from its pivot point). The pendulum is confined to the plane. Let y denote the horizontal direction, positive to the right, and z denote the vertical, positive up following the convention I introduced in Chap. 1. Neglect the mass of the rod. The mass m , sometimes called the *bob*, is acted upon by two external forces: gravity in the $-z$ direction and a tension in the rod, directed parallel to the rod and in the upward direction, countering gravity. When the rod is vertical these two forces cancel and the pendulum is in static equilibrium. We can write two equations for the motion of the mass by drawing a free body diagram, Fig. 2.6.

We can resolve the forces in the y and z directions to give

$$\begin{aligned} m\ddot{y} &= -T \sin \theta \\ m\ddot{z} &= T \cos \theta - mg \end{aligned}$$

This is not the end of the story, because y and z are related. This is a one degree of freedom system; all the pendulum can do is swing back and forth along its circular arc. If we take the origin of the coordinate system to be at the base of the pendulum, where the rod attaches to the support, then we have

$$y^2 + z^2 = l^2$$

where l denotes the length of the rod. This expression can be parameterized in terms of the angle θ

$$y = l \sin \theta, \quad z = -l \cos \theta$$

The two differential equations become

$$\begin{aligned} ml(\ddot{\theta} \cos \theta - \dot{\theta}^2 \sin \theta) &= -T \sin \theta \\ ml(\ddot{\theta} \sin \theta + \dot{\theta}^2 \cos \theta) &= T \cos \theta - mg \end{aligned}$$

These can be combined into two equations, one of which determines θ as a function of time and the other the value of the tension as a function of time. Multiply the first by $\cos \theta$ and the second by $\sin \theta$ and add them to get the pendulum equation, Eq. (2.12a). Multiply the first by $-\sin \theta$ and the second by $\cos \theta$ and add them to get the tension equation, Eq. (2.12b).

We are primarily concerned with the first equation. It is unlikely that a simple pendulum will stretch or break the rod.

$$\ddot{\theta} + \frac{g}{l} \sin \theta = 0 \quad (2.12a)$$

$$T = ml\dot{\theta}^2 + mg \cos \theta \quad (2.12b)$$

The equation for θ is nonlinear, but if θ remains small during the motion, then the sine can be replaced by θ . This is a common approximation that can be justified by the Taylor series for the sine, which is

$$\sin \theta = \theta - \frac{1}{3!}\theta^3 + \frac{1}{5!}\theta^5 + \dots,$$

and if θ is small, θ^3 is much smaller than θ , and the higher order terms will be smaller still; thus $\sin \theta \approx \theta$ will be a good approximation for small θ . (I will discuss a formal process of linearization in Chap. 3 and then again in Chap. 6.) Applying this approximation gives a linear equation exactly parallel to the mass-spring system, a realization of Eq. (2.4) with $\zeta = 0$ and $\omega_n^2 = g/l$

$$\ddot{\theta} + \frac{g}{l}\theta = 0$$

We find by analogy that the (radian) frequency of a simple pendulum is given by $\sqrt{g/l}$. Its circular frequency is this divided by 2π , and so the period of a simple pendulum is given by $2\pi\sqrt{l/g}$. The length of a pendulum with a one second period will be 248.5 mm.

The period of a simple pendulum is independent of the mass of the bob, a fact that Galileo observed in 1581 while he was a medical student in Pisa.

Fig. 2.7 A torsional system:
moment-spring system

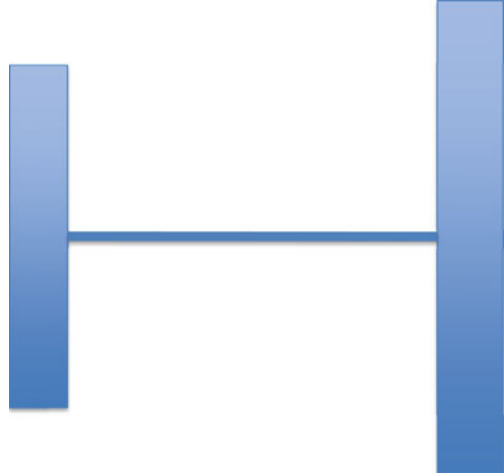

The mass-spring system and the pendulum are not the only systems that can be modeled by Eq. (2.4). The shafts in a gear train are under torsion. This is an elastic phenomenon, so the twist of a shaft away from equilibrium has an effective spring constant so long as the deformation remains in the elastic range. We can write the moment M associated with a given amount of twist as (see Crandall and Dahl 1959, or any equivalent strength of materials text)

$$M = \frac{GI_s}{l} \phi$$

where G denotes the shear modulus of the shaft material, I_s the polar moment of inertia of the shaft, l the length of the shaft, and ϕ the twist in radians. Consider the system shown in Fig. 2.7: two wheels connected by a shaft. Suppose the right-hand wheel to be fixed and consider the motion of the left-hand wheel. It may be subjected to an external torque, τ , and it is acted on by the twisting of the shaft. We can write its equation of motion, using the angle of twist as the dynamical variable, as

$$I_1 \ddot{\phi} = \tau - \frac{GI_s}{l} \phi$$

where I_1 denotes the polar moment of the left-hand wheel, typically much greater than that of the shaft. We can rearrange this and deduce the natural frequency of the system to be

$$I_1 \ddot{\phi} + \frac{GI_s}{l} \phi = \tau \Rightarrow \omega_n^2 = \frac{GI_s}{I_1 l}$$

Damping is usually pretty small in these systems, but one can certainly introduce damping, probably empirically. I will discuss measuring damping later in this chapter.

2.2.2 Damped Unforced Systems

The governing differential equation for unforced damped systems [from Eq. (2.4)] is

$$\ddot{y} + 2\zeta\omega_n\dot{y} + \omega_n^2y = 0$$

It is still homogeneous, but it no longer has purely trigonometric solutions. Because it is homogeneous with constant coefficients, it does have exponential solutions. Let's see what they are by choosing an arbitrary exponential and substituting that into the differential equation

$$y = Ye^{st} \Rightarrow \ddot{y} + 2\zeta\omega_n\dot{y} + \omega_n^2y = 0 = s^2Y + 2\zeta\omega_n sY + \omega_n^2Y$$

This is the first example of a technique we will use often. Y denotes an arbitrary (complex) constant. The constant parameter s is determined during the analysis. Y can be found from the initial conditions. This substitution converts the differential equation into an algebraic equation. Later we will generalize this method to convert systems of differential equations into systems of algebraic equations. (We will also find that the results look formally like the results of taking Laplace transform, but that connection must be deferred until Chap. 7.) We seek nontrivial solutions, solutions for which Y is not zero.

$$(s^2 + 2\zeta\omega_n s + \omega_n^2)Y = 0 \Rightarrow s^2 + 2\zeta\omega_n s + \omega_n^2 = 0 \quad (2.13)$$

If Y is not to be zero, the quadratic equation in parentheses must vanish. This is an example of a *characteristic equation*, which I will treat more formally later on. This determines two values of s , the roots of the quadratic equation. Denote these by s_1 and s_2 . The general solution is then

$$y = Y_1 e^{s_1 t} + Y_2 e^{s_2 t}, \quad (2.14)$$

and the values of Y_1 and Y_2 are determined by the initial conditions, just as they were for the trigonometric solution to the undamped problem. The initial conditions may be written

$$Y_1 + Y_2 = y_0, \quad s_1 Y_1 + s_2 Y_2 = v_0$$

from which

$$Y_1 = -\frac{s_2 y_0 - v_0}{s_1 - s_2}, \quad Y_2 = \frac{s_1 y_0 - v_0}{s_1 - s_2} \Rightarrow y = -\frac{s_2 y_0 - v_0}{s_1 - s_2} e^{s_1 t} + \frac{s_1 y_0 - v_0}{s_1 - s_2} e^{s_2 t} \quad (2.15)$$

Equation (2.15) is perfectly general. The nature of the solution depends on the values of the roots. We can apply the quadratic formula to obtain

Fig. 2.8 Roots of Eq. (2.13b) (given by Eq. 2.16) in the complex plane

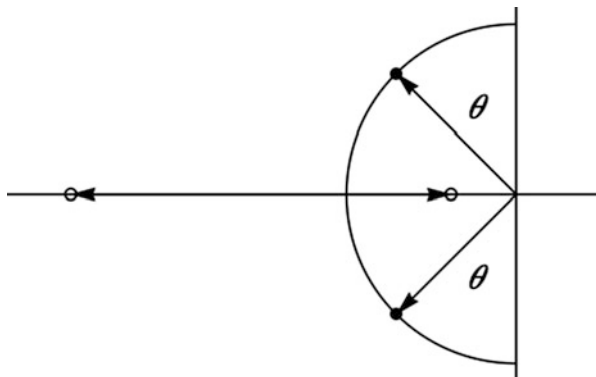

$$s_1 = -\zeta\omega_n + \omega_n\sqrt{\zeta^2 - 1}, \quad s_2 = -\zeta\omega_n - \omega_n\sqrt{\zeta^2 - 1} \quad (2.16)$$

The nature of the solution clearly depends on whether ζ is bigger or smaller than unity. The case $\zeta = 1$ is a special case. Engineering parameters are never determined to mathematical identity, and the difference in behavior between $\zeta = 0.99$ and 1.01 is generally indistinguishable. I will give an example below. The large ζ case is referred to as *overdamped*, and the small ζ case is referred to as *underdamped*. (The $\zeta = 1$ case is called *critically damped*, and we sometimes design for that.) The roots for the underdamped case are complex, having both real and imaginary parts. The roots are real (and negative) for the overdamped case. (The roots are purely imaginary for $\zeta = 0$, the undamped case we just looked at.)

We can visualize the behavior of the roots of Eq. (2.13b) as a function of ζ in the complex plane. Figure 2.8 shows the complex plane with the roots plotted for $\zeta = 1/2$ (underdamped, closed circles) and $\zeta = 3/2$ (overdamped, open circles). The roots lie on a circle of radius ω_n (unity in the figure) when the system is underdamped ($0 < \zeta < 1$). The roots are purely imaginary when $\zeta = 0$, the undamped case. When ζ reaches unity the two roots coincide and the system is critically damped. As ζ increases beyond unity, one root moves to the left and one to the right, as shown by the arrows, eventually approaching $-\infty$ and zero (from below). The angle θ shown in the figure is defined by the ratio of the real part to the imaginary part of the root and so is directly related to the damping ratio:

$$\tan \theta = \frac{\zeta}{\sqrt{1 - \zeta^2}} \Rightarrow \zeta = \sin \theta \quad (2.17)$$

The general solution can be rewritten in a more useful form in the (common) underdamped case by making use of the relations between exponential and trigonometric functions

$$y = \exp(-\zeta\omega_n t)(A \cos(\omega_d t) + B \sin(\omega_d t)) \quad (2.18a)$$

where $\omega_d = \sqrt{1 - \zeta^2} \omega_n$ is often called the *damped natural frequency*. This is the frequency you would measure. This form of the solution in terms of the initial conditions is

$$y = \exp(-\zeta \omega_n t) \left(y_0 \cos(\omega_d t) + \frac{v_0 - \zeta \omega_n y_0}{\omega_d} \sin(\omega_d t) \right) \quad (2.18b)$$

Equation (2.18b) is a much more useful form for underdamped systems than that given in Eq. (2.15).

We can learn about the behavior of the solutions by looking at how the impulse problem we have already studied changes when there is damping. I will make it simpler than before by setting $y_0 = 0$. I leave it to the reader to show that the solution to this problem [see Eq. (2.15)] for arbitrary ζ is

$$y = \frac{v_0}{2\omega_n \sqrt{\zeta^2 - 1}} \left(\exp\left(-\left(\omega_n \zeta + \sqrt{\zeta^2 - 1}\right)t\right) - \exp\left(-\left(\omega_n \zeta - \sqrt{\zeta^2 - 1}\right)t\right) \right) \quad (2.19)$$

If ζ is less than unity this can be written

$$\begin{aligned} y &= \frac{v_0}{2j\omega_n \sqrt{1 - \zeta^2}} \left(\exp\left(-\left(\zeta + j\sqrt{1 - \zeta^2}\right)\omega_n t\right) - \exp\left(-\left(\zeta - j\sqrt{1 - \zeta^2}\right)\omega_n t\right) \right) \\ &= \frac{e^{-\omega_n \zeta t}}{\omega_n \sqrt{1 - \zeta^2}} \frac{e^{(j\sqrt{1 - \zeta^2}\omega_n t)} - e^{(-j\sqrt{1 - \zeta^2}\omega_n t)}}{2j} \end{aligned} \quad (2.20)$$

The second quotient is recognizable as the sine, so we can write the underdamped solution as

$$y = \frac{\exp(-\zeta \omega_n t)}{\omega_n \sqrt{1 - \zeta^2}} \sin\left(\sqrt{1 - \zeta^2} \omega_n t\right) \quad (2.21)$$

Of course we could have found this result directly from Eqs. (2.18a) and (2.18b). If ζ is greater than unity the solution is as shown in Eq. (2.15)—both terms are real. Equation (2.21) gives the response of an underdamped system to a unit impulse.

Figure 2.9 shows the first two nominal periods ($4\pi/\omega_n$) of an underdamped case with $\zeta = 0.1$. One can see the effect of the damped frequency: the curve doesn't quite close because the actual period is longer than the ideal period. The damping also causes the solution to decay. There is significant decay even in the first quarter of the nominal period. The maximum value of the undamped response for the parameters in Fig. 2.9 is unity. The amplitude of the peak shown in Fig. 2.10 is 0.8626.

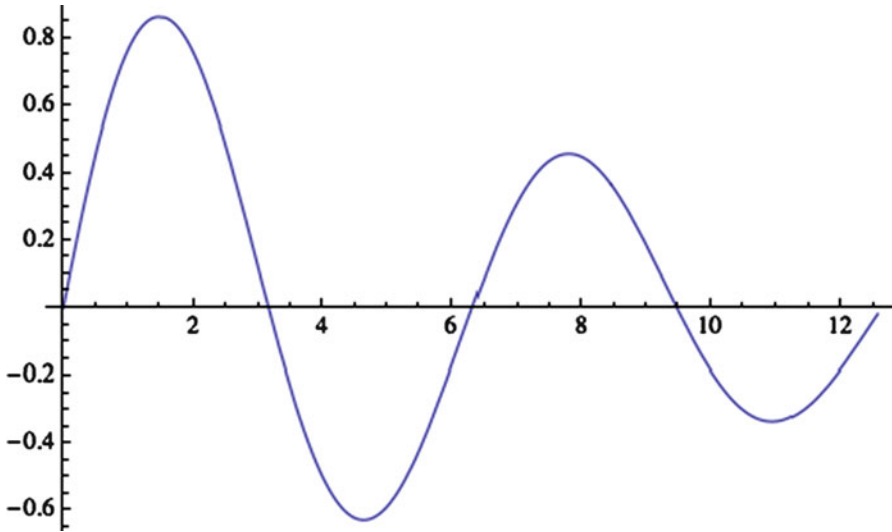

Fig. 2.9 The underdamped response to an impulsive load

Figure 2.10 shows the same time interval, but with a damping ratio of 10. The maximum amplitude is much reduced, but the decay time is much longer. This appears to be contradictory—more damping leads to a longer decay time. I leave it to you to think about why this is so. (Think about the implications of Fig. 2.8.) The most rapid decay is for a critically damped system, for which $\zeta = 1$.

I noted above that the difference between the response at a damping ratio of 0.99 and 1.01 was negligible. Figure 2.11 shows both responses to a unit impulse. The solid line is underdamped, and the dashed line is overdamped. There's little daylight between the two curves, although one can see the reduction in maximum response with increase in damping ratio. The difference is negligible (and probably unmeasurable) for engineering applications. Other approximations in modeling will overwhelm errors of this size.

We can summarize the behavior of an unforced one degree of freedom system as follows. If the system is in equilibrium and not disturbed, it will stay in equilibrium. If disturbed its behavior depends on the damping ratio ζ . If the damping ratio is zero there is no dissipation of energy and the system will oscillate at its natural frequency indefinitely—harmonic motion. If the damping ratio is not zero, the disturbed system will tend back to equilibrium, in an oscillatory fashion if the damping ratio is less than unity (underdamped) and without oscillations if the damping ratio is greater than unity (overdamped). The “frequency” of the oscillations in the underdamped case is less than the natural frequency. The decay time is a minimum for a damping ratio of unity (critically damped) and increases as the damping ratio increases from unity. Most of the systems with which we will be dealing will be underdamped. There will be some systems for which an undamped

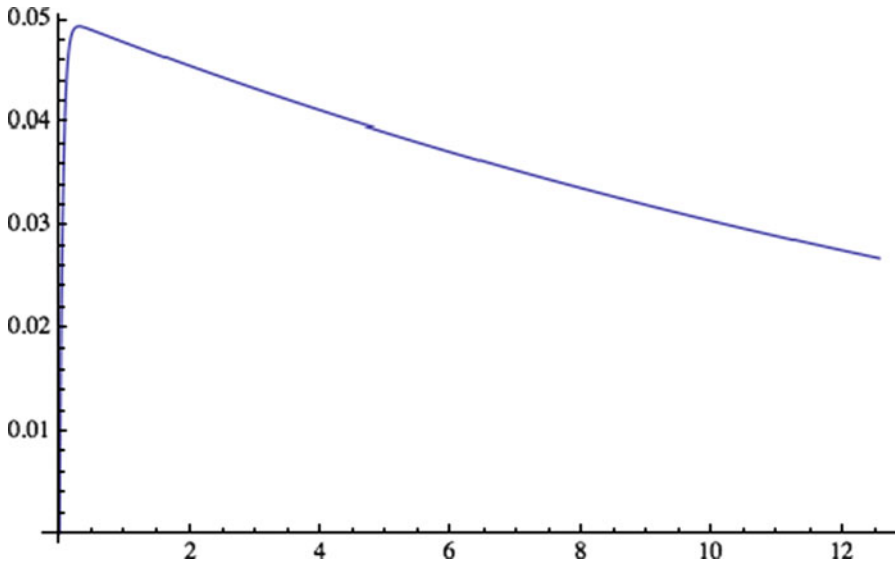

Fig. 2.10 The overdamped response to an impulsive load

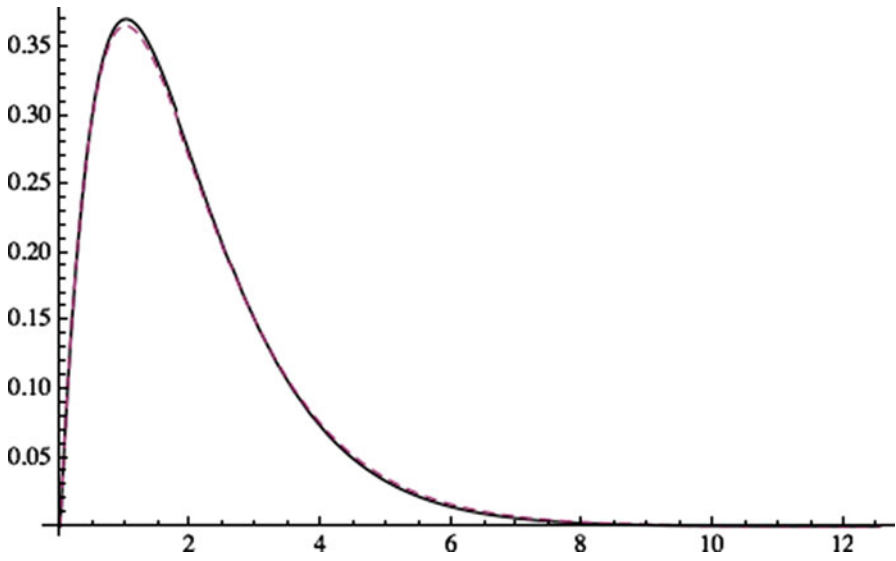

Fig. 2.11 The near critically damped response to a unit impulse

approximation makes sense, but all real systems have some damping. (Imagine the cacophony in the world were this not true!)

The e -folding time (the time it takes for the original value to decrease to $1/e$ times its initial value) for an underdamped system is $1/\zeta\omega_n$, so it will have disappeared for most practical purposes at about three times this number ($e^{-3} \approx 0.05$, 5 % of the initial amplitude). The 5 % time for the underdamped system just examined is about 30. For comparison, the critically damped version is down to 5 % in about 6 time units.

I can illustrate the techniques for dealing with forced system more clearly if I neglect damping to begin with—the various terms are simpler. But first let me say something about stability.

Equation (2.4) is our generalized one degree of freedom equation. The unforced system ($a=0$) that we have looked at so far can oscillate, or oscillate while its amplitude decays, or just decay to zero, as I just noted. We can say this another way. Set $a=0$ and multiply Eq. (2.4) by \dot{y} . We'll have

$$\dot{y}\ddot{y} + 2\zeta\omega_n\dot{y}^2 + \omega_n^2\dot{y}y = 0 \quad (2.22)$$

We can “integrate” Eq. (2.22) and rearrange it to get

$$\frac{1}{2} \frac{d}{dt} (\dot{y}^2 + \omega_n^2 y^2) = -2\zeta\omega_n \dot{y}^2 \quad (2.23)$$

The natural frequency is positive. The left-hand side of Eq. (2.23) is the derivative of the positive quantity $\dot{y}^2 + \omega_n^2 y^2$. The right-hand side is zero if $\zeta=0$, negative if $\zeta>0$, and positive if $\zeta<0$. If the right-hand side is negative, then the quantity $\dot{y}^2 + \omega_n^2 y^2$ must decrease in amplitude until it goes (asymptotically) to zero. This is an example of absolute global stability.

2.2.3 Forced Motion

Forced systems obey Eq. (2.4) with its associated initial conditions. The classical way to deal with this is to divide the solution into two parts, a homogeneous solution y_H and a particular solution y_P . The homogeneous solution is simply the general unforced solution that we have been examining. The particular solution is *any* solution that satisfies the inhomogeneous equation, without regard to the initial conditions. I will give a general formula for such a solution later in this section. The actual solution is the sum of the homogeneous and particular solutions.

Why do we need a homogeneous solution? Because the particular solution may not satisfy the initial conditions. Indeed, it specifically ignores them. The homogeneous solution exists to cancel any incorrect initial values of the particular solution. Let's see how this goes. Suppose we have found the particular solution. We already know how to find the homogeneous solution. We find the initial conditions for the

homogeneous solution by subtracting the initial values of the particular solution from the initial conditions specified in the problem:

$$y_H(0) = y_0 - y_P(0), \quad \dot{y}_H(0) = v_0 - \dot{y}_P(0),$$

and the analog of Eq. (2.15) will be

$$y = -\frac{s_2(y_0 - y_P(0)) - (v_0 - \dot{y}_P(0))}{s_1 - s_2} \exp(s_1 t) + \frac{s_1(y_0 - y_P(0)) - (v_0 - \dot{y}_P(0))}{s_1 - s_2} \exp(s_2 t)$$

If there is dissipation in the system, the homogeneous solution will decay away, and the long-term solution will be just the particular solution. In many situations we do not care about the initial conditions. In those cases we are said to *ignore the transients*, and then all we need to do is find the particular solution. This long-term solution is often referred to as the *steady solution*, even though it will be time dependent anytime the forcing a is time dependent. Deciding what to do about the transients (essentially the homogeneous solution) is a matter for engineering judgment. Sometimes it makes sense to ignore them, sometimes it does not. For now, let us assume that we need to take them into account and learn how to do this.

We know the homogeneous solution. It has two arbitrary constants, and we know that these can be determined from the initial condition once we have the particular solution. We need a particular solution. That is, we need to solve the inhomogeneous Eq. (2.4) (for now without damping). The solution clearly depends on the nature of the forcing acceleration a . If it is constant a_0 , then it is clear by inspection that

$$y_P = \frac{a_0}{\omega_n^2}$$

If a is some power of time, then we can construct a polynomial for y_P of the same degree as the power. Let me illustrate this for t^3 .

$$\ddot{y}_P + 2\zeta\omega_n\dot{y}_P + \omega_n^2 y_P - t^3 = 0$$

Let

$$y_P = a_0 + a_1 t + a_2 t^2 + a_3 t^3$$

Substituting this into the differential equation leads to a polynomial of degree three that has to vanish for all time. This will only be true if each power of t vanishes separately, which gives four equations to determine the four coefficients in the expression for y_P . It is easy enough to show that these four equations are

$$\begin{aligned}(a_3\omega_n^2 - 1)t^3 &= 0 \\ \omega_n(6\zeta a_3 + \omega_n a_2)t^2 &= 0 \\ (6a_3 + \omega_n(4\zeta a_2 + \omega_n a_1))t &= 0 \\ (2a_2 + \omega_n(2\zeta a_1 + \omega_n a_0))t^0 &= 0\end{aligned}$$

They can be solved successively for all four coefficients. I leave the details to the reader. If I can do it for any power, then I can do it for any function with a convergent Taylor series. Of course, this is of purely academic interest.

If a is a harmonic function, which is a much more important case, then y_P will also be harmonic at the forcing frequency, with a phase determined by the natural frequency and damping ratio

$$y_P = A \sin(\omega_f t + \phi)$$

Let's look at this case and use it to explore the combination of particular and homogeneous solutions.

Example 2.3 Response of an Undamped System to Harmonic Forcing Let $a = A_f \sin(\omega_f t)$. I can choose zero phase without loss of generality. It is important to remember that this forcing frequency is not the same as the natural frequency. (We'll see what happens when it is shortly.) The differential equation is

$$\ddot{y}_P + 2\zeta\omega_n\dot{y}_P + \omega_n^2 y_P - A_f \sin(\omega_f t) = 0$$

We see that there are two frequencies in the problem, the natural frequency and the forcing frequency. The particular solution depends on both. It oscillates at the forcing frequency, but its amplitude depends on both frequencies. We'll see shortly that the nature of the solution depends on the forcing frequency through its ratio to the natural frequency. I will denote this by $r = \omega_f/\omega_n$.

I will neglect damping for now, making the equation simpler

$$\ddot{y}_P + \omega_n^2 y_P - A_f \sin(\omega_f t) = 0$$

We are just looking for the particular solution right now, so we don't care about the initial conditions. Since the second derivative of the sine is proportional to the sine, we can find a particular solution by supposing it to be proportional to $\sin(\omega_f t)$: $y_P = Y_P \sin(\omega_f t)$. The differential equation becomes

$$(-\omega_f^2 Y_P + \omega_n^2 Y_P - A_f) \sin(\omega_f t) = 0 \Rightarrow Y_P = \frac{A_f}{\omega_n^2 - \omega_f^2} = \frac{1}{\omega_n^2(1 - r^2)} A_f$$

We see that the response is in phase with the excitation for low forcing frequencies (compared to the natural frequency, small r) and π radians out of phase for high forcing frequencies (large r). We see that the amplitude of the

response is formally infinite if the forcing frequency equals the natural frequency ($r = 1$). This state of affairs is called *resonance*. Since the point of this example is how to connect the particular and homogeneous solutions, I will ignore the possibility of resonance for now and write

$$y_P = A_f \frac{\sin(\omega_f t)}{\omega_n^2 - \omega_f^2}, \quad \dot{y}_P = A_f \frac{\omega_f \cos(\omega_f t)}{\omega_n^2 - \omega_f^2} \Rightarrow y_P(0) = 0, \quad \dot{y}_P(0) = \frac{A_f \omega_f}{\omega_n^2 - \omega_f^2}$$

We know the homogeneous solution to the undamped system, so we have

$$y_H = A \cos(\omega_n t) + B \sin(\omega_n t) \Rightarrow y_H(0) = A, \quad \dot{y}_H(0) = \omega_n B$$

If $y = y_0$ and $\dot{y} = v_0$ at $t = 0$, then the initial conditions that determine A and B are

$$y(0) = A = y_0, \quad \dot{y}(0) = \omega_n B + \frac{A_f \omega_f}{\omega_n^2 - \omega_f^2} = v_0$$

from which

$$A = y_0, \quad B = \frac{1}{\omega_n} \left(v_0 - \frac{A_f \omega_f}{\omega_n^2 - \omega_f^2} \right) = \frac{v_0}{\omega_n} - \frac{r}{\omega_n^2(1 - r^2)} A_f$$

So we have the homogeneous solution

$$y_H = y_0 \cos(\omega_n t) + \left(\frac{v_0}{\omega_n} - \frac{r}{\omega_n^2(1 - r^2)} A_f \right) \sin(\omega_n t),$$

and the complete solution is the sum of the homogeneous and particular solutions

$$y = y_0 \cos(\omega_n t) + \left(\frac{v_0}{\omega_n} - \frac{r}{\omega_n^2(1 - r^2)} A_f \right) \sin(\omega_n t) + \frac{1}{\omega_n^2(1 - r^2)} A_f \sin(\omega_f t)$$

There are two harmonic terms, one at the forcing frequency and one at the natural frequency. The solution itself is not harmonic because it has more than one frequency.

2.2.4 The Particular Solution for a Harmonically Forced Damped System

The process is more complicated when the system is damped. Let us consider the particular solution to a harmonic forcing in the presence of damping. The homogeneous solution can be added at the end following the paradigm reviewed in Ex. 2.3. I can tackle this problem using trigonometric functions or complex exponentials.

This is a matter of taste, and I will explore both methods here. I suppose that I have the same forcing as the previous example. The particular solution must satisfy

$$\ddot{y}_P + 2\zeta\omega_n\dot{y}_P + \omega_n^2 y_P - A_f \sin(\omega_f t) = 0$$

2.2.4.1 The Trigonometric Approach

The solution will be harmonic at the forcing frequency, but it cannot be proportional to the sine alone because the first derivative introduces a cosine term. Therefore we must write

$$y_P = A_P \cos(\omega_f t) + B_P \sin(\omega_f t) \quad (2.24)$$

When this is substituted into the differential equation, there will be two terms, one proportional to the sine and one proportional to the cosine. The two terms must both vanish independently for the equation to be satisfied for all time. It is easy to verify that the coefficients of the cosine and sine in Eq. (2.24) are

$$2B_P\zeta\omega_f\omega_n + (\omega_n^2 - \omega_f^2)A_P = 0 = (\omega_n^2 - \omega_f^2)B_P - 2A_P\zeta\omega_f\omega_n - A_f$$

This is a pair of inhomogeneous algebraic equations that can be solved for A and B . That result is

$$A_P = -\frac{2\zeta\omega_f\omega_n A_f}{(\omega_n^2 - \omega_f^2)^2 + (2\zeta\omega_f\omega_n)^2}, \quad B_P = \frac{(\omega_n^2 - \omega_f^2)A_f}{(\omega_n^2 - \omega_f^2)^2 + (2\zeta\omega_f\omega_n)^2}$$

or

$$A_P = -\frac{2\zeta r A_f}{\omega_n^2 \left((1 - r^2)^2 + (2\zeta r)^2 \right)}, \quad B_P = \frac{(1 - r^2)A_f}{\omega_n^2 \left((1 - r^2)^2 + (2\zeta r)^2 \right)} \quad (2.25a)$$

so that

$$y_P = -\frac{2\zeta r A_f}{\omega_n^2 \left((1 - r^2)^2 + (2\zeta r)^2 \right)} \cos(\omega_f t) + \frac{(1 - r^2)A_f}{\omega_n^2 \left((1 - r^2)^2 + (2\zeta r)^2 \right)} \sin(\omega_f t) \quad (2.25b)$$

The amplitude of this response, Y_P , is given by $\sqrt{A_P^2 + B_P^2}$.

$$Y_P = \frac{A_f}{\omega_n^2 \sqrt{(1 - r^2)^2 + (2\zeta r)^2}} \quad (2.25c)$$

and the phase by

$$\tan \phi = -\frac{2\zeta r}{(1 - r^2)} \quad (2.25d)$$

The force applied to the system is m times A_f . The natural frequency is the square of the ratio of k to m , so that $A_f/\omega_n^2 = F/k$, which is the amount that the spring would be compressed if F were constant, it provides a reference displacement; y_k/F is the dimensionless response of the system. Equation (2.25c) tells us the amplitude of the response of a damped single degree of freedom system to harmonic excitation. We can plot the response as a function of r for various values of the damping ratio. Figure 2.12 shows the scaled magnitude, $y' = y_k/F$, of the response for ζ ranging from 0.1 to 1.0 at intervals of 0.1. The dimensionless response is unity at zero excitation frequency and goes to zero as increases without bound. As we can see from Eq. (2.25c), the maximum amplitude is at the nominal resonance—the forcing frequency equal to the natural frequency ($r = 1$). We can use this value to find the damping ratio from the amplitude plot

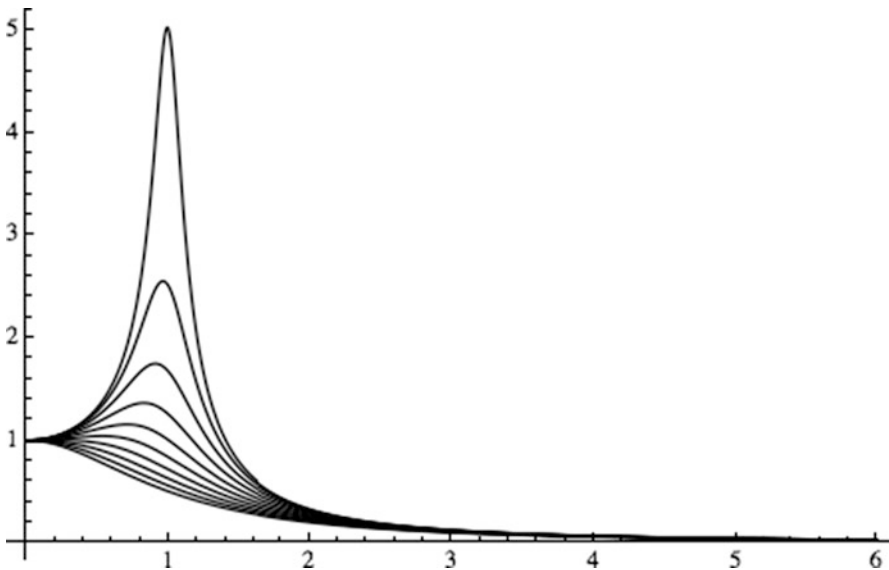

Fig. 2.12 The dimensionless amplitude of the response to a damped system to harmonic forcing. The vertical axis is relative displacement and the horizontal axis the ratio of forcing frequency to natural frequency

$$\zeta = \frac{1}{2y'_{\max}} \quad (2.25e)$$

I'll discuss an alternate way of determining ζ when the system is underdamped later.

For high forcing frequencies (compared to the natural frequency, large r) the amplitude is small (asymptotically zero) and basically independent of the damping ratio. Physically the forcing is changing so rapidly that the inertia of the system gives it no time to respond. The response given by Eq. (2.15) is valid once the transients have decayed. If the transients are important, then a homogeneous solution—some realization of Eq. (2.9)—must be added to form a complete solution.

2.2.4.2 The Complex Variable Approach

We learned in Chap. 1 that the complex exponential is equivalent to the trigonometric functions. We can use this as an alternate way of finding the particular solution. We can rewrite the differential equation, replacing the sine by its complex equivalent

$$\ddot{y}_P + 2\zeta\omega_n\dot{y}_P + \omega_n^2 y_P = A_f \frac{1}{2j} (e^{j\omega_f t} - e^{-j\omega_f t})$$

The two terms on the right-hand side are complex conjugates. The equation is linear, so the particular solution will have two parts, one forced by the first term on the right-hand side and one by its complex conjugate. These solutions will be complex conjugates of each other. We can find the solution by solving one of the equations and adding the complex conjugate of that solution to form the full solution. Symbolically, we can find y_{P1} as the solution to

$$\ddot{y}_{P1} + 2\zeta\omega_n\dot{y}_{P1} + \omega_n^2 y_{P1} = A_f \frac{e^{j\omega_f t}}{2j}$$

and write

$$y_P = y_{P1} + y_{P1}^*$$

where the asterisk denotes complex conjugate. Now the sum of a function and its complex conjugate is twice the real part of the function

$$y_P = 2\text{Re}(y_{P1})$$

I can incorporate the factor of two by multiplying the governing equation by 2 and define $y_Q = 2 y_P$ to give

$$\ddot{y}_Q + 2\zeta\omega_n\dot{y}_Q + \omega_n^2 y_Q = -A_f j e^{j\omega_f t}$$

We solve this equation for y_Q and take its real part to give y_P . That is a relatively easy task. This is an important point, however, so I will spend a bit of time going through the details.

First multiply the original equation by 2 and move the j on the right-hand side to the numerator (multiply top and bottom by j)

$$2\ddot{y}_P + 4\zeta\omega_n\dot{y}_P + 2\omega_n^2y_P = -jA_f(e^{j\omega_f t} - e^{-j\omega_f t})$$

Replace y_P by its expression in terms of y_{P1} and its conjugate

$$2(\ddot{y}_{P1} + \ddot{y}_{P1}^*) + 4\zeta\omega_n(\dot{y}_{P1} + \dot{y}_{P1}^*) + 2\omega_n^2(y_{P1} + y_{P1}^*) = -jA_f(e^{j\omega_f t} - e^{-j\omega_f t})$$

Define y_Q as twice y_P , and write this as two equivalent equations

$$\begin{aligned}\ddot{y}_Q + 2\zeta\omega_n\dot{y}_Q + \omega_n^2y_Q &= -jA_f e^{j\omega_f t} \\ \ddot{y}_Q^* + 2\zeta\omega_n\dot{y}_Q^* + \omega_n^2y_Q^* &= jA_f e^{-j\omega_f t}\end{aligned}$$

It is clear that the particular solution to either will be proportional to the exponential, and we find directly that the complex amplitude of the solution is

$$Y_Q = -\frac{jA_f}{(\omega_n^2 - \omega_f^2 + 2j\zeta\omega_n\omega_f)} = -\frac{jA_f(1 - r^2 - 2j\zeta r)}{\omega_n^2((1 - r^2)^2 + (2\zeta r)^2)}$$

Parts of this formula should look familiar.

The important thing to note is that one does not take the real part of Y_Q . One takes the real part of the actual solution, y_Q , which is given by

$$y_Q = Y_Q \exp(j\omega_f t) = -\frac{jA_f(1 - r^2 - 2j\zeta r)}{\omega_n^2((1 - r^2)^2 + (2\zeta r)^2)} \exp(j\omega_f t)$$

Expand the exponential and take the real part

$$\begin{aligned}y_P &= -\operatorname{Re} \left[\frac{jA_f(1 - r^2 - 2j\zeta r)}{\omega_n^2((1 - r^2)^2 + (2\zeta r)^2)} (\cos(\omega_f t) + j \sin(\omega_f t)) \right] \\ &= \frac{-2\zeta r \cos(\omega_f t) + (1 - r^2) \sin(\omega_f t)}{\omega_n^2((1 - r^2)^2 + (2\zeta r)^2)}\end{aligned}$$

which one can see is identical to Eq. (2.23). The two methods are equivalent, as they must be. The choice of method is a matter of personal taste.

2.3 Special Topics

2.3.1 Natural Frequencies Using Energy

We found natural frequencies for undamped one degree of freedom systems by writing and solving the differential equations. This is how we will find natural frequencies for more complicated systems. However, it is interesting to note that we can find natural frequencies for one degree of freedom systems by consideration of energy alone. I want to address energy here because it is fundamental for the derivation of the equations of motion for the more complicated systems that we will see starting in Chap. 3.

An undamped, unforced system once set in motion will stay in motion perpetually (see Fig. 1.2 with the damper removed). Its energy is conserved: the sum of the maximum kinetic energy and the minimum potential energy must equal the sum of the minimum kinetic energy and the maximum potential energy

$$T_{\max} + V_{\min} = T_{\min} + V_{\max}$$

The minimum kinetic energy is zero, because the kinetic energy is proportional to the square of the speed, which is zero twice during any simple oscillation, so we have

$$T_{\max} = V_{\max} - V_{\min} \quad (2.26)$$

In one degree of freedom systems for which there is a restoring force (so that it will oscillate), the potential is an even function of the variable, which I will denote by y

$$V = V_0 + V_2 y^2 + \dots$$

Thus

$$T_{\max} = V_{\max} - V_{\min} = V_2 y^2 + \dots$$

where the constant term cancels. The idea of natural frequency makes sense only for small motions or for systems that are linear in their nature. In either case the $+\dots$ terms are negligible, so that the maximum kinetic energy will be proportional to the square of the magnitude of the displacement. In most cases V_{\min} will be zero. When it is not, it will be independent of the motion and will cancel from Eq. (2.26). This allows us to find the natural frequency. If we have harmonic motion, which we must have if we are to speak of natural frequencies, then we can write that $\ddot{y} = -\omega_n^2 y$. The left-hand side of Eq. (2.26) can be written in terms of the amplitude of the oscillation Y and the natural frequency.

$$T_{\max} \propto \omega_n^2 Y^2$$

The right-hand side can also be written in terms of the amplitude

$$V_{\max} - V_{\min} = V_2 y^2 + \dots \approx V_2 Y^2$$

The proportionality constant for the kinetic energy and V_2 are different for each problem, but their ratio determines the square of the natural frequency. Let me go through some examples, starting with the simple mass-spring system.

Two points in this motion are special. When the (effective) spring is unstretched (the equilibrium position for a stationary mass) the mass is moving at its maximum speed. When the mass is stationary, the spring is at its maximum tension (compression). In the former case all the energy of the system is kinetic, in the latter, potential. We can write these two energies as

$$T = \frac{1}{2} m \dot{y}^2, \quad V = \frac{1}{2} k y^2$$

where we denote the kinetic energy by T and the potential energy by V . The potential energy supposes that I have chosen the origin for y such that the potential energy is zero when the spring is unstretched. We have already established that the motion is harmonic, so we can write (using the amplitude and phase notation for convenience)

$$y = Y \sin(\omega_n t + \varphi), \quad \dot{y} = Y \omega_n \cos(\omega_n t + \varphi)$$

The maximum displacement occurs when the sine is unity and the maximum speed when the cosine is unity. We can then find the maximum kinetic and potential energies and equate these.

$$T_{\max} = \frac{1}{2} m Y^2 \omega_n^2 = V_{\max} = \frac{1}{2} k Y^2 \Rightarrow \omega_n^2 = \frac{k}{m}$$

The square of the natural frequency here is what we expect it to be, the ratio of the energy storage coefficient to the inertia coefficient.

The restoring force for the mass-spring example is the spring force. The restoring force for the pendulum is gravity. What happens when both gravity and a spring can act? It depends on the circumstances, but let's look now at the application of the energy argument for the mass-spring system in a vertical position. The potential energy here has both a spring and gravity component. Figure 2.13 shows the system.

This is a one degree of freedom system with motion only in the z direction. Denote the location of the mass where the spring is relaxed by z_0 , and the equilibrium position of the spring, where the spring force just balances gravity, by z_1 . A simple force balance— $mg = k(z_0 - z_1)$ —shows that

Fig. 2.13 A vertical mass-spring system

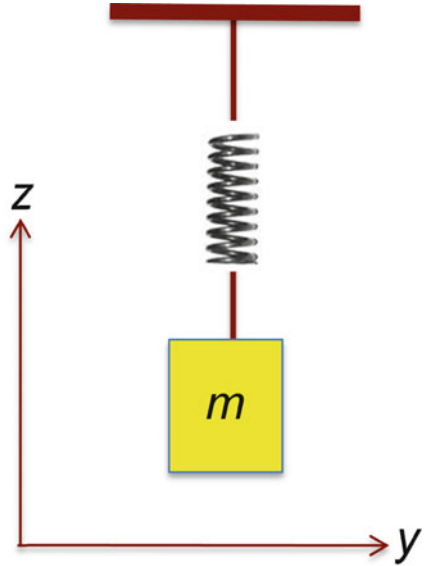

$$z_1 = z_0 - \frac{mg}{k}$$

We can write the energies of the system

$$T = \frac{1}{2}m\dot{z}^2, \quad V = mgz + \frac{1}{2}(z - z_0)^2$$

We expect the system to oscillate harmonically about its equilibrium position. We can write

$$\begin{aligned} z &= z_1 + Z \sin(\omega_n t + \phi) \\ \dot{z} &= \omega_n Z \cos(\omega_n t + \phi) \end{aligned}$$

where Z denotes the amplitude of the oscillation. The energies are

$$T = \frac{1}{2}m\omega_n^2 Z^2 \cos^2(\omega_n t + \phi)$$

$$V = mg(z_1 + Z \sin(\omega_n t + \phi)) + \frac{1}{2}(z_1 + Z \sin(\omega_n t + \phi) - z_0)^2$$

Substituting for z_1 and expanding the potential energy gives

$$V = \frac{1}{2}kZ^2 \sin^2(\omega_n t + \phi) + mgz_0 - \frac{m^2 g^2}{2k}$$

We can use Eq. (2.26) to get the natural frequency.

$$T_{\max} = V_{\max} - V_{\min}$$

The two minima for the horizontal mass-spring system were both zero. In the present case we have

$$\frac{1}{2}m\omega_n^2 Z^2 = \frac{1}{2}kZ^2 + mgz_0 - \frac{m^2 g^2}{2k} - \left(mgz_0 - \frac{m^2 g^2}{2k} \right)$$

The constant terms cancel and we reproduce the previous formula.

The following example shows the power of the energy method.

Example 2.4 Find the Frequency of Sloshing in a U-Tube Filled with an Inviscid Liquid I first ran across this example in Den Hartog (1956). The approach below is different from his, but the result is, of course, the same.

Figure 2.14 shows a U-tube manometer. I assume the fluid to be inviscid, so there is no dissipation in the system. I also assume the liquid to be incompressible. We would like to find the natural frequency of this system as the liquid sloshes up and down. Denote the total length of the liquid by l , its density by ρ , and the cross-sectional area of the tube by A . The mass of the fluid is then $m = \rho Al$. The dynamical variable is h as shown in the figure. $h = 0$ corresponds to equilibrium. The kinetic energy is straightforward if we assume that the fluid moves as a unit:

$$T = \frac{1}{2}mv^2 = \frac{1}{2}\rho Al\dot{h}^2$$

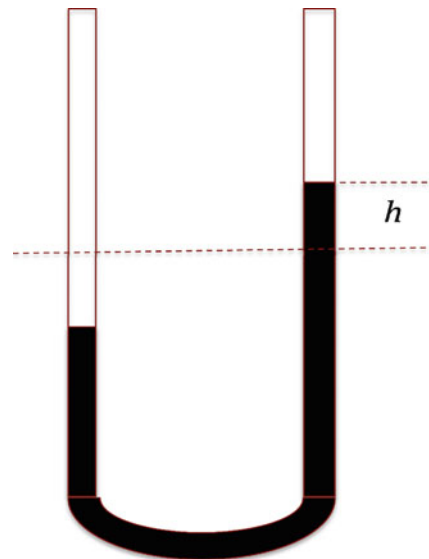

Fig. 2.14 A U-tube manometer. h denotes the distance the liquid has moved up and down from the equilibrium position, shown by the long dashed line

To get from the equilibrium configuration to the configuration shown in the figure, we moved a mass ρAh from the vacant spot below the dashed line on the left to the filled spot above the line. The center of mass moved up a distance h , so the change in potential energy was

$$V = \rho Ahg$$

(I will take the $h=0$ equilibrium to define the reference state of the potential energy.)

Supposing the system to be harmonic and equating the two maxima gives

$$\omega_n^2 = \frac{\rho Ag}{\frac{1}{2}\rho Al} = 2\frac{g}{l}$$

We can find the equation of motion from this, because in a nondissipative one degree of freedom system, the only parameter is the natural frequency. We'll have

$$\ddot{h} + 2\frac{g}{l}h = 0$$

2.3.2 A General Particular Solution to Eq. (2.4)

We can write an integral expression that purports to solve Eq. (2.4)

$$y = \int_0^t \phi(t-\tau)a(\tau)d\tau \quad (2.27)$$

Our task is to find the function ϕ such that Eq. (2.27) solves Eq. (2.4), which we can do by substituting Eq. (2.27) into Eq. (2.4). To do this we need to recall how to differentiate a definite integral. The derivative is equal to the integral of the derivative of the integrand, plus the derivative of the upper limit times the integrand evaluated at the upper limit, minus the derivative of the lower limit times the integrand evaluated at the lower limit. For y given by Eq. (2.26), we have

$$\dot{y} = \int_0^t \dot{\phi}(t-\tau)a(\tau)d\tau + \phi(0)a(t) - 0$$

Differentiating again gives

$$\ddot{y} = \int_0^t \ddot{\phi}(t-\tau)a(\tau)d\tau + \phi(0)\dot{a}(t) + \dot{\phi}(0)a(t)$$

Equation (2.4) becomes

$$\int_0^t \ddot{\phi}(t-\tau)a(\tau)d\tau + \phi(0)\dot{a}(t) + \dot{\phi}(0)a(t) + 2\zeta\omega_n \left(\int_0^t \dot{\phi}(t-\tau)a(\tau)d\tau + \phi(0)a(t) \right) + \omega_n^2 \int_0^t \phi(t-\tau)a(\tau)d\tau = a(t)$$

or combining all the integral terms under a single integral sign

$$\int_0^t (\ddot{\phi}(t-\tau) + 2\zeta\omega_n\dot{\phi}(t-\tau) + \omega_n^2\phi(t-\tau))a(\tau)d\tau + \phi(0)\dot{a}(t) + \dot{\phi}(0)a(t) = a(t) \quad (2.28)$$

Equation (2.28) will be an identity if ϕ satisfies the homogeneous version of Eq. (2.4) with $\phi(0)=0$ and its first derivative equal to unity. The integrand in Eq. (2.28) vanishes because the function satisfies the differential equation. The coefficient of $\dot{a}(t)$ vanishes, and the coefficient of $a(t)$ is unity. The function $\phi(t)$ is the solution for the unit impulse that we have already seen, and so we can write this for any value of ζ in terms of the two general exponents for the homogeneous equation.

$$\phi(t-\tau) = \frac{e^{s_1(t-\tau)} - e^{s_2(t-\tau)}}{s_1 - s_2} \quad (2.29a)$$

We can write this in terms of a general argument, replacing $t-\tau$ by ξ , to give Eq. (2.29b)

$$\phi(\xi) = \frac{e^{s_1\xi} - e^{s_2\xi}}{s_1 - s_2} \quad (2.29b)$$

This works because the two exponentials each satisfy the differential equation. The equation is linear, so their sum does as well. It is easy to establish that the initial conditions (here when the general argument $\xi=0$) are as promised. It is worth noting that the underdamped version of Eq. (2.29b) is

$$\phi(\xi) = \exp(-\zeta\omega_n\xi) \frac{\sin(\omega_d\xi)}{\omega_d} \quad (2.29c)$$

the same as Eq. (2.21). The particular solution given by Eq. (2.27) and its first derivative both vanish at $t=0$, the former by inspection, and the latter as follows:

$$\dot{y} = \phi(0)a(t) + \int_0^t \dot{\phi}(t-\tau)a(\tau)d\tau$$

The first term vanishes because $\phi(0)$ does and the second vanishes by inspection—the interval of integration goes to zero. This particular solution does not contribute

Fig. 2.15 Three springs in parallel

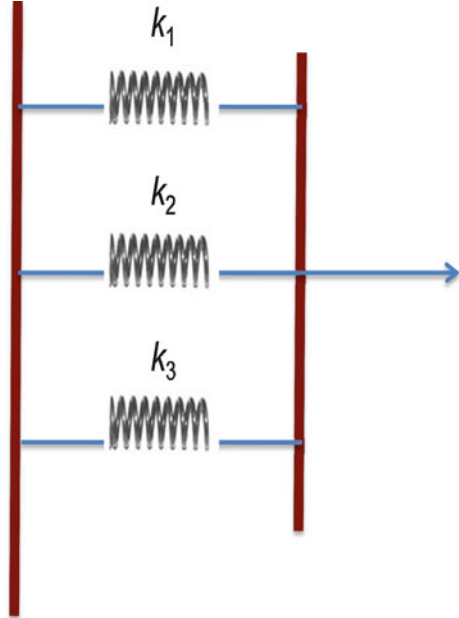

to the initial conditions. The initial conditions for the problem are taken care of entirely by the homogeneous solution. We can incorporate the initial conditions by adding an appropriate homogeneous solution, that given by Eq. (2.15).

This particular solution is restricted to one degree of freedom problems, but we will find similar integral expressions for problems of arbitrary complexity later.

2.3.3 Combining Springs and Dampers

Mechanical systems, even one degree of freedom systems, can have more than one spring or damper. We need to know how to combine springs and dampers to form effective springs and dampers so that we can use what we have learned about Eq. (2.4) for more complicated situations. Fortunately the rules are simple and straightforward and the same for dampers as for springs. I will work them out for springs.

The relation between force and displacement for a spring is linear, and the proportionality constant is the spring constant: $f = k\delta y$. We can find the spring constant by finding the relation between displacement and force. Figure 2.15 shows three springs in parallel.

We see that the force is the sum of the forces in the three springs so that the effective spring constant is simply the sum of the three individual constants. In equation form

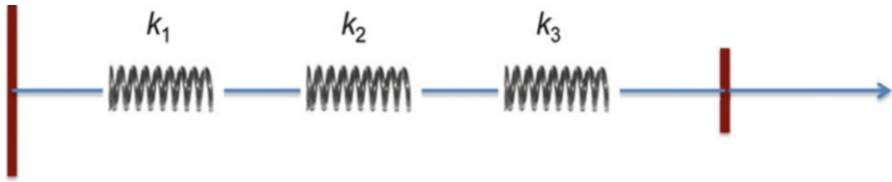

Fig. 2.16 Three springs in series

$$f = k_1\delta y + k_2\delta y + k_3\delta y = (k_1 + k_2 + k_3)\delta y$$

so that

$$k_{\text{eff}} = (k_1 + k_2 + k_3) \quad (2.30a)$$

Figure 2.16 shows three springs in series.

The system is stationary so the force between springs must be zero. Therefore, the force in each spring is the same, so each will deform in response to that force and the total displacement will be

$$\delta y = \frac{f}{k_1} + \frac{f}{k_2} + \frac{f}{k_3}$$

We can solve this for f in terms of the spring constants

$$f = \frac{\delta y}{\frac{1}{k_1} + \frac{1}{k_2} + \frac{1}{k_3}} = \frac{k_1 k_2 k_3}{k_1 k_2 + k_1 k_3 + k_2 k_3} \delta y$$

so that the effective spring constant is given by

$$k_{\text{eff}} = \frac{1}{\frac{1}{k_1} + \frac{1}{k_2} + \frac{1}{k_3}} = \frac{k_1 k_2 k_3}{k_1 k_2 + k_1 k_3 + k_2 k_3} \quad (2.30b)$$

In summary the effective spring constant of springs in parallel is the sum of the individual spring constants; the effective spring constant of springs in series is the inverse of the sum of the inverses. If an electric analogy is helpful to you, you can say that springs in parallel add like resistors in series and springs in series add like resistors in parallel or that springs are the mechanical analog of capacitors.

The same combination rules apply to dampers. I leave it to you to verify this.

2.3.4 Measuring the Damping Ratio

So far this chapter has assumed that the parameters for Eq. (2.4) are given. Suppose we have some vibrating system that we think can be represented by a one degree of freedom model. We can hear or feel something that sounds like a vibration. If we want to analyze it further, we would need to provide values for the natural frequency and damping ratio. We know that the damping ratio is less than one or there would not be a detectable vibration. The model system must be underdamped. We might excite the system (e.g., by providing an impulse) and get a picture like Figure 2.9.

Can we deduce what we need to know from these data? We will learn methods for finding natural frequencies for systems of any complexity later. We can estimate the frequency for the sample data by simply counting zero crossings. We know that the system is underdamped because it is oscillating and decaying. How can we find the damping ratio from the data in Fig. 2.9? This is a traditional exercise. Extending it to more than one degree of freedom is not trivial, but the technique is intriguing and worth addressing.

We know the response to an underdamped system is of the form

$$y = \exp(-\zeta\omega_n t)(A \cos(\omega_d t) + B \sin(\omega_d t))$$

If the response is to an impulse, $A=0$, so we can write the response as [see Eq. (2.29c)]

$$y = Y \exp(-\zeta\omega_n t) \sin(\omega_d t)$$

The successive peaks are at $t_n = (2n+1)\pi/\omega_d$ and so their values are

$$y_n = Y \exp\left(-\zeta\omega_n \frac{(2n+1)\pi}{\omega_d}\right) = Y \exp\left(-\frac{\zeta}{\sqrt{1-\zeta^2}}(2n+1)\pi\right)$$

This expression is independent of the natural frequency, and if we take ratios, we can make it independent of the amplitude Y . We have

$$\frac{y_n}{y_{n+1}} = \frac{\exp\left(-\frac{\zeta}{\sqrt{1-\zeta^2}}(2n+1)\pi\right)}{\exp\left(-\frac{\zeta}{\sqrt{1-\zeta^2}}(2n+3)\pi\right)} = \exp\left(\frac{\zeta}{\sqrt{1-\zeta^2}}2\pi\right)$$

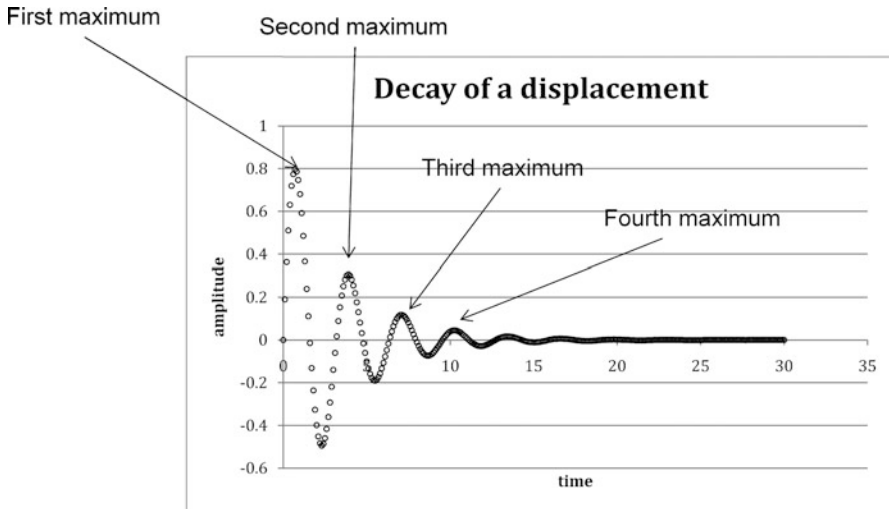

Fig. 2.17 A digital record of some artificial data

Take the logarithm of this

$$\delta = \ln\left(\frac{y_n}{y_{n+1}}\right) = 2\pi \frac{\zeta}{\sqrt{(1-\zeta^2)}} \quad (2.31)$$

The quantity δ is called the *log decrement*. We can measure the log decrement and solve the equation for the damping ratio.

$$\zeta = \frac{\delta}{\sqrt{(4\pi^2 + \delta^2)}} \quad (2.32)$$

Note that the ratio is the same for each successive point, so one can measure several of these and arrive at an estimate based on several values of the ratio.

Example 2.5 Finding the Damping Ratio from Artificial Data Figure 2.17 shows a digital sampling of a decay curve for a system with a damping ratio of 0.15

$$y = \exp(-0.15\omega_n t) \sin(0.9887\omega_n t)$$

I eyeballed the data from the figure and built a table of successive maxima. I calculated ratios from these maxima, calculated the logarithms, then the damping ratios, and finally averaged the damping ratios, obtaining 0.1500, a very good estimate of the actual damping ratio. Table 2.1 shows the calculations.²

² Calculated using spreadsheet software.

Table 2.1 Estimating the damping ratio from artificial data

Eyeball			
Maxima	Ratios	ln(ratios)	Zetas
0.7965	2.592773438	0.952728128	0.149917725
0.3072	2.596787828	0.95427523	0.150155687
0.1183	2.605726872	0.957711666	0.150684156
0.0454	2.583949915	0.949319203	0.149393302
0.01757			0.150037717

Fig. 2.18 A one degree of freedom system excited by motion of its support

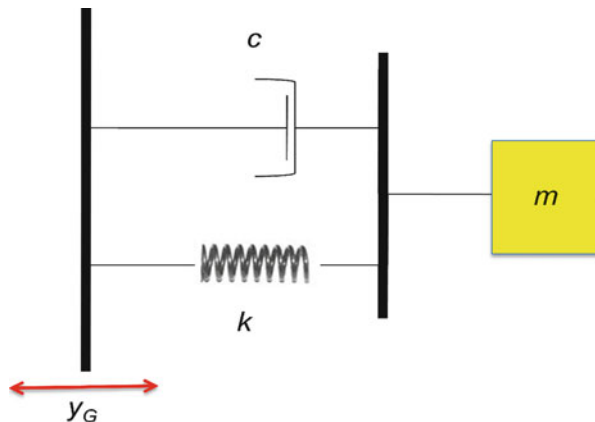

2.3.5 Support Motion

I stated earlier that we can drive the mass by moving the support. We can redraw Fig. 1.2 with the external forcing replaced by an imposed displacement, shown in Fig. 2.18. The equation of motion associated with this system is

$$m\ddot{y} = -k(y - y_G) - c(\dot{y} - \dot{y}_G) \Rightarrow \ddot{y} + 2\zeta\omega_n\dot{y} + \omega_n^2y = 2\zeta\omega_n\dot{y}_G + \omega_n^2y_G$$

where y_G denotes the motion of the support. (I use the subscript G because the support will frequently be the ground.) The right-hand side plays the role of the acceleration a in Eq. (2.4). We can make the essential points more clearly if we neglect damping and suppose that the support motion is harmonic. Then we will have

$$\ddot{y} + \omega_n^2y = \omega_n^2Y_G \sin(\omega_G t)$$

In this simple case y will also be proportional to $\sin(\omega_G t)$ and we find that

$$y_P = \frac{\omega_n^2 Y_G}{\omega_n^2 - \omega_G^2} \sin(\omega_G t) = \frac{Y_G}{1 - r^2} \sin(\omega_G t)$$

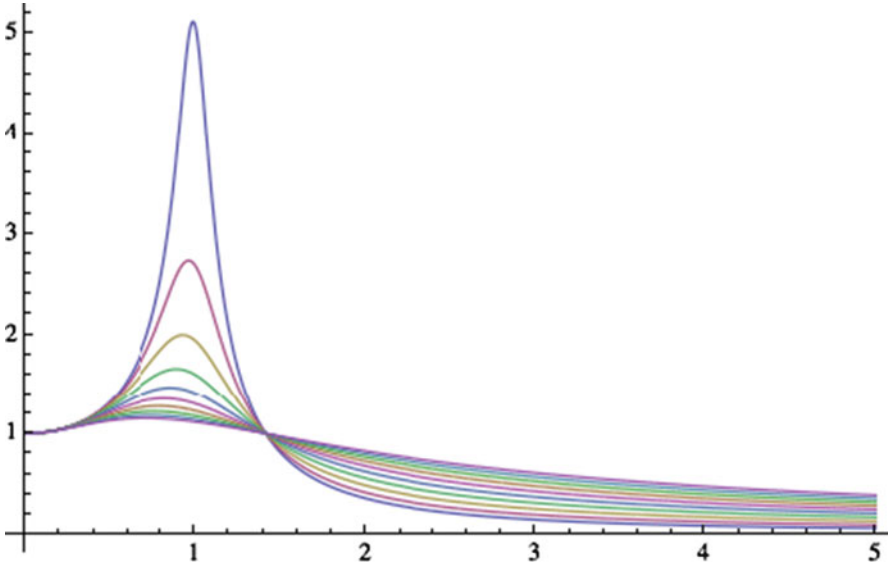

Fig. 2.19 Normalized response to harmonic ground motion

where r now denotes the ratio of the ground motion frequency to the natural frequency: $r = \omega_G/\omega_n$. Note that I have labeled this as a particular solution. It is fairly common to neglect the homogeneous solution in applications. All real systems have some damping, and the transients before damping can have its effect are often not interesting. When only the particular solution is used, it is called the *steady solution*, even though it is not actually steady, but a harmonic function of time at the same frequency as the driving input. The engineer has to decide when it is appropriate to use this steady (particular) solution. Generally the steady solution is fine if the transients are unimportant (or unknown).

There are two extreme limits. If ω_G is small compared to the natural frequency (small r), then the amplitude of the response is approximately equal to the input. If we add damping we get a somewhat more complicated expression, which I leave to the reader. Figure 2.19 shows the response normalized to the amplitude of the ground motion for the same range of damping ratios as in Fig. 2.14. Note the qualitative resemblance to Fig. 2.14. The quantitative differences stem from the appearance of the damping in the acceleration term.

The force on the mass also varies with forcing frequency, but not in the same way.

Figure 2.20 shows the normalized force for the same set of parameters:

$$\frac{f}{kY_G} = \frac{(y - y_G)}{Y_G} + 2\zeta \frac{(\dot{y} - \dot{y}_G)}{\omega_n Y_G}$$

The force is zero at zero forcing frequency (nothing happens) and increases as the forcing frequency increases. The higher the damping ratio, the higher the force for large forcing frequency.

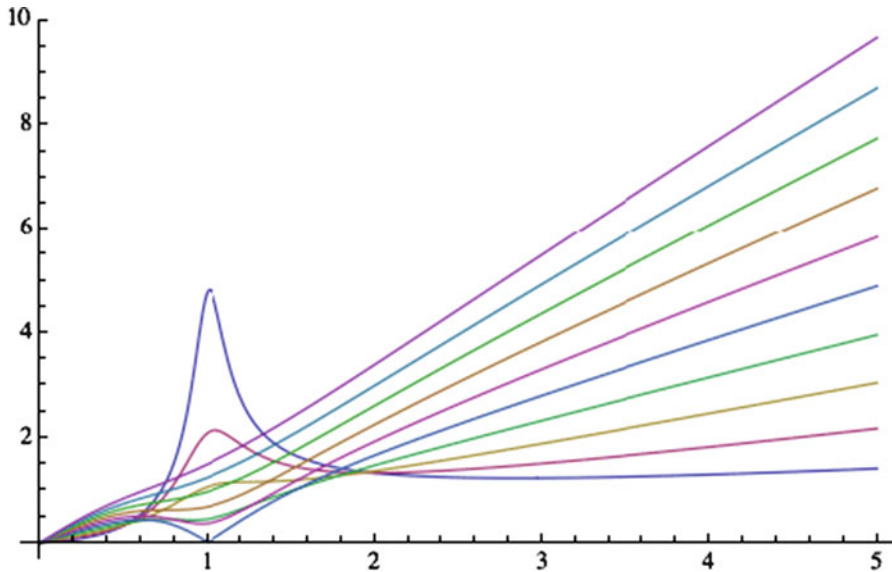

Fig. 2.20 Normalized force on the mass (see text)

2.4 Applications

2.4.1 Unbalanced Rotating Machinery

A piece of rotating machinery will react on its supports when rotating if it is not balanced. Examples include everything from an asymmetrically loaded washing machine to the turbine rotors in a jet engine. Automobile tires provide a homely example. We can look at this as a one degree of freedom if we suppose motion to be possible in only one direction.

Figure 2.21 shows a model of a system with a rotational imbalance. The small mass m rotates with the central shaft and is offset a distance d from the rotation axis. The shaft rotates at a rate ω as shown. We make this a one degree of freedom system by supposing the machine to be constrained to purely vertical motion. The unbalanced mass exerts a centripetal force on the axle, hence on the machine. If we denote the angle the unbalanced mass makes with the vertical by $\theta(=\omega t)$, then we can write the vertical component of the centripetal force as $md\omega^2 \cos \theta$, and we can write Eq. (2.4) as

$$\ddot{z} + 2\zeta\omega_n\dot{z} + \omega_n^2 z = \left(\frac{md}{M}\omega^2\right) \cos(\omega t) = \left(\frac{md}{M}\omega^2\right) \sin\left(\omega t - \frac{\pi}{2}\right)$$

In engineering practice we care about the long-term behavior of this system—will it shake itself apart or destroy its mount? Therefore we do not care about the

Fig. 2.21 Rotating machine with an imbalanced rotor

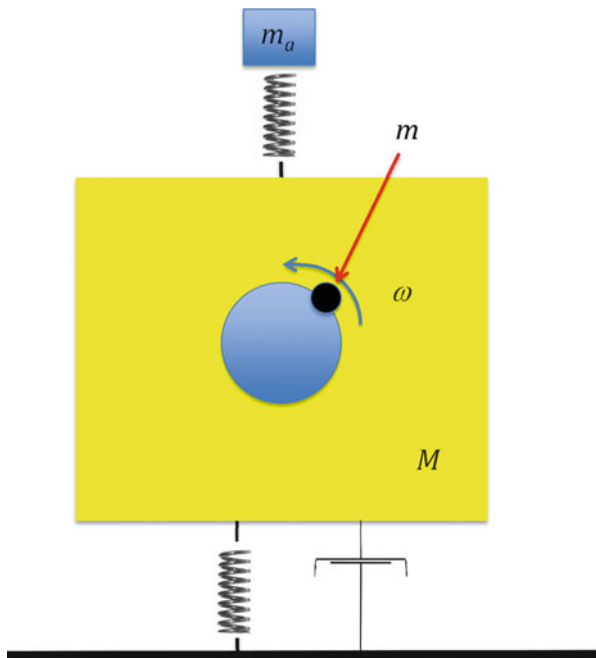

transient for this problem and can address the particular solution alone. This is a harmonically forced damped system, and we know the particular solution. We simply modify Eq. (2.13a) to obtain

$$z_P = -\frac{2\zeta\omega_f\omega_n}{(\omega_n^2 - \omega_f^2)^2 + (2\zeta\omega_f\omega_n)^2} \left(\frac{md}{M}\omega_f^2\right) \cos\left(\omega_f t - \frac{\pi}{2}\right) + \frac{(\omega_n^2 - \omega_f^2)}{(\omega_n^2 - \omega_f^2)^2 + (2\zeta\omega_f\omega_n)^2} \left(\frac{md}{M}\omega_f^2\right) \sin\left(\omega_f t - \frac{\pi}{2}\right)$$

where I have added a subscript f to the forcing frequency for clarity. We can write this in a more compact form

$$z_P = -\frac{2\zeta r}{\left((1 - r^2)^2 + (2\zeta r)^2\right)} \left(\frac{md}{M}r^2\right) \sin(\omega_f t) - \frac{(1 - r^2)}{\left((1 - r^2)^2 + (2\zeta r)^2\right)} \left(\frac{md}{M}r^2\right) \cos(\omega_f t) \quad (2.33)$$

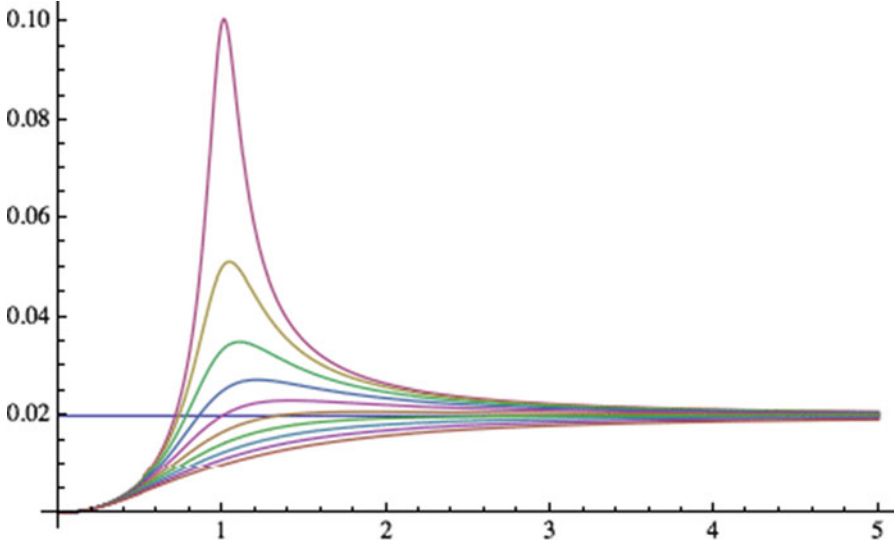

Fig. 2.22 Normalized displacement vs. exciting frequency

The amplitude of this can be gotten by substitution into Eq. (2.13b). That result is

$$\frac{1}{\sqrt{(1-r^2)^2 + (2\zeta r)^2}} \frac{m}{M} r^2 d \quad (2.34)$$

Now we see that the displacement is small at small forcing frequencies and is asymptotically equal to the mass ratio times the offset as the forcing frequency increases. (In most circumstances the product md is the only variable available. The actual location of the imbalance is not easily found. In the case of balancing a tire, weights are placed on the rim, so d and m can be determined independently for the compensatory weights.) Figure 2.22 shows the displacement divided by d for a mass ratio of $1/50$. You can see the effects of resonance and the asymptotic result.

The force transmitted to the ground is often important. We can also obtain that from prior work. In this case the ground is not moving, so we have

$$f = kz + c\dot{z} = M(\omega_n^2 z + 2\zeta\omega_n\dot{z})$$

We can plot the amplitude of f/dk as a function of the frequency ratio and the damping ratio, as we did for the displacement. That result is shown in Fig. 2.23.

Example 2.6 The Rotary Lawn Mower Consider the rotary lawn mower as a real-life example of a rotating imbalance with one degree of freedom (at least in a very simple model for which the wheels prevent sideways motion). Figure 2.24

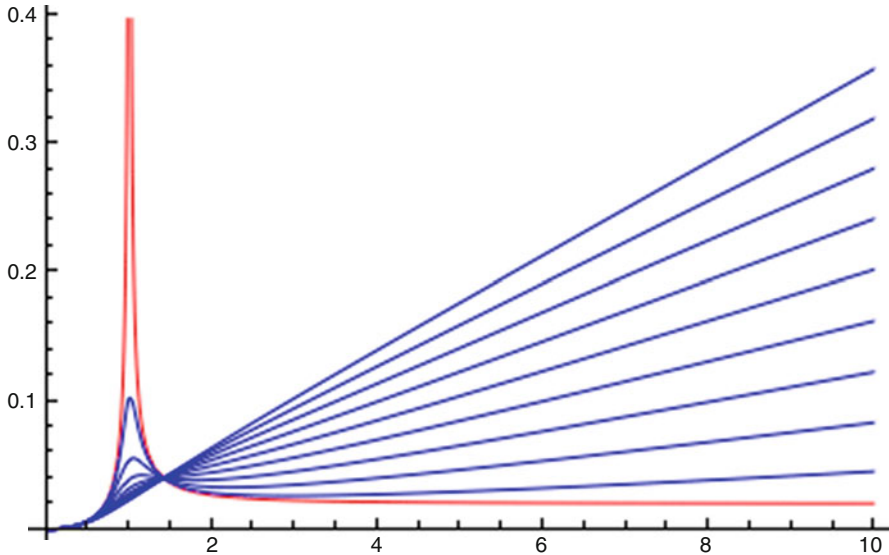

Fig. 2.23 Dimensionless ground force for the imbalanced rotor. The *red curve* is the undamped case. The *blue curves* show damping ratios from 0.1 to 0.9 in 0.1 increments. Damping increases the transmitted force for high frequency excitation

shows the bottom of a rotary lawn mower deck. It is reasonable to suppose that the wheels prevent transverse motion, so that the only motion that might be generated by an imbalance is in the nominal direction of travel. The force resisting this is complicated, requiring us to understand the interaction of the wheels with grass-covered ground. Since this is well beyond the scope of this text, let's take a very simple model and suppose there is no rolling resistance.

The blade shown is 533 mm (21") long and its width is 54 mm (2 1/8"). Its mass is 0.70 kg (weight 1 lb 8.5 oz), and it is made of steel. The mower wheel base is 686 mm (27") and its track is 508 mm (20"). We can model the blade as a uniform steel bar with the same mass and length and a reasonable width, a bar 533 mm long, 54 mm wide, and 3.10 mm thick. I take the mass of the entire lawn mower to be 15 kg.

How fast does the blade turn? Federal law limits the tip speed of the blade to 96.5 m/s (19,000 fpm). This speed is attained at approximately 3,460 rpm for this blade. Browsing the Internet suggests that rotary push lawn mower engines are set between 3,000 and 3,300 rpm. We can adopt some reasonable number, say 3,200 rpm, to explore the possible vibrations of this system caused by blade imbalance. The equation of motion for the system as a whole is

$$M\ddot{y} = md\omega^2 \cos(\omega t)$$

where M denotes the entire mass, md the unbalanced moment, and ω the rotation rate. The response is a simple 180° out of phase motion of amplitude md/M . This agrees with Eq. (2.31) in the limit that r goes to infinity—zero natural frequency. The worst case would have the location of the imbalance at the end of the blade,



Fig. 2.24 Lawn mower bottom (photo by the author)

so that we have an amplitude of 10.5 m/M inches. The unbalanced mass will be a small fraction of the blade mass, which is a small fraction of the system mass, so we do not expect much motion. However, there is a still a radial force on the motor bearings of $1.123 \times 10^5 \text{ mdN}$. A one gram unbalanced weight at the end of the blade makes this number approximately 30 N, not a negligible load on a bearing.

2.4.2 Simple Air Bag Sensor

The actual air bag sensor is a MEMS³ device that we can look at as a small cantilever beam as shown in Fig. 2.25. We can fit this into our one degree of freedom model by finding the spring constant of the beam, either experimentally or by calculating it (beyond our capabilities at the moment). If the mass is much larger than the mass of the beam, then the calculation is simple, based on bending of a cantilever beam under end loading. I leave that to you. We are going to need to design an appropriate system eventually. For now, note that the system can be redrawn to fit into our model of a system driven by the motion of its support, as shown in Fig. 2.26. The sensor assembly is rigidly attached to the car so that the motion of the case of the assembly is the same as that of the car.

³ Microelectromechanical systems.

Fig. 2.25 A simple sketch of an air bag sensor

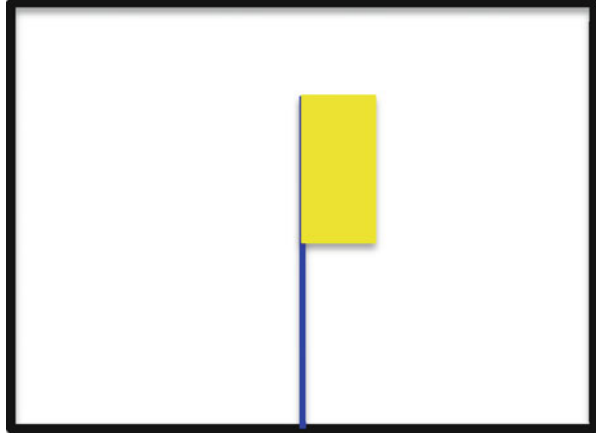
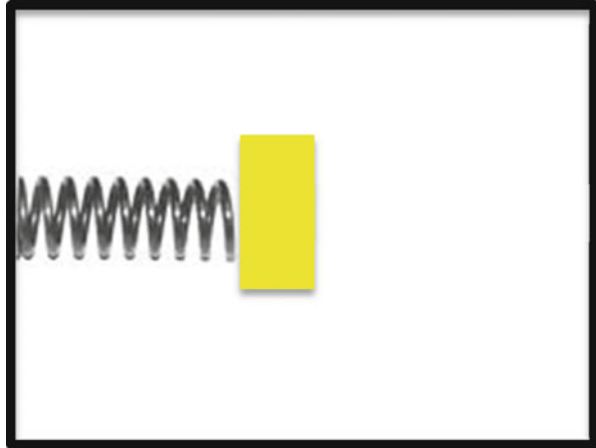

Fig. 2.26 Idealized model of an air bag sensor



Suppose the whole system to be moving to the right. When the vehicle hits a tree, the case stops, but the mass wants to keep moving. If the mass moves far enough, it will trigger the air bag, so we need to calculate how far it will travel for a given deceleration. Denote the position of the mass with respect to the case by y , and denote the motion of the case by y_W . The basic force balance is

$$m(\ddot{y} + \ddot{y}_W) = -c\dot{y} - ky$$

which can be converted to an equivalent of Eq. (2.4)

$$\ddot{y} + 2\zeta\omega_n\dot{y} + \omega_n^2y = -\ddot{y}_W$$

We can get a general picture of how this works by neglecting damping (which will be small in any case) and assuming a constant deceleration. We need to solve

$$\ddot{y} + \omega_n^2 y = -a_0$$

subject to zero initial conditions. This is a problem for which the transient is all. Either the mass triggers the air bag during its first swing or it never will. This clearly depends on the deceleration (note that constant a_0 is a negative number) and the natural frequency. The particular solution is constant, and the homogeneous solution is the usual expression in terms of sine and cosine. The final result after applying initial conditions is

$$y = \frac{a_0}{\omega_n^2} (1 - \cos(\omega_n t))$$

I plot a scaled version as Fig. 2.27.

We see that the maximum displacement is twice the acceleration divided by the natural frequency and that it takes place at $\omega_n t = \pi$. We want the air bag to trigger early in the crash process, so we want a high natural frequency. The larger the design frequency, the smaller the response for a given deceleration, so we want the critical displacement to be small. Finally, we want the air bag to deploy only when the deceleration is extreme, more than one would expect from normal operation of the vehicle.

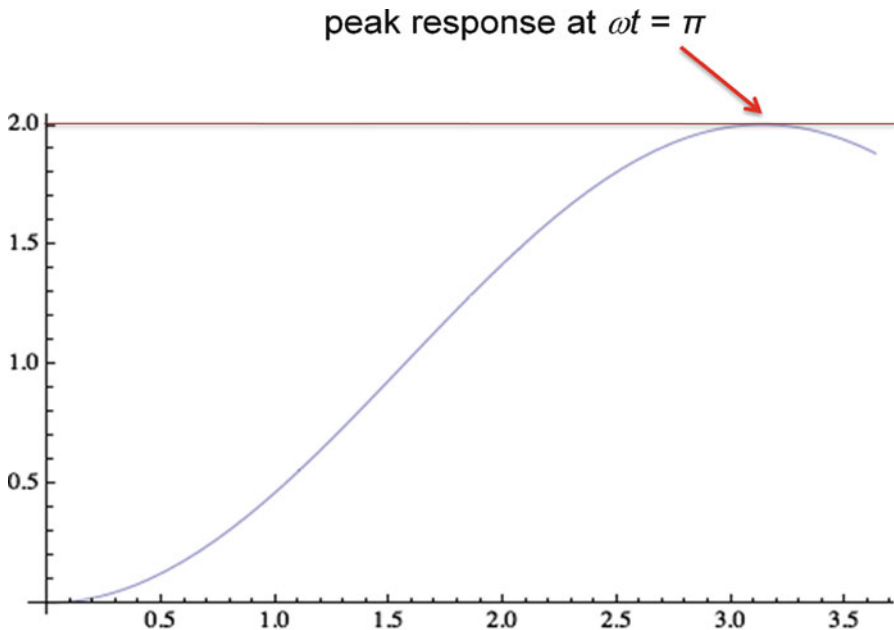

Fig. 2.27 Air bag sensor response

2.4.3 Seismometers and Accelerometers

Both seismometers and accelerometers work on the same principle as the air bag sensor. They have a proof mass connected to their world by a spring (and usually some sort of damper, whether deliberate or a consequence of natural dissipation) and a sensor that can detect motion between the proof mass and its world. The former measures displacement of the Earth and the latter the acceleration of whatever object it is attached to. How, then, are they different? We can address this question by considering again the simple one degree of freedom problem driven by ground motion.

Denote the motion of the proof mass by y and that of its world by y_G . The governing differential equation can be reduced to our standard form (recall how to do this)

$$\ddot{y} + 2\zeta\omega_n\dot{y} + \omega_n^2y = 2\zeta\omega_n\dot{y}_G + \omega_n^2y_G$$

where ζ denotes the damping ratio and ω_n the natural frequency (here k/m). These systems require an unsteady input, and we can characterize such an input by some characteristic frequency. (In the case of a more complicated input, we can characterize that by a suite of frequencies.) The response will depend on the input frequency. Let

$$y_G = Y_G \sin(\omega_G t)$$

where Y_G is a constant and ω_G is the characteristic frequency. Substituting this into the differential equation leads to

$$\ddot{y} + 2\zeta\omega_n\dot{y} + \omega_n^2y = 2\zeta\omega_n\omega_G Y_G \cos(\omega_G t) + \omega_n^2 Y_G \sin(\omega_G t)$$

We care about the particular solution. (I'll say a little more about this when we've done the analysis.) The forcing is harmonic at ω_G and the particular solution must also be harmonic at ω_G . We can write

$$y = Y_1 \cos(\omega_G t) + Y_2 \sin(\omega_G t)$$

and substitute that into the differential equation. There will be sine and cosine terms on both sides of the equation, and they must satisfy the equation independently. The final result for the differential motion will be

$$y - y_G = \frac{2\zeta r^3}{(1 - r^2)^2 + 4\zeta^2 r^2} Y_G \cos(\omega_G t) + \frac{r^2(1 - r^2)}{(1 - r^2)^2 + 4\zeta^2 r^2} Y_G \sin(\omega_G t)$$

where r denotes the ratio of the exciting frequency to the natural frequency: $r = \omega_G/\omega_n$. The damping will be small so that ζ is less than unity, probably considerably less than unity. The amplitude and phase of this signal are given by

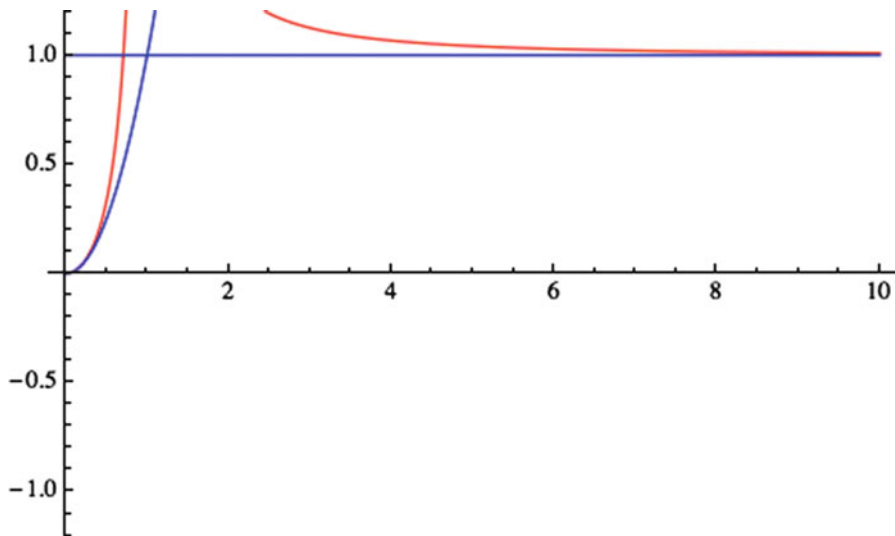

Fig. 2.28 The normalized amplitude of the response of an instrument driven by ground motion. The horizontal axis is the ratio of the exciting frequency to the natural frequency. The horizontal line is unity, and the curve is r^2 . The damping ratio is zero, and the large values of the red curve cut off represent resonance at $r = 1$

$$A = \frac{r^2}{\sqrt{(1-r^2)^2 + 4\zeta^2 r^2}} Y_G, \quad \phi = \tan^{-1} \left(\frac{2r}{1-r^2} \right)$$

Figures 2.28, 2.29, and 2.30 show the amplitude divided by Y_G vs. r for r from zero to ten in red for damping ratios of 0, 1 (critically damped), and 0.707. The two blue lines are r^2 and unity, respectively. We see that the response for small r goes like the square of r , and for large r the response tends to a constant. Zero damping is clearly inadmissible, and critical damping reduces the range where the blue and red curves coincide. The intermediate damping seems to be a good choice. I encourage you to investigate this question further.

Figure 2.30 suggests that we can use this instrument to measure different things depending on whether r is large or small.

2.4.3.1 Seismometers

If r is large, then

$$y - y_G \approx \frac{2\zeta}{r} Y_G \cos(\omega_G t) - Y_G \sin(\omega_G t) \approx -Y_G \sin(\omega_G t)$$

The amplitude tends to Y_G and the phase to $-\pi$. The differential signal is proportional to the input displacement and 180° out of phase with it. The sensor will measure the displacement of the ground. Large r means that the natural frequency is

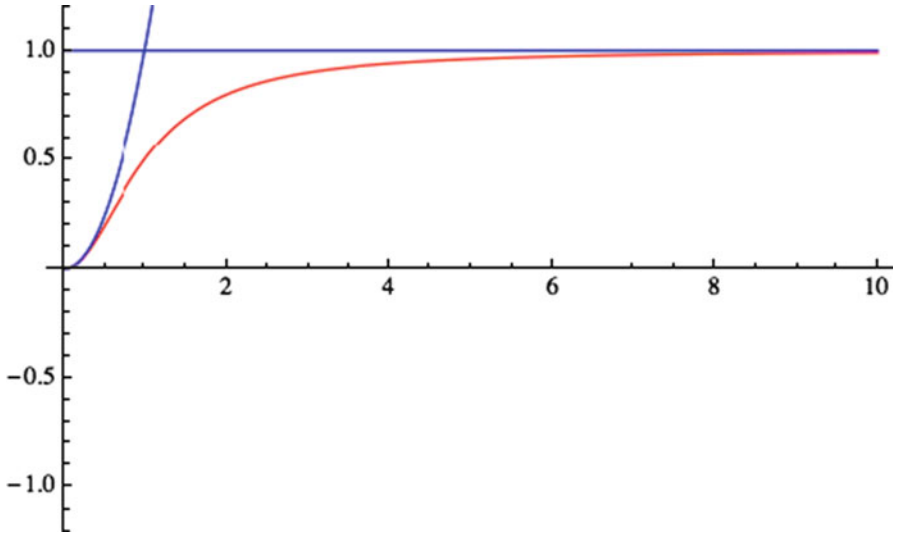

Fig. 2.29 The normalized amplitude of the response of an instrument driven by ground motion. The horizontal axis is the ratio of the exciting frequency to the natural frequency. The horizontal line is unity, and the curve is r^2 . The damping ratio is unity

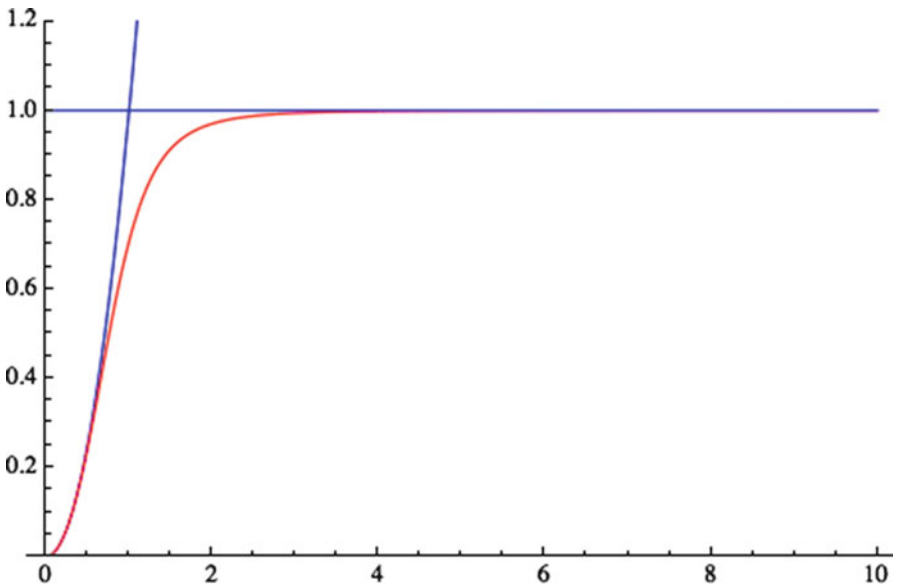

Fig. 2.30 The normalized amplitude of the response of an instrument driven by ground motion. The horizontal axis is the ratio of the exciting frequency to the natural frequency. The horizontal line is unity, and the curve is r^2 . The damping ratio is 0.707

small compared to the displacement frequency—a large mass and a weak spring. Such a device can function as a seismometer, measuring ground motion at frequencies greater than its own natural frequency. Figure 2.30 suggests that ground motions at more than three times the natural frequency can be reliably measured. Maximum earthquake frequencies are about 20 Hz (with significant energies well below 1 Hz), so seismometers need very low natural frequencies. We can attain low frequencies (in mechanical seismometers) by using a horizontal pendulum. We know that the natural frequency of a pendulum is given by

$$\omega_n^2 = \frac{g}{l}$$

If the pendulum is nearly horizontal the effective gravity is reduced and periods in excess of 30 s can be easily attained. It is also fairly easy to add damping to any such system using a damper at the pivot.

Let's take a look at how a pendulum responds to the motion of its pivot point. We don't need to worry about the horizontal aspect, just suppose that the effective gravitational constant is reduced. We can start with the same pendulum equations we had earlier in this chapter

$$\begin{aligned} m\ddot{y} &= -T \sin \theta \\ m\ddot{z} &= T \cos \theta - mg \end{aligned}$$

The difference is that we must replace y by a term that takes account of the pivot motion:

$$y = y_G + l \sin \theta$$

The expression for z remains the same. It is an easy matter to follow the pendulum argument to arrive at the modified equation for the pendulum [the equivalent of Eq. (2.12a)]

$$\ddot{\theta} + \frac{g}{l} \sin \theta = -\cos \theta \frac{\ddot{y}_G}{l}$$

which linearizes to

$$\ddot{\theta} + \frac{g}{l} \theta = -\frac{\ddot{y}_G}{l}$$

We can add damping proportional to the rotation rate of the pendulum, to give

$$\ddot{\theta} + \frac{c}{ml} \dot{\theta} + \frac{g}{l} \theta = -\frac{\ddot{y}_G}{l}$$

We can use this to design our damping. If we want $\zeta = 0.707$, as in Fig. 2.28, we simply write

$$\frac{c}{ml} = 2\zeta\sqrt{\frac{g}{l}} \rightarrow c = 2\zeta m\sqrt{gl}$$

2.4.3.2 Accelerometers

On the other hand, if r is small, then we have

$$y - y_G \approx 2\zeta r^3 Y_G \cos(\omega_G t) + r^2 Y_G \sin(\omega_G t) \approx \frac{\omega_G^2}{\omega_n^2} Y_G \sin(\omega_G t)$$

The amplitude tends to

$$r^2 Y_G = \frac{\omega_G^2}{\omega_n^2} Y_G$$

and the phase to zero. The output provides a direct measurement of the acceleration ($\omega_G^2 y_G$) of the object to which the instrument is attached. This device can measure acceleration at frequencies below the natural frequency of the instrument, so a high natural frequency is desired. An accelerometer requires a tiny proof mass and a very stiff spring. I will discuss actual accelerometers in Chap. 5.

Note that neither instrument is all that much affected by the damping, so moderate damping (say $\zeta = 1/\sqrt{2}$) can be introduced to reduce any ringing from the sudden onset of the signal.

2.5 Preview of Things to Come

2.5.1 Introduction to Block Diagrams

We will have occasion to use block diagrams frequently in the course of this text. Block diagrams provide schematic diagrams equivalent to the differential equations governing any given system. Sometimes (for many people) this visual picture makes it easier to understand the dynamics. (Some people are content with the differential equations.) I will introduce block diagrams here in this simple setting, using the standard form of the one degree of freedom system as given by Eq. (2.4), reproduced here for convenience,

$$\ddot{y} + 2\zeta\omega_n\dot{y} + \omega_n^2 y = a \quad (2.4)$$

I want to draw a picture of Eq. (2.4). The differential equation relates a function and its derivatives to the input. The mathematical operations are all differentiations. The mathematical operations in a block diagram are all integrations. The block diagram is, in some sense, the inverse of the differential equation.

Let's put together a block diagram of Eq. (2.4). This is a second-order equation involving two differentiations. Its block diagram equivalent will require two

Fig. 2.31 (a) The spine of a second-order system. (b) Block diagram of the standard one degree of freedom system (Eq. 2.4)

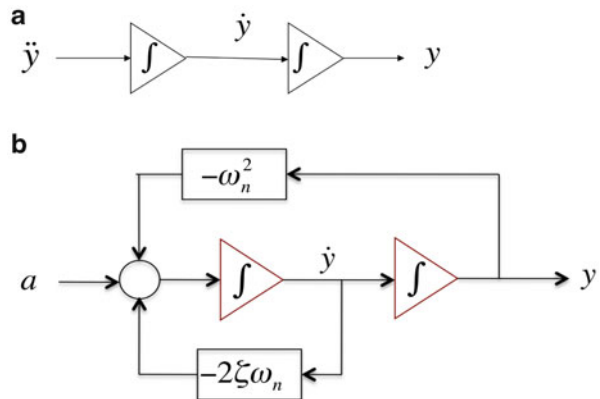

integrations, which I will denote by triangles. There will be what I can call a second-order spine at the heart of the diagram, which I show as Fig. 2.31a.

One reads this diagram form left to right. We start with \ddot{y} , integrate to get \dot{y} , and then integrate a second time to get y . (It is conventional to ignore initial conditions when drawing block diagrams.) To complete the block diagram we need to have a picture of \ddot{y} , which we can obtain by solving Eq. (2.4) for \ddot{y} :

$$\ddot{y} = -2\zeta\omega_n\dot{y} - \omega_n^2 y + a$$

There are three contributions to the second derivative—one from the input and one each from y and its first derivative. Once we have the second derivative, we integrate twice to get y . This is shown in Figure 2.31b, where I represent addition by a circle and multiplication by a box. The block diagram of the standard one degree of freedom system is shown as Fig. 2.31b.

The circle at the left gathers all three inputs to the second derivative: the actual input and the two “feedback” inputs. I put feedback in quotation marks here because I intend to use the word in a somewhat different sense later in the text. In both the present and future cases, the feedback is literally a feedback—already calculated variables are fed back to the beginning. The diagram is of what is called an *open-loop* system, open because there is no direct connection from the output y to the input a . Closing the loop, adding a connection from y back a , would make it a closed-loop system, and the connection is what we will generally mean by *feedback*. This process is the core of the second half of the text, beginning in Chap. 7.

Figure 2.31b shows a scalar block diagram, and it has two integrators. We can make a vector diagram of this and have a single (vector) integrator. This will be the way we will represent complicated systems later in the text, so it is a good idea to

see how this goes. The easiest way to develop this picture is to go through the analysis. Instead of treating y and its derivative as connected scalars, we treat them as the components of a vector

$$\mathbf{x} = \begin{Bmatrix} y \\ \dot{y} \end{Bmatrix}, \quad y = \{1 \quad 0\} \mathbf{x}$$

and then write the differential equations for this vector

$$\frac{d}{dt} \begin{Bmatrix} y \\ \dot{y} \end{Bmatrix} = \begin{Bmatrix} \dot{y} \\ -\omega_n^2 y - 2\zeta\omega_n \dot{y} + a \end{Bmatrix}$$

Split out the external acceleration while maintaining the vector nature of the equations

$$\frac{d}{dt} \begin{Bmatrix} y \\ \dot{y} \end{Bmatrix} = \begin{Bmatrix} \dot{y} \\ -\omega_n^2 y - 2\zeta\omega_n \dot{y} \end{Bmatrix} + \begin{Bmatrix} 0 \\ 1 \end{Bmatrix} a$$

This problem is linear so the homogeneous term on the right-hand side can be rewritten as a matrix times a vector

$$\frac{d}{dt} \begin{Bmatrix} y \\ \dot{y} \end{Bmatrix} = \begin{Bmatrix} 0 & 1 \\ -\omega_n^2 & -2\zeta\omega_n \end{Bmatrix} \begin{Bmatrix} y \\ \dot{y} \end{Bmatrix} + \begin{Bmatrix} 0 \\ 1 \end{Bmatrix} a, \quad y = \{1 \quad 0\} \begin{Bmatrix} y \\ \dot{y} \end{Bmatrix}$$

We can write this system compactly in vector notation for any linear system, not just the simple one degree of freedom problem we are addressing, as Eq. (1.1b) augmented with a scalar output

$$\dot{\mathbf{x}} = \mathbf{A}\mathbf{x} + \mathbf{b}a, \quad y = \mathbf{c}^T \mathbf{x}$$

from which it is easy to draw the vector block diagram (Fig. 2.32)

In fact, this diagram and the accompanying vector equation can be generalized to systems that have more than one input and more than one output. In that case the vectors \mathbf{b} and \mathbf{c} become matrices. This is an example of a state space formulation, but I will defer further discussion of state space until Chap. 6.

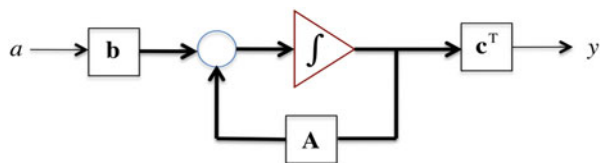

Fig. 2.32 Vector block diagram. The *thick lines* denote vector variables and the *thin lines* scalar variables

2.5.2 Introduction to Simulation: The Simple Pendulum

Most models of engineering problems are nonlinear. We can address linearized versions of these analytically, but frequently this is not sufficient. There is not much one can do analytically with nonlinear problems, and what there is is beyond the scope of this text (although this problem can be pursued further analytically, and I will do that). We can, however, address nonlinear problems numerically by integrating the governing equations. I will refer to this process as *simulation*, and to the results as a *simulation*. Numerical integration in time is usually based on finite differences, replacing the derivatives by differences. The most commonly used integration methods are the various Runge-Kutta schemes. Runge-Kutta schemes have different orders of accuracy. The more accurate the scheme, the longer the integration takes. Fourth-order accuracy is usually chosen, and it is also common to use an adaptive step size routine, taking larger steps where the solution is varying slowly. A thorough discussion of numerical integration is beyond the scope of the text. I refer the interested reader to Press et al. (1992), which not only contains the material but is one of the clearest mathematics books I know. Simulation is not only useful for modeling the dynamics of a mechanism, but it can be used to assess the validity of a linear solution: how well does the linear solution agree with the simulation? I will use commercial software to integrate the nonlinear equations, which can always be converted to a set of quasilinear first-order equations. I did the integrations in this book using Mathematica version 8.0.4.0, for which I believe the integration scheme to be a fourth-order adaptive step size Runge-Kutta scheme.

Example 2.7 Simulating the Simple Pendulum We found a solution for the simple pendulum that was valid for small angles. Let us assess how small these angles need to be by simulating the pendulum, integrating Eq. (2.12a), reproduced here for convenience.

$$\ddot{\theta} + \frac{g}{l} \sin \theta = 0 \quad (2.12a)$$

We can convert this to a pair of first-order equations (state space form) for the state vector

$$\mathbf{x} = \begin{Bmatrix} \theta \\ \dot{\theta} \end{Bmatrix}$$

which gives a pair of coupled ordinary differential equations.

$$\dot{\theta} = \omega, \quad \dot{\omega} = -\frac{g}{l} \sin \theta$$

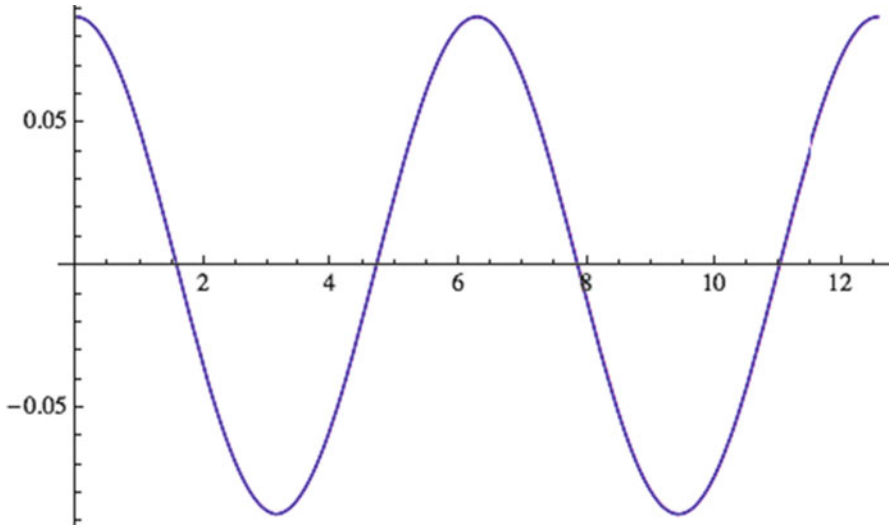

Fig. 2.33 Response of a pendulum started from rest at 5° from vertical

We can compare the linear and nonlinear response by comparing the behavior of the system starting from rest at $\theta = \theta_0$. The linear solution for this case is $\theta_0 \cos(\sqrt{(g/l)t})$. I can set $g = 1 = l$ without loss of generality. This makes the period of the linear pendulum equal 2π .

Figure 2.33 shows the linear and nonlinear response of the pendulum over two linear periods for an initial offset of $\pi/36$ (5°). The nonlinear solution (in red) is overlain almost perfectly by the linear solution, in blue. This suggests that 5° is certainly small enough, at least for a few periods.

There's not much visible difference in two periods for initial offsets of 10° and 15° . We can begin to detect a difference at 20° , as shown in Fig. 2.34. The nonlinear solution lags the linear solution, and, while it is periodic, it is no longer harmonic. (In fact, the nonlinear solution is never harmonic, as I will show eventually.)

If we go to 90° we see a sharp difference between the linear and nonlinear solutions, although the nonlinear solution still looks quite harmonic. This is shown in Fig. 2.35.

Finally, if I start the system in a nearly inverted position (0.99π) the entire character of the nonlinear solution changes, so much so that I have to plot four linear periods to give a good impression of the result, shown in Fig. 2.36.

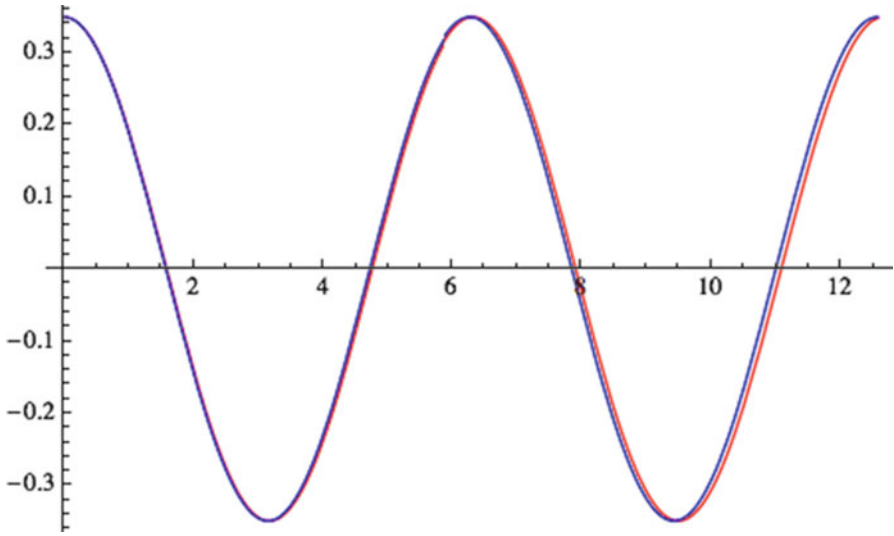

Fig. 2.34 Response of a pendulum started from rest at 20° from vertical

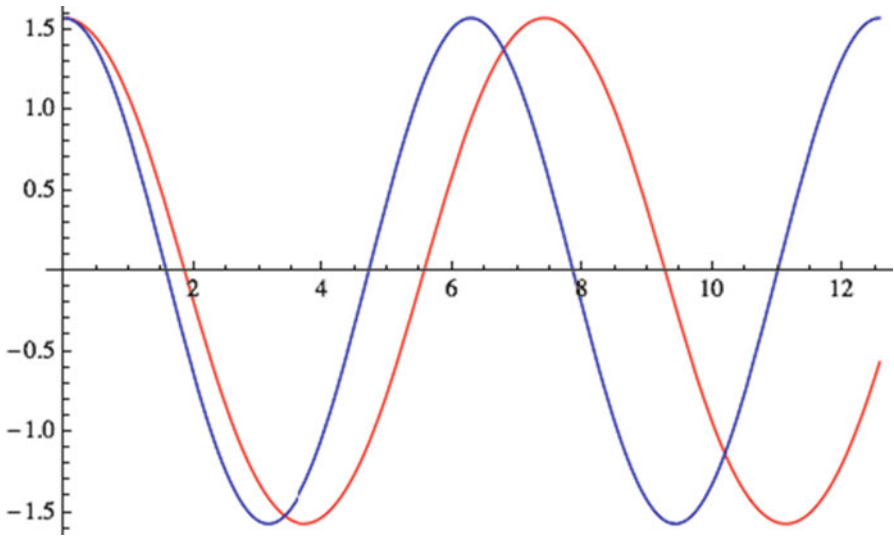

Fig. 2.35 Response of a pendulum started from rest at 90° from vertical

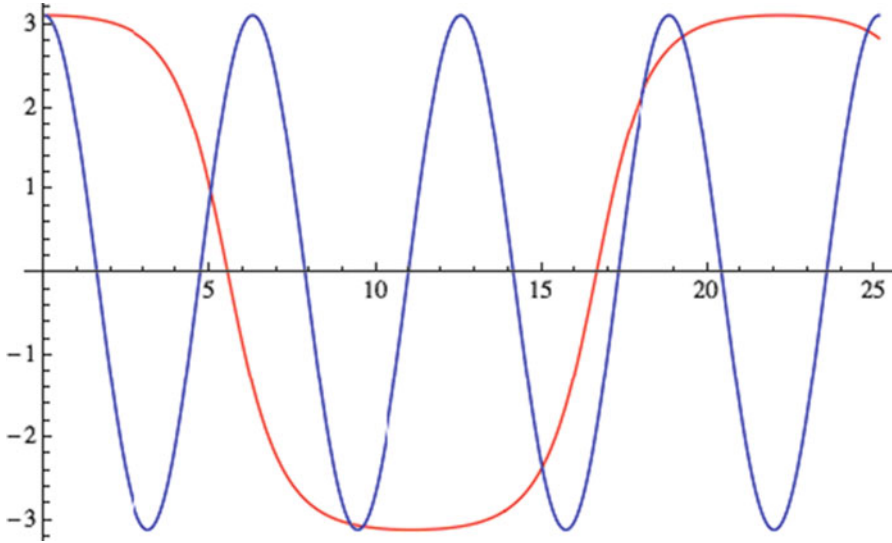

Fig. 2.36 Response of a pendulum started from rest in an almost vertical position

Exercises

1. Verify Eq. (2.2).
2. Solve the following differential equation with its initial conditions

$$\frac{d^2y}{dt^2} + 2y = 0, \quad y(0) = 1, \quad \left. \frac{dy}{dt} \right|_{t=0} = 0$$

3. Solve the following differential equation with its initial conditions

$$\frac{d^2y}{dt^2} + 2y = \sin(t), \quad y(0) = 0, \quad \left. \frac{dy}{dt} \right|_{t=0} = 1$$

4. Find the natural frequency of a pendulum using the energy approach.
5. Find the amplitude and phase of the motion in terms of A and B in Eqs. (2.3) and (2.4).
6. Consider a simple pendulum initially in equilibrium (pointing straight down). What happens when the pendulum bob is struck impulsively in the horizontal direction? Find the maximum angle in terms of the momentum transferred using the linear approximation.
7. Find the equations of motion for a general pendulum for which the rod is not massless. Find the frequency of oscillation in the linear (small θ) limit.

8. Consider the system shown in Fig. 2.8. Write the differential equations from a free body diagram approach. How does gravity enter the problem? What is the difference between gravity and the spring?
9. Find the general solution to the homogeneous damped equation of motion when $\zeta = 1$.
10. Verify the damped impulse response Eq. (2.19).
11. Find the limit of the damped impulse response as $\zeta \rightarrow 1$ from below.
12. Complete the particular solution for an undamped system excited by $a = t^3$.
13. What is the damping ratio for a mass-spring-damper system in which every maximum amplitude is 2 % less than the prior maximum? Suppose that the mass weighs 1 lb and the spring constant is 10 lb/in, what is the value of c (include units)?
14. The deflection of the spring when the system is at rest is half an inch. The mass weighs 20 lbs. The amplitude of a free vibration decreases from 0.4 in to 0.1 in in 20 cycles. What is the damping constant in lb-sec/in?

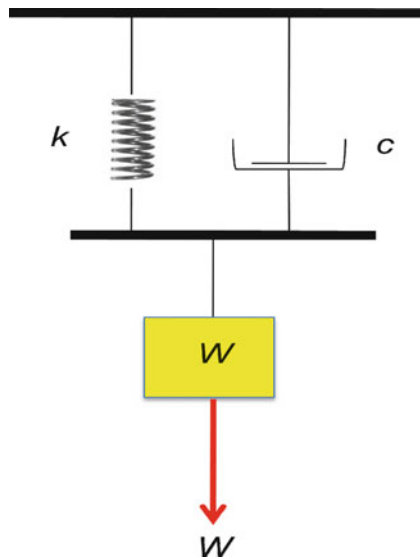

15. A damped vibrating system consists of a spring of $k = 20$ lb/in and a weight of 10 lbs. It is damped so that each maximum amplitude is 99 % of the maximum one full cycle earlier. (a) Find ω_n . (b) Find the damping constant. (c) What amplitude of a force at ω_n will keep the amplitude of oscillation at 1 in?
16. Find an analytic expression for the force on a mass subject to support motion in the absence of damping.

17. Find the effective spring constant for the system shown in the diagram

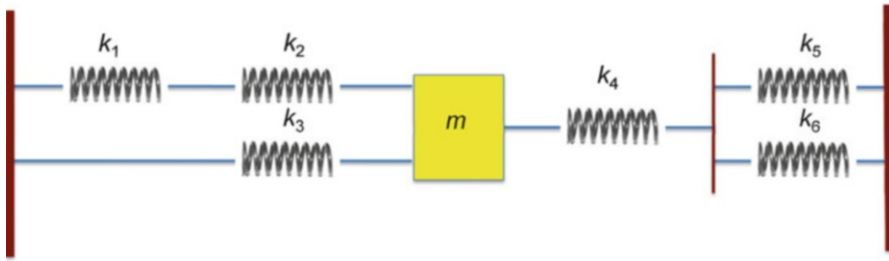

mass-spring system for Ex. 17.

- 18. Show that dampers add in the same way as springs.
- 19. Verify Eqs. (2.18a), (2.18b), and (2.19).
- 20. Apply Eqs. (2.12a) and (2.12b) to the system shown in Fig 2.8.
- 21. A typical speed bump is about two feet wide and two inches high. Suppose it to have a sinusoidal shape and calculate the response of the simple vehicle examined above for various speeds. Do you think that speed bumps would be effective? Discuss.
- 22. Find the response of a damped mass-spring system to support motion, as shown in Figs. 2.18 and 2.19.
- 23. Design a pendulum seismometer with a period of 60 s and a damping ratio of 0.707.
- 24. Draw the block diagram for the linear pendulum.
- 25. Draw a block diagram for the two degree of freedom system

$$m_1\ddot{y}_1 + k(y_1 - y_2) = f_1, \quad m_2\ddot{y}_2 + k(y_2 - y_1) = f_2$$

- 26. Show that the system of Prob. 12 has a solution $y_1 = y_0 + v_0t = y_2$ if $f_1 = 0 = f_2$. Can you construct a physical system that is represented by the two differential equations?
- 27. Draw a block diagram for the air bag sensor.
- 28. Draw a block diagram for the rotating imbalance.
- 29. Find the eigenvalues and eigenvectors for the system shown in Prob. 8.

The following exercises are based on the chapter, but require additional input. Feel free to use the Internet and the library to expand your understanding of the questions and their answers.

- 30. Find the natural frequency of a cantilever beam with a mass at its free end if the mass of the beam can be neglected.
- 31. Consider an inverted pendulum with two springs of constant k on either side, as shown in the figure. The pendulum can move 2° in either direction before coming into contact with the springs. Do not worry about the angles of the springs.

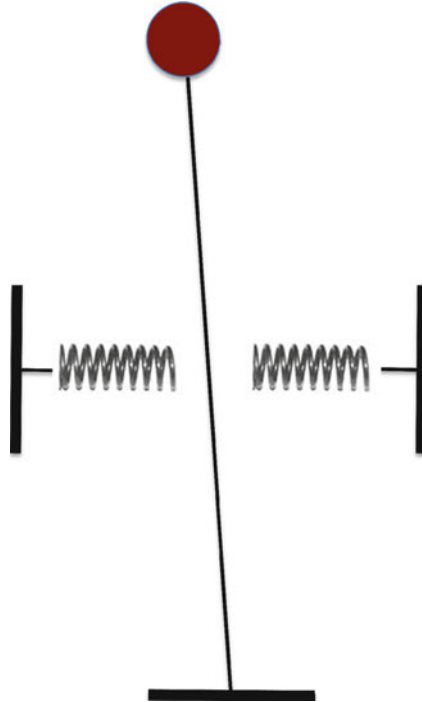

Exercise 31

Set up the equations of motion.

32. The metronome is based on an inverted pendulum with an adjustable position of the bob. How does it work?
33. Why does increasing the damping ratio beyond unity delay the decay of the system?
34. Design an air bag sensor. You will need to learn about how a car crashes.
35. Make a dissipation model for the U-tube of Ex. 2.3 based on fluid viscosity and calculate the behavior of the damped system. Calculate the behavior of the system if the height starts with a 10 % offset. (Choose the viscosity small enough to have an underdamped system.)

References

- Crandall SH, Dahl NC (eds) (1959) An introduction to the mechanics of solids. McGraw-Hill, New York
- Den Hartog JP (1956) Mechanical vibrations. Dover reprint 1985
- Press WH, Teukolsky SA, Vetterling WT, Flannery BP (1992) Numerical recipes in C. The art of scientific computing, 2nd edn. Cambridge University Press, New York



<http://www.springer.com/978-3-319-08370-4>

Mechanical Systems

A Unified Approach to Vibrations and Controls

Gans, R.F.

2015, XVI, 437 p. 62 illus., 38 illus. in color., Hardcover

ISBN: 978-3-319-08370-4