

Generation of Conditional Knockout Mice

Kazuhito Sakamoto, Channabasavaiah B. Gurumurthy,
and Kay-Uwe Wagner

Abstract

Conditional knockout mouse models are powerful tools to examine the biological and molecular function(s) of genes in specific tissues. The general procedure to generate such genetically engineered mouse models consists of three main steps. The first step is to find the appropriate genomic clone of the gene of interest and to design the cloning and Southern blot strategies. The second step is the cloning of the gene-targeting vector with all its essential components including positive and negative selection cassettes and the insertion of *LoxP* sites. Although conventional methods are still being widely used for DNA cloning, we describe in this book chapter the use of λ Red phage-based homologous recombination in *Escherichia coli* to capture the genomic DNA of the gene of interest and to assemble the gene-targeting vector. This new method provides several advantages as it does not require the presence of restriction sites within the gene of interest to insert *LoxP*-flanked DNA fragments. In the final step, the gene-targeting vector is transferred into embryonic stem (ES) cells, and successfully targeted ES cell clones are injected into mouse blastocysts to generate conditional knockout mice.

Key words Conditional knockout, Mouse model, Cre/*LoxP*, Homologous recombination, Subcloning

1 Introduction

Gene targeting techniques and the generation of knockout mouse models are powerful tools for studying the biological and molecular function(s) of genes *in vivo*. Conventional knockout mice, in which critical parts of the genes of interest have been eliminated, were the first models created by relatively simple cloning strategies of the target vector. The vector is electroporated into embryonic ES cells, and the endogenous gene is replaced with the corresponding region of the targeting vector through homologous recombination. These first-generation gene target models provided mechanistic insight into essential functions of a gene during pre- and postnatal development. In about 30 % of cases, however, the conventional deletion of genes causes embryonic lethality. Another shortcoming of conventional knockout mice can be secondary

developmental defects in other organs or tissues that are indirectly affected by a gene deletion. For example, a primary defect in hormone-producing organs such as the pituitary gland or ovary can give rise to secondary phenotypes in effector organs such as the mammary gland. Although some of these primary and secondary phenotypes can be discriminated using a combination of gene deletion and transplant models, advances in BAC recombineering and site-specific recombination technologies such as *Cre/LoxP* and *Flp/Frt* systems have become the standard procedures for the generation of conditional knockout mouse models to study the primary function(s) of genes in specific tissues.

The conditional deletion of the target gene can be achieved by crossing two different mouse strains. One of these strains is the *floxed* mouse line that carries one or two copies of the “floxed” (i.e., flanked by *LoxP* sites) alleles of the gene of interest. The second strain is a transgenic mouse line expressing the site-specific recombinase Cre under a tissue-specific promoter. In the offspring, the gene deletion occurs through site-directed excision of the *floxed* allele within the cells that express Cre recombinase. Since the first report of a conditional knockout by the laboratory of Klaus Rajewsky in 1994 [1], a myriad of strains carrying floxed alleles and transgenic mouse lines that express Cre under tissue-specific promoters have been generated. Many of these lines are available from the Jackson Laboratory (<http://www.jax.org/>) and other repositories such as that of the NCI in Frederick, MD (<http://mouse.ncifcrf.gov/>). Using an interferon-responsive promoter to drive Cre recombinase, the Rajewsky lab also pioneered the development of inducible gene knockouts [2]. Subsequently, Luc St-Onge and Priscilla Furth in the laboratory of Peter Gruss expressed Cre recombinase under the control of a tetracycline (tet)-responsive promoter [3]. In this system, the temporal expression of Cre and excision of the target gene are controlled by the tet-regulated transactivator (tTA or rtTA), which can be expressed ubiquitously or in a cell type-specific manner. Another elegant approach to achieve an inducible and tissue-specific deletion of genes is the use of transgenic lines that express a tamoxifen-dependent Cre recombinase (Cre-ERT2) in selected cell types [4].

Conventional cloning methods are still widely used to generate gene-targeting vectors and conditional knockout mouse models. The availability of suitable restriction enzymes within the locus of interest and the sizes of inserted DNA fragments are common limitations of conventional cloning strategies. A newer method developed in the laboratory of Drs. Copeland and Jenkins [5, 6], which is based on the homologous recombination function of the λ Red phage in *Escherichia coli*, has pioneered the subcloning of large genomic fragments and the generation of targeting vectors. This bacteriophage-based technique allows recombination of homologous sequences as short as 40–50 bp to as large as 10–20 kb.

During the initial design of the targeting vector, this methodology can be used to capture a gene of interest from a genomic bacterial artificial chromosome (BAC) library into a plasmid. This unique feature of the technique does not require the presence of restriction enzyme sites within the gene of interest to insert *LoxP*-flanked DNA segments.

The use of the retrieving plasmid and mini targeting vector construction described in this book chapter is based on the primary reports by Liu et al. [6] and Malureanu [7]. The technical description in this chapter focuses primarily on designing a sub-cloning strategy and methodologies using the λ Red phage system to generate conditional targeting vectors. In addition to the design of vectors containing positive and negative selection markers, the targeting strategy outlined here allows the elimination of the selection cassette (i.e., PGK-neomycin) from the targeted locus in ES cells or mice using Flp recombinase.

2 Materials

2.1 Bacterial Strains

The bacteria strains SW102, SW106, and SW105 [5] are available from Frederick National Laboratory for Cancer Research at National Cancer Institute (<http://web.ncifcrf.gov/research/brb/recombineeringInformation.aspx>). All three bacterial lines are a modified DH10B strain carrying a defective λ phage. They all carry a fully functional galactose operon with a deletion of *galK*, which allows efficient BAC recombineering. SW106 and SW105 cells also contain L-arabinose-inducible Cre or Flp, respectively, which mediate recombination of the *LoxP* or the *Frt* site in the bacteria (Table 1).

2.2 Plasmids

Plasmids PL253, PL452, and PL451 [6] are also available from Fredrick National Laboratory for Cancer Research (Table 2). PL253 is a pBluescript-based plasmid for retrieving the target gene sequences from a BAC clone. This retrieving vector has an *MCI*

Table 1
Bacterial strains for bacteriophage-based recombineering

Strain	Genotype	Antibiotic resistance
SW102	DH10B[λ cl857(<i>cro-bioA</i>)<> <i>tet</i>]	None
SW106	DH10B[λ cl857 (<i>cro-bioA</i>)<> <i>araC-PBADcre</i>]	None
SW105	DH10B[λ cl857 (<i>cro-bioA</i>)<> <i>araC-PBADflpe</i>]	None

Table 2
Plasmids for recombineering

Strain	Genotype	Antibiotic resistance
PL253	Modified <i>MclTK</i>	Ampicillin
PL452	<i>LoxP-Pgk-em7-NeobpA-LoxP</i>	Ampicillin
PL451	<i>Frt-Pgk-em7-NeobpA-Frt-LoxP</i>	Ampicillin

promoter-driven thymidine kinase (*TK*) cassette for use in negative selection of ES cells. PL452 plasmid contains a neomycin (neo) resistance cassette flanked by two *LoxP* sites. PL451 carries a neo cassette flanked by two *Frt* sites and one *LoxP* site. Neo genes in both of the plasmids are driven from a prokaryotic promoter (*em7*) and a eukaryotic promoter (*Pgk*) (*see Note 1*). pBluescript (pSK⁺) is utilized for cloning of *LoxP* sites carrying homologous regions of the target gene as a mini targeting vector.

2.3 Bacterial Artificial Chromosomes

A targeted gene sequence is inserted into the retrieving vector, PL253, from a BAC clone. BAC libraries generated from AB2.2 ES cell DNA (129S7 mouse strain) are available from BioScience [8]. BAC libraries from the C57BL/6 mouse strain can be obtained from the BACPAC resources center at Children's Hospital Oakland Research Institute (<http://bacpac.chori.org/>). For efficient gene targeting, it is recommended to use isogenic DNA, i.e., genomic clones from a BAC library that are genetically identical or similar to the ES cells.

2.4 Reagents Needed

1. Restriction enzymes (New England Biolabs).
2. Miniprep, Gel extraction, and Maxiprep kits (Qiagen).
3. GoTaq[®] DNA Polymerase (Promega).
4. TOPO[®] TA Cloning kit (Invitrogen) (optional; to clone Southern probe).
5. Random Primed DNA labeling kit (Roche).
6. DNA Denaturizing and Neutralizing solution (Quality Bio).
7. dCTP (alpha ³²P) (Perkin Elmer).
8. QuikHyb (Agilent technologies).
9. GeneScreen Plus[®] Hybridization Transfer Membrane (Perkin Elmer).
10. DH5 α [™] Competent cells (Invitrogen).
11. L(+) Arabinose (Sigma).
12. Expand Long Range PCR, dNTPack (Roche).

3 Methods

3.1 Designing of Cloning and Southern Blot

The first step in generating conditional knockout mice is to design the cloning and Southern blot strategies and to find appropriate BAC clones. In order to choose the most critical exon(s) for deletion, there are many considerations such as intron-exon spacing, presence of exons of other genes in the opposite strand, and protein domain. These issues have been described in detail elsewhere [9–11] and are not being discussed here. There are many online resources for searching the sequence of your target gene and BAC clones. For demonstration purposes, the Ensemble website was used to find the BAC clone that contains the sequence from the gene of interest. The probe for the Southern blot was tested using mouse genomic and BAC DNA.

3.1.1 Designing of Cloning and Southern Blot Strategy

1. Go to the Ensembl website (<http://www.ensembl.org/index.html>).
2. Access “Mouse” in the genome section and search for the gene of interest.
3. Select the appropriate gene when the list appears.
4. Click “Sequence” in the Gene tab to download the sequence of the target gene.
5. The exon details can be found by clicking on “Exons” in Transcript tab.
6. Draw a strategy map of the targeted gene. Locate where the *LoxP* sites should be inserted, and where the probe should bind and identify restriction enzyme sites for Southern blot analysis as represented in Fig. 1 (*see Note 2*).

3.1.2 Selecting BAC Clones Across a Desired Gene Locus

1. In the Ensemble website (<http://www.ensembl.org/index.html>), access “Mouse” in the genome section and search for the gene of interest.
2. Select the appropriate gene when the list appears and open “Location.”
3. Click “Configure this page,” “Custom Data” tab, and then “Attach DAS,” to select BAC clones.
4. Go to “Configure Region Image” tab and click “Sequence and Assembly,” and then “Clones.”
5. “Enable” the option for mouse BAC clones and close the panel to accept the changes.
6. A Contig map and list of BAC clones should appear.
7. Select the BAC clones that cover the targeted gene.

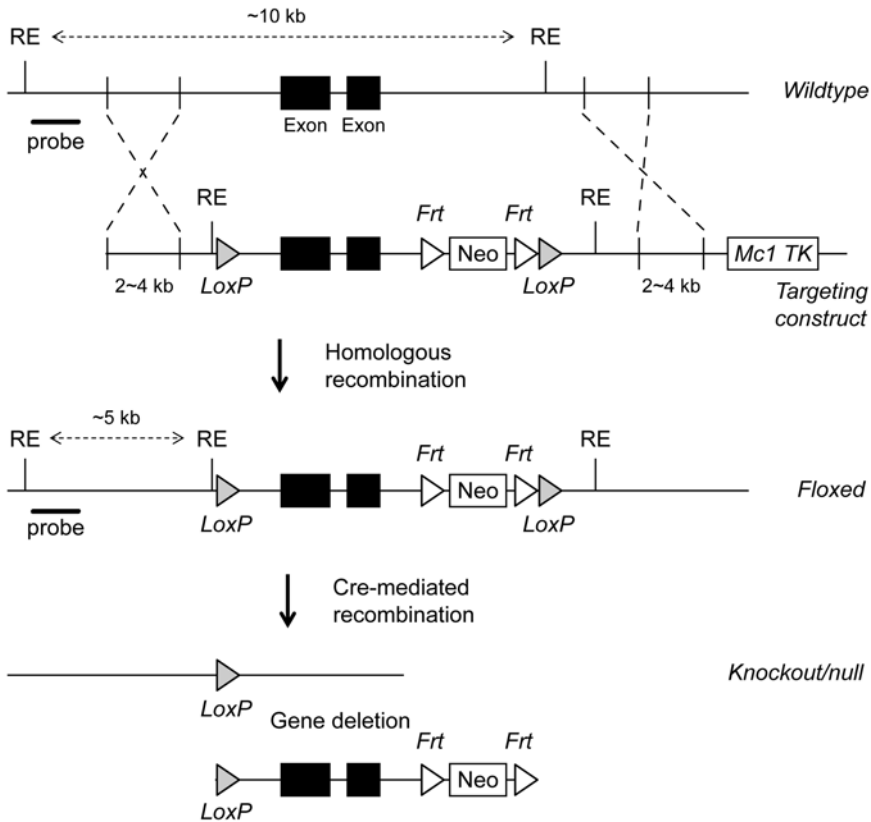

Fig. 1 Gene targeting and generation of a conditional knockout (*floxed*) allele of the gene of interest. Targeting strategy to flank the exons of the gene of interest with *LoxP* sites. The probe for Southern blot analysis is designed to be between 400 and 800 bp. RE indicates appropriate restriction enzyme sites that cover the exons being flanked by *LoxP* sites. It is recommended to choose the RE that creates a DNA digest of about 10 kb in size for the *wild-type* and about 5 kb for the *floxed* allele. The targeting vector is constructed by placing a PGK-neo selectable marker flanked by *Frt* sites. The RE in the 5' end of the first *LoxP* site can be generated in the later process. Cre recombination deletes the exons that are flanked by the *LoxP* sites

3.1.3 Mini-Prep of BAC Clone

1. Culture a BAC clone in 5 ml of LB media containing the appropriate antibiotic at 37 °C and agitate at ~225 rpm overnight (*see Note 3*).
2. Centrifuge the cultured bacterial cells at 6,000 × *g* for 1 min.
3. Resuspend the pelleted cells with 250 μl Buffer P1 from the Qiagen Miniprep kit, then add 250 μl Buffer P2, and invert thoroughly. Mix 350 μl Buffer N3 and mix by inverting. Centrifuge at >13,000 × *g* for 10 min and collect supernatant.
4. Add 750 μl isopropanol, mix by inverting, and incubate at room temperature for 10 min (*see Note 4*). Centrifuge at >13,000 × *g* for 10 min to precipitate the BAC DNA, wash with 70 % ethanol, allow to dry until ethanol has evaporated, and then reconstitute with 100 μl TE (pH 8.0). DNA concentration should be around 1 μg/μl.

**3.1.4 Designing Probes
and Southern Blot Analysis
Using Mouse Genomic
and BAC DNA**

1. Design ~20–30 bp primers to amplify ~400–800 bp of probe for Southern blot (*see* Fig. 1).
2. Perform PCR on BAC DNA with the primers using a Taq polymerase. Extract the PCR product from an agarose gel using the Gel Extraction kit and clone into the TA vector following the instructions from the TOPO® TA Cloning kit. Analyze the sequence of the probe using M13 forward and reverse primers. The probe can be isolated from the TA vector with EcoRI or the appropriate restriction enzyme (*see* Note 5). Alternatively, a PCR product generated using BAC DNA can be used as a probe after gel purification (instead of cloning into TA vector).
3. To test whether the probe works in a Southern blot assay, digest 10–15 µg of genomic DNA from a wild-type mouse or ES cell DNA (preferably from the strain that will be used for targeting) with the appropriate restriction enzymes (*see* Note 6). To use as a control, digest ~1 µg of the BAC DNA and dilute the digested BAC DNA to obtain equimolar concentration with genomic DNA. A control lane on the Southern blot using the digested BAC DNA should serve as an ideal positive control.
4. Run the restriction digested DNA on a 0.7 % agarose gel, denature the DNA in the gel using denaturing solution, neutralize the DNA with neutralizing solution, and then transfer the DNA onto a charged nylon membrane.
5. Fix the DNA to the blot by UV-cross-linking.
6. Label the probe with ³²P following the instructions from a Random Primed DNA labeling kit.
7. Pre-hybridize the blot with a hybridization buffer such as Agilent's QuikHyb at 68 °C in a hybridization oven for at least 1 h.
8. Add the probe directly to the hybridized buffer and incubate at 65 °C overnight.
9. Wash the membranes with 2×, 1×, and 0.5× SSC buffer containing 0.1 % SDS for 30 min each and check the radiation level after each washing. If the level is too strong after the 2× wash, then wash with 1×, then 0.5×, and so on until the level is around 0.5 mR/h.
10. Expose the blot to X-ray film at –80 °C for 48–72 h.

**3.2 Construction
of the Targeting Vector**

The first step is to transfer the genomic region of interest (includes left and right homology arms) from the BAC DNA into the retrieving vector PL253 that carries an *Mcl* promoter-driven thymidine kinase (*TK*) cassette used for negative selection of the ES cells (Fig. 2). Next, in the retrieving vector, the first *LoxP* sequences

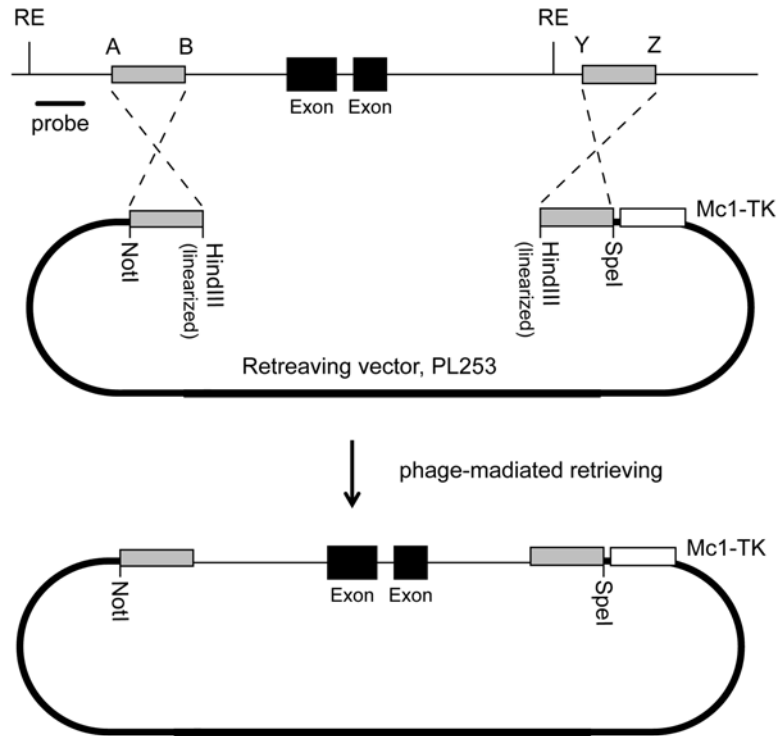

Fig. 2 Subcloning the fragment of the gene of interest from a BAC into the PL253 *MCL-TK*-containing retrieving vector by λ phage-based homologous recombination. The two homologous arms (gray boxes) are amplified from the BAC DNA using the primers A/B and Y/Z, and cloned into PL253. The plasmid is linearized with HindIII and to induce recombination with the BAC DNA

are inserted into the appropriate area and the neomycin selection cassette is removed by arabinose-mediated Cre recombination after positive selection. Then, the second *LoxP* site is transferred into the targeting gene (Fig. 3). The λ phage-based recombination is utilized for these cloning steps.

3.2.1 Subcloning the Genomic Region from the BAC into a Retrieving Vector

To begin the subcloning process, the homologous regions from both the 5' and 3' ends of the target gene in the BAC plasmid are amplified by PCR and these PCR fragments are cloned into the retrieving vector PL253 (Fig. 2). Both the BAC plasmid and the vector are electroporated into SW102 competent cells where the PL253 captures the target gene by λ phage-based recombination.

1. Select 200–500 bp regions at the 5' and 3' ends of the target gene for homologous recombination into the PL253 retrieving vector. Design PCR primers that not only amplify the homologous regions but also add specific restriction sites that are utilized for inserting homologous recombination arms into the retrieving vector. Table 3 shows which restriction enzymes can be included with specific primers (see Note 7).

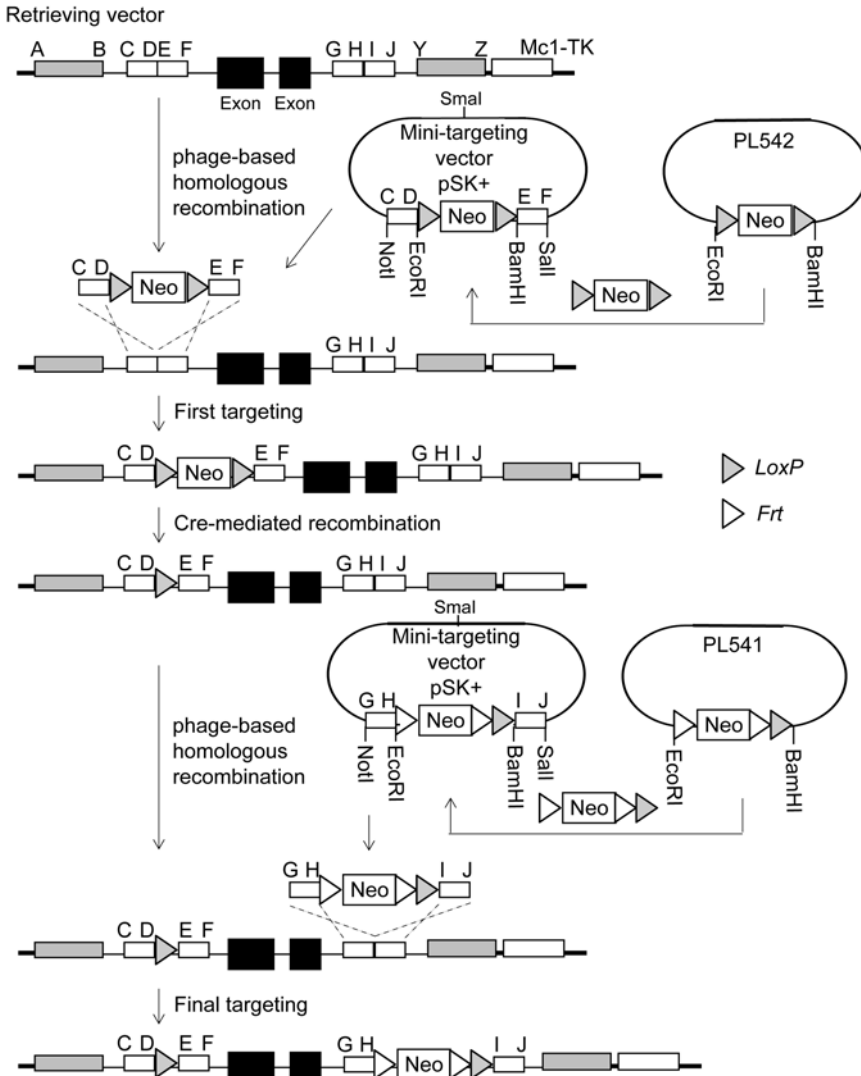

Fig. 3 Constructing a conditional knockout allele. The mini targeting vector is constructed by ligation with two homologous arms amplified from the BAC DNA and a floxed neomycin resistance cassette (*gray arrows: LoxP* site). The retrieving vector and the excised targeting cassette are recombined in the competent cells, SW106. Then, the neo cassette, flanked by *LoxP* sites, is deleted by arabinose-induced Cre recombinase. The second *LoxP* site is inserted as well as the first site

2. Perform PCR of the BAC plasmid (Subheading 3.1.3) with primers A/B and Y/Z, and digest the appropriate PCR products with either *Not*I or *Spe*I and *Hind*III restriction enzymes. These fragments (AB and YZ) are ligated using T4 DNA ligase into the PL253 that has been linearized with *Not*I and *Spe*I and gel purified.
3. Transform the ligation mixture into DH5 α cells and culture the cells on an LB plate that contains ampicillin (100 μ g/ml).

Table 3
Unique restriction enzyme sites contained in the primers for homologous recombination arms

Primer	Restriction enzymes
A	NotI
B	HindIII
Y	HindIII
Z	SpeI

4. To confirm the insertion of homologous arms with correct orientation, perform a colony PCR with the following primer sets: M13 forward primer B, primer A/primer Z, and primer Y/M13 reverse primer. Additionally, the entire insert sequence can be analyzed by utilizing the M13 forward and reverse primers. Next, linearize the retrieving vector with HindIII and gel purify.
5. Transform the original BAC clone into the recombinant bacterial strain, SW102. Next, culture the cells in 5 ml LB media at 32 °C overnight. The next day, transfer 1 ml of the culture into 10 ml of LB media and culture for a few hours until the cell density reaches an OD₆₀₀ of 0.6. Collect the competent cells by spinning at 1,800 × g and wash with cold water (4 °C) three times. Resuspend the cell pellet with 100 µl of water and mix with 5–15 ng of BAC plasmid. The BAC DNA should then be electroporated into the cells in a precooled electroporation cuvette (0.1 cm gap) under the following condition: 1.75 Kv, 25 µF with the pulse controller set at 200 Ω. The cells are then cultured in 1 ml of SOC media for 1 h, and spread (1–100 µl) onto LB plates containing 12.5 µg/ml chloramphenicol. Incubate plates at 32 °C overnight. The bacterial colonies should carry the BAC clone.
6. Pick a colony from the plate and culture in LB media until the cell density reaches an OD₆₀₀ as described above. To activate the λ Red system, heat-shock the 10 ml of the bacterial culture in a shaking water bath at 42 °C for 15 min. Allow the cells to cool down on ice and wash with 4 °C water. Electroporate the HindIII linearized retrieving vector (5–15 ng) that was obtained in **step 4** of this section into the competent cells as described above. After culturing the cells for 1 h in SOC media, spread the cells on an LB plate containing ampicillin and incubate at 32 °C overnight. Most of the colonies should contain the PL253 vector that retrieved the target gene. Non-heat-shocked bacteria would be a good negative control for the λ phage-based recombination (*see Note 8*).

7. To eliminate unrecombined plasmids, purify the DNA from the bacteria, transform it into DH5 α cells, and select with ampicillin. The positive cells are confirmed by colony PCR and through unique restriction enzyme digestion. Once the positive cells are confirmed, purify the retrieving vector for use in Subheading 3.2.2, step 3.

3.2.2 Insertion of *LoxP* Sites into the Targeting Vector

This section discusses the insertion of the *LoxP* sites into the targeting vector (Fig. 3). The *LoxP* sites are first cloned into pBlue-script surrounded by about 300 bp of homologous sequence from the original BAC clone; these constructs are called mini targeting vectors. The first *LoxP* site containing the *LoxP-neo-LoxP* sequence is inserted into the retrieving vector, using the λ phage-based recombination system. The neomycin resistance cassette is then removed by Cre recombination in the SW106 competent bacteria, which have a functional arabinose-inducible Cre recombinase. After removing the neomycin cassette, the second *LoxP* site, comprising the *Frt-neo-Frt-LoxP* sequence, is subsequently inserted into the retrieving vector.

1. To subclone the mini targeting vectors, homologous recombination sequences first need to be amplified from the original BAC clone. Design primers that will amplify about 300 bp from both the 5' and 3' regions around the proposed *LoxP* site. Similar to Subheading 3.2.1, step 1, these primers should contain unique restriction enzyme sites at the 5' end as described in Table 4. Include a restriction enzyme site in primer D that is utilized in Subheading 3.1.4, step 3, to aid in Southern blot analysis (*see* Note 9). The PCR products are then digested with the appropriate restriction enzymes and purified using a gel extraction kit.
2. To release the *LoxP-Neo-LoxP* or the *Frt-Neo-Frt-LoxP* cassettes, plasmids PL452 (first *LoxP*) and PL451 (second *LoxP*) are digested with EcoRI and BamHI restriction enzymes.

Table 4
Unique restriction enzyme sites in the primers for the mini targeting vectors

Primer	Restriction enzymes
C, G	NotI
D, H	EcoRI
E, I	BamHI
F, J	SalI

The purified PCR fragments and the corresponding digested *LoxP* site are inserted with T4 DNA ligase into NotI- and SalI-digested pBluescript. After transformation of the ligation products into DH5 α cells, the orientation of the mini targeting vectors should be confirmed by colony PCR and restriction enzyme digestions. The *LoxP*/homologous arm fragment is released from the mini targeting vector using NotI, SalI, and SmaI (*see Note 10*); gel purify the fragment using a gel extraction kit.

3. Transform the retrieving vector (Subheading 3.2.1, step 7) into SW106 electro-competent cells as described in Subheading 3.2.1, step 5. Culture 10 ml of the transformed competent cells (*see* Subheading 3.2.1, step 5) until the cell density reaches an OD₆₀₀ as described in Subheading 3.2.1, step 5. To activate the λ Red system, heat-shock 10 ml of the bacterial culture in a shaking water bath at 42 °C for 15 min. Cool the cells on ice and wash them with cold water. Mix 1 ng of the fragment containing the first *LoxP* (*LoxP-Neo-LoxP*) cassette with the competent cell suspension. Perform electroporation using an electroporation cuvette as described above. After culturing the cells for 1 h in SOC media, spread the cells on an LB plate containing ampicillin and kanamycin (100 μ g/ml and 40 μ g/ml, respectively) and incubate at 32 °C overnight. The positive cells that grow should contain both ampicillin and kanamycin resistance genes from the retrieving vector and the *LoxP* insert. Non-heat-shocked bacteria would be a negative control for the λ phage-based recombination since it does not carry kanamycin resistance. The recombination can be confirmed with colony PCR using primer sets that start outside of the recombination arms and go into the *P_{gk-em7-Neo}* sequence. To eliminate unrecombined DNA in the cells, transform the purified vector into DH5 α cells and culture on an LB plate containing both ampicillin and kanamycin (*see* Subheading 3.2.1, step 7).
4. To remove the neomycin resistance cassette, culture SW106 competent cells until the cell density reaches an OD₆₀₀. Add 100 μ l of 10 % L(+) arabinose into 10 ml of the culture (final concentration, 0.1 %) and culture at 32 °C for 1 h. After washing the cells with cold water, the vector carrying the first *LoxP* site is transformed into the cells by electroporation. The cells are cultured for 1 h in SOC media and spread on both ampicillin and kanamycin plates (*see Note 11*). After overnight incubation at 32 °C, there should be colonies only on ampicillin plates. Perform PCR using primers C and F on the bacterial colonies to confirm that the neomycin resistance cassette is deleted by arabinose-mediated Cre recombination.

5. The last step for the subcloning is inserting the second *LoxP* site. Either of the competent cells, SW106 or SW105, can be used to introduce the *LoxP* site into the subcloning vector following the protocol in Subheading 3.2.2, step 5. SW105 cells have an *Flpe* gene under the control of arabinose to delete the neomycin resistance cassette. Note that an *Flpe*-induced recombination is not required in this protocol, but it is important to analyze the sequence within the region that has been modified in this final construct.

3.3 Gene Targeting in ES Cells

The subcloned vector is linearized at its 5' end using *NotI* or appropriate restriction enzyme and electroporated into ES cell lines. ES cells from mouse strain 129 were used in this subcloning process since the BAC clones were generated from AB2.2 ES cells [8]. The transformed cells are selected with G418 (200 µg/ml) to screen for neomycin-resistant colonies. The gene targeting into mouse ES cells is described in detail elsewhere [12]. The selected colonies are confirmed for homologous recombination by long-range PCR on both sides in which one primer is outside of the homologous arm and the other binds to the targeting cassette near respective *LoxP* site. Then, the PCR-positive colonies are further analyzed by Southern blot as described previously. The targeted ES cells should show a large-size band as the *wild-type* allele and a small-size band as a conditional knockout (*floxed*) allele.

3.4 Blastocyst Injection and Germline Transmission

The targeted ES cells are injected into the blastocoel of 3.5-day-old mouse blastocysts. For this purpose, host embryos are chosen that can be distinguished from the coat color contribution from the ES cells. For example, C57BL/6 embryo (black) donors are injected with 129 ES cells (agouti). Currently black and albino B6 ES cells have been established that offer a wide variety of choices so that the mutants generated can be under a pure genetic background. The injected embryos are surgically transplanted into the uterine horns of recipient females. If the injected ES cells become part of growing embryos, the offspring will have typical chimeric patches of coat color derived from host embryos and the ES cells. The chimeric mice are crossed with wild-type mice to determine germline transmission, i.e., whether the mutation in ES cells transmits to the offspring. This is characteristic of pups that exhibit the coat color from the ES cells. For example, germline offspring exhibit an agouti coat color, which is derived from agouti 129 ES cells, and black pups are derived from blastocysts of C57BL/6 host. The germline mutation mice carry a heterozygous *floxed* allele. These F1 mice must be crossed to each other to yield homozygous mice. If the neomycin resistance cassette causes embryonic lethality in the homozygous state, then the neomycin cassette can be deleted in the germline of transgenic mice expressing *Flp* recombinase (see Jackson Laboratory for availability of strains in the desired genetic background).

4 Notes

1. *PGK* permits expression of the neomycin resistance cassette in mammalian cells, whereas *Em7* allows for expression of the cassette in bacterial cells.
2. In this schematic, the expected size of the genomic region captured from a BAC clone to a targeting vector should be around 10 kb and homologous recombination arms in both 5' and 3' prime ends should be 2–4 kb each. These sizes will allow for high-efficiency homologous recombination from targeted vector in mouse ES cells.
3. The bacterial cells can be stored in LB media containing 10 % glycerol at -80°C .
4. Plasmids >50 kb, such as BACs, elute less efficiency from silica than smaller plasmids. Therefore, precipitation of DNA using isopropanol instead of using the columns from the Miniprep kit is suggested.
5. The sequence of the multi-cloning site on the TA vector that captures the probe can be found on the Invitrogen website (<http://www.invitrogen.com>).
6. It is ideal to choose restriction enzymes for Southern blot analysis that can generate about 10–15 kb fragment of your gene of interest, labeled in the figure as the *wild-type* (10 kb) allele. These restriction enzymes can be engineered into the homologous arms for the first *LoxP* site and are utilized in Subheading 3.2.2, **step 1**, to create a smaller fragment (~5 kb) labeled as the *conditional knockout* allele.
7. An additional 3–4 random nucleotides should be added at the 5' termini of the primers to help in the restriction enzyme digestion of the PCR products. Each primer should contain the random nucleotides, the restriction enzymes, and then 20–25 sequence-specific nucleotides from the 5' end.
8. There should be at least ten times less non-heat-shocked colonies than colonies that have been heat-shocked.
9. The appropriate restriction enzyme site should be incorporated in between *EcoRI* and the actual primer sequences recognizing the targeted gene.
10. The *LoxP* site with homologous arms is almost the same size as the mini targeting vector backbone (about 2 kb each). There is a *SmaI* restriction site in the middle of the vector backbone that can be used to create smaller fragments to more easily separate the *LoxP* part from the vector backbone on the gel.

11. The cells that have deleted the neomycin resistance cassette should lose kanamycin resistance. Therefore, the kanamycin plate would be used as a negative control for the recombination.

References

1. Gu H, Marth JD, Orban PC, Mossmann H, Rajewsky K (1994) Deletion of a DNA polymerase beta gene segment in T cells using cell type-specific gene targeting. *Science* 265:103–106
2. Kuhn R, Schwenk F, Aguett M, Rajewsky K (1995) Inducible gene targeting in mice. *Science* 269:1427–1429
3. St-Onge L, Furth PA, Gruss P (1996) Temporal control of the Cre recombinase in transgenic mice by a tetracycline responsive promoter. *Nucleic Acids Res* 24:3875–3877
4. Anwar AR, Smithers SR, Kay AB (1979) Killing of schistosomes of *Schistosoma mansoni* coated with antibody and/or complement by human leukocytes in vitro: requirement for complement in preferential killing by eosinophils. *J Immunol* 122:628–637
5. Warming S, Costantino N, Court DL, Jenkins NA, Copeland NG (2005) Simple and highly efficient BAC recombineering using galK selection. *Nucleic Acids Res* 33:e36
6. Liu P, Jenkins NA, Copeland NG (2003) A highly efficient recombineering-based method for generating conditional knockout mutations. *Genome Res* 13:476–484
7. Malureanu L (2011) Targeting vector construction through recombineering. In: Deursen J, Hofker MH (eds) *Transgenic mouse methods and protocols*. Humana Press, Totowa, NJ, pp 181–203
8. Adams DJ, Quail MA, Cox T et al (2005) A genome-wide, end-sequenced 129Sv BAC library resource for targeting vector construction. *Genomics* 86:753–758
9. Wu S, Ying G, Wu Q, Capecchi MR (2008) A protocol for constructing gene targeting vectors: generating knockout mice for the cadherin family and beyond. *Nat Protoc* 3:1056–1076
10. LePage DF, Conlon RA (2006) Animal models for disease: knockout, knock-in, and conditional mutant mice. *Methods Mol Med* 129:41–67
11. Lee SC, Liu P. (2009) Construction of gene-targeting vectors by recombineering. *Cold Spring Harbor Protocols* 2009: db
12. Southon E, Tessarollo L (2009) Manipulating mouse embryonic stem cells. *Methods Mol Biol* 530:165–185



<http://www.springer.com/978-1-4939-1214-8>

Mouse Genetics

Methods and Protocols

Singh, S.R.; Coppola, V. (Eds.)

2014, XIV, 475 p. 92 illus., 68 illus. in color., Hardcover

ISBN: 978-1-4939-1214-8

A product of Humana Press