

# Molecular spectroscopy in the ultraviolet and visible range

## Contents

- 1 The spectrum of electromagnetic radiation
- 2 The origin of UV/VIS spectra
- 3 The Beer-Lambert law
- 4 Design of UV/VIS spectrophotometers
  - 4.1 Light sources used in UV/VIS spectroscopy
  - 4.2 Monochromator
  - 4.3 Sample chamber
  - 4.4 Detector and data system
- 5 Types of UV/VIS spectrophotometers
- 6 Sample handling and measurement
  - 6.1 Cells (cuvettes)
  - 6.2 Solvents
  - 6.3 Effect of solvent, pH and temperature
- 7 Spectrometric methods in the collection
- 8 References

## 1 The spectrum of electromagnetic radiation

The spectrum of electromagnetic radiation as a whole spans the range of wavelengths ( $\lambda$ ) from  $10^{10}$  m (infrasound) down to  $10^{-14}$  m (cosmic radiation). Ultraviolet (UV) and visible (VIS) radiation comprise only a small portion of wavelengths from about  $10^{-6}$  to  $10^{-7}$  m (see Fig. 1).

For all types of electromagnetic radiation, the associated energy ( $E$ ) is calculated using Planck's constant:

$$E = h \times \nu \quad (1)$$

- $E$  Energy  
 $h$  Planck's constant ( $9.626 \times 10^{-34}$  J s<sup>-1</sup>)  
 $\nu$  Frequency in s<sup>-1</sup>

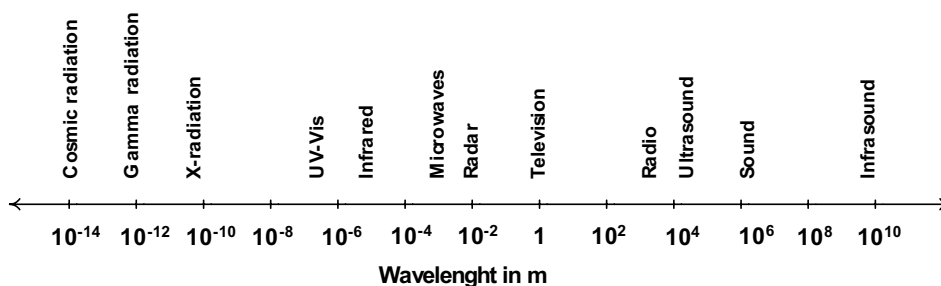

Fig. 1. The complete spectrum of electromagnetic radiation.

The frequency of the radiation is calculated according to the following equation:

$$\nu = \frac{c}{\lambda} \quad (2)$$

$c$  Velocity of light ( $3 \times 10^8 \text{ m s}^{-1}$ )

$\lambda$  Wavelength in m

In UV/VIS spectroscopy, wavelengths are usually expressed in nanometers ( $\text{nm} = 10^{-9} \text{ m}$ ). The presumably best-known example is the yellow colour of the sodium flame, which is due to the 589.5 and 589.0 nm double line of wavelengths.

Equations (1) and (2) also readily show that radiation energy increases with shorter wavelengths. Hence, UV radiation contains more energy than does visible light.

## 2 The origin of UV/VIS Spectra

UV/VIS spectra originate from the excitation of electrons, and therefore UV/VIS spectroscopy is often also referred to as “electron spectroscopy”. The term “electron spectroscopy” encompasses the excitation of electrons by ultraviolet or visible radiation. Hence UV/VIS spectra belong to the molecular spectra.

The total energy of a molecule is represented as the sum of its translational, rotational, vibrational and electronic energies.

$$E_{\text{total}} = E_{\text{translational}} + E_{\text{rotational}} + E_{\text{vibrational}} + E_{\text{electronic}} \quad (3)$$

The various forms of energy differ with regard to the amount of energy they contain; within a molecule the order is:

$$E_{\text{electronic}} > E_{\text{vibrational}} > E_{\text{rotational}} > E_{\text{translational}}$$

In molecules or atoms whose electrons are excited by UV/VIS radiation, transitions take place between the various energy levels of the electrons, the individual excitation

wavelengths being determined by the distribution of electrons in the molecule or atom. In the ground-state molecule, the electrons will normally be in a bonding singlet state. However, when an electron is excited it changes to an antibonding singlet state. Such a change is associated with a transition, as a rule at room temperature, from the vibrational ground state of the electronic ground state to an excited vibrational state of the excited electronic state (Franck-Condon Principle, see Fig. 2).

When the energy of the incident light corresponds to the energy of transition between two electronic states this results in excitation and, hence, transition of the electron from the highest occupied molecular orbital (HOMO) to the lowest unoccupied molecular orbital (LUMO). The energy that this requires is withdrawn from the incident light, and this process is referred to as absorption.

In diatomic molecules such as the hydrogen molecule  $H_2$ , this transition is fairly easily described. In polyatomic molecules, however, description of the transitions is limited to the electrons in transition.

Saturated organic molecules, for example the alkanes, require considerable excitation energy so that transition takes place only in the far UV (approx. 160 nm). As a consequence, the compounds are colourless.

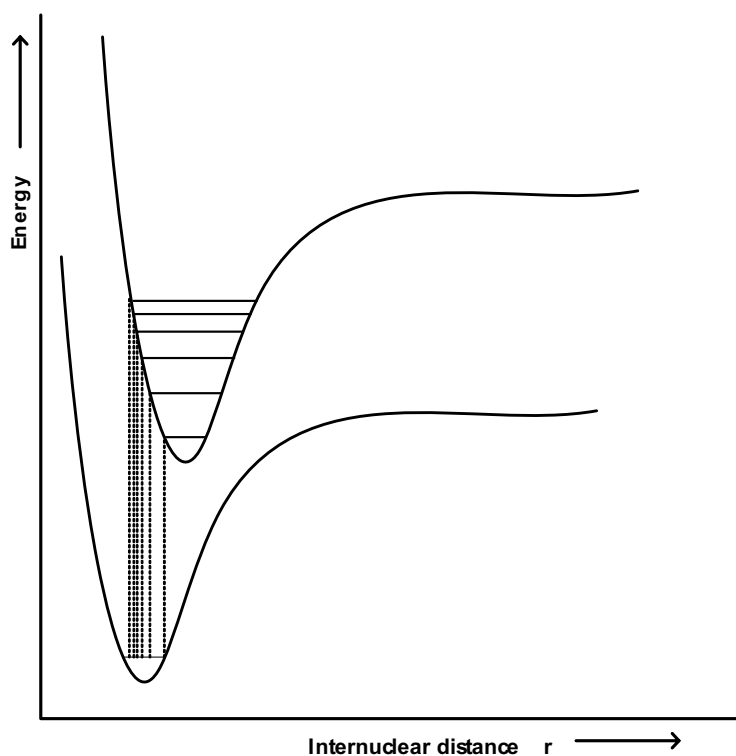

**Fig. 2.** Schematic representation of the energy of the electronic ground state and a stable excited state in a diatomic molecule with a number of transitions.

Many molecules have electronic configurations with bonding and nonbonding electrons which are more readily excitable at optical wavelengths. Carbonyl compounds, for instance, possess bonding  $\pi$  electrons ( $C=O$ ) as well as nonbonding  $n$  electrons at the oxygen atom. Both bonding and nonbonding electrons can be excited but will, of course, absorb at different wavelengths.

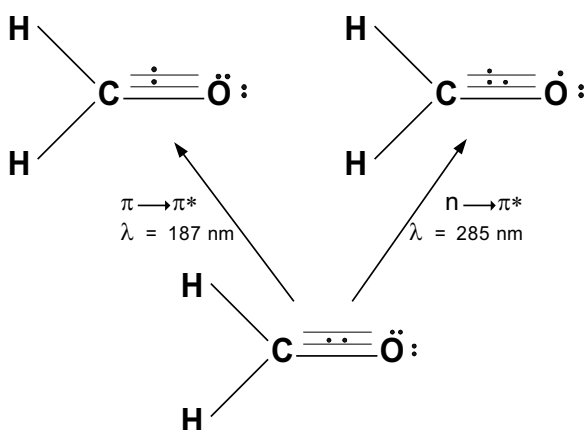

**Fig. 3.** UV/VIS-active transitions of the carbonyl group, as exemplified by formaldehyde.

When viewing UV/VIS spectra one notices that the bands are usually quite broad. This is caused by the numerous vibrational and rotational states corresponding to the ground state and the excited states. It is not the case that one transition occurs from a particular energy level to another. Rather, there are different possible transitions that can lead to various vibrational and rotational states, thus resulting in the broadening of the bands. In addition, there are numerous other effects that lead to a broadening of the bands. For instance, when UV/VIS spectra are recorded in solution, the solvent plays a crucial role in broadening and shifting bands (cf. Section 6.3).

Absorption in the visible range results in colour if the incident light is white. However, the perceivable colour, e.g. of a solution, is not the colour of the light which is absorbed but its complementary colour. For example, if the solution turns red, bluish green light is absorbed. In the case of yellow-coloured solutions, blue light absorbed, whilst blue solutions absorb red to orange light.

### 3 The Beer-Lambert law

The basic principles that can be used to quantify light absorption in solutions were recognised early. In the 18th century, Lambert and Bouguer found that, at a constant concentration, differential light absorption was proportional to path length. The combina-

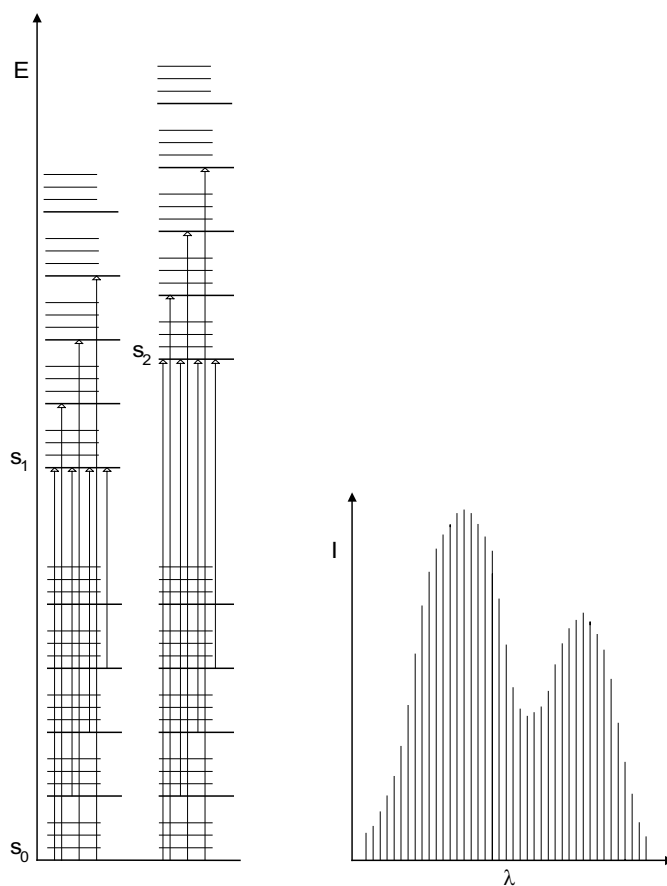

**Fig. 4.** Electronic transitions in molecules and UV/VIS spectra as the result of electronic, vibrational and rotational transitions.

tion of that law with Beer's law, which states that light absorption in a coloured solution is proportional to the concentration of the substance dissolved in a colourless solvent, leads to what is known as the Beer-Lambert law.

$$T = \frac{I}{I_0} = e^{-\varepsilon_\lambda cd} \quad (4)$$

- $T$  Transmittance
- $I$  Intensity of transmitted light
- $I_0$  Intensity of incident light
- $\varepsilon_\lambda$  Extinction coefficient at a given wavelength
- $c$  Concentration
- $d$  Path length

The Beer-Lambert law is best known in its logarithmic form:

$$E_{\lambda} = -\log T = -\log \frac{I}{I_0} = \log \frac{I_0}{I} = \varepsilon_{\lambda} \times c \times d \quad (5)$$

$E_{\lambda}$  Extinction at a given wavelength

This linear form of the Beer-Lambert law is used in numerous analytical methods. As a rule, extinction is then plotted against concentration. The extinction coefficient is a characteristic of a particular substance under given conditions (wavelength, solvent and temperature). This would allow the extinction of a solution to be calculated for a specific set of conditions. However, in UV/VIS spectrometry, separate calibration curves are used in order to preclude instrument-specific effects (Fig. 5).

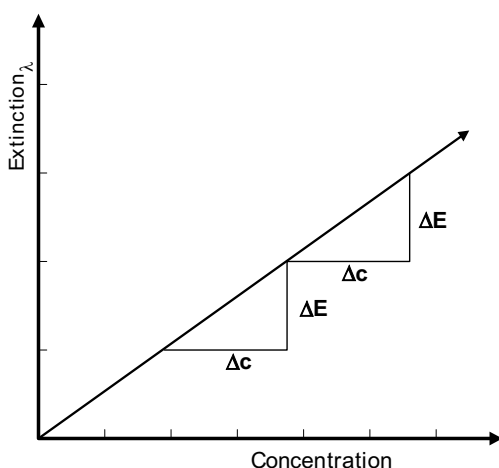

Fig. 5. Graphical representation of the Beer-Lambert law.

#### 4 Design of UV/VIS spectrophotometers

A UV/VIS spectrophotometer is an instrument designed to measure the transmittance or absorbance of a sample as a function of the wavelength of the incident light. All spectrophotometers contain five basic components:

- ⇒ Light source (radiation source)
- ⇒ Monochromator
- ⇒ Sample chamber
- ⇒ Detector
- ⇒ Display (data system)

#### 4.1 Light sources used in UV/VIS spectroscopy

Ideally, the light sources should be continuum sources that yield a constant intensity and low noise over long periods of time. Unfortunately, however, no type of lamp meets these criteria over the entire spectral range of a UV/VIS spectrophotometer.

Tungsten halogen lamps have proved particularly suitable for the visible range. The advantages of this type of lamp compared to the “ordinary” tungsten lamp lie in its greater durability and, due to higher filament temperature, a better spectral energy distribution in the visible region.

Deuterium lamps are used in the UV range starting from approx. 330 nm. This type of lamp provides a good yield in the mid-UV region and a fairly good energy distribution in the visible region. The radiation intensity of deuterium lamps continually decreases over the course of their useful life.

Most spectrophotometers use both types of lamps in parallel. At a particular wavelength, the lamp is then automatically selected.

Xenon lamps are used for applications that require high intensities, e.g. fluorescence spectrometry. This type of lamp provides a continuum over the entire UV/VIS range, with intensity decreasing towards the UV. The xenon lamp is not used in UV/VIS spectrometers as it produces significantly more noise than do tungsten halogen or deuterium lamps.

#### 4.2 Monochromator

Simple instruments, e.g. battery-operated portable spectrophotometers, utilise coloured glasses or *plastic films* as monochromators. Wavelength selection requires just a simple exchange of glasses (or plastic films).

In laboratory bench-top instruments, prisms and gratings are used as monochromator components. The advantage of prisms is that they are simple and therefore inexpensive, but the light dispersion they produce is nonlinear and temperature-dependent.

In grating monochromators, which are the most common type of monochromator used today, dispersion is almost constant and the transmitted wavelength is proportional to the sine of the angle of rotation. Compared to prisms, their disadvantage is that they generate higher-order spectra that reduce the yield of light and need to be removed by filters.

#### 4.3 Sample chamber

The design of the sample chamber depends on the individual type of spectrophotometer. In single-beam instruments, the reference cell and the sample cell are placed in the sample chamber consecutively, whereas in dual-beam instruments both cells are placed in the sample chamber at the same time. Sample chambers are, as a rule, designed to accommodate cells with path lengths of 0.1 to 10 cm.

It is always an advantage if the incident light enters the sample in a focussed manner in order to avoid scattering and reflection effects at the walls of the cells.

#### 4.4 Detector and data system

Two different types of detectors are employed: photomultiplier tubes and photodiodes. Photomultiplier tubes operate on the principle of the external photoelectric effect. The impact of a photon upon the photocathode results in the emission of electrons referred to as secondary electrons, which are captured by the positively charged anode. The number of these electrons is proportional to the intensity of the incident light. Several dynodes are arranged between the anode and the cathode, and voltage is applied to produce an amplification effect. Voltage applied between the dynodes in turn causes the emission of additional photoelectrons, leading to an exponential increase in secondary electrons (cf. Fig. 6). Usually, ten to fourteen dynodes are used for amplification.

$$i_{phot} = i_0 \times \delta^n \quad (6)$$

$i_{phot}$	Photoelectron current at the anode
$i_0$	Primary photoelectron current
$\delta$	Coefficient of dynode emission
$n$	Number of dynodes

Photodiodes operate on the principle of the internal photoelectric effect. Detection requires a series of photodiodes, and therefore detectors of this type are nowadays also re-

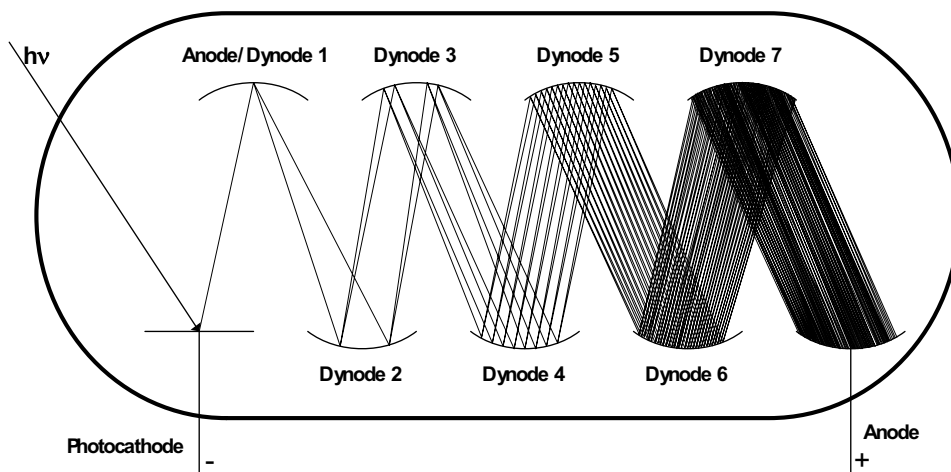

Fig. 6. Schematic diagram of a photomultiplier tube.



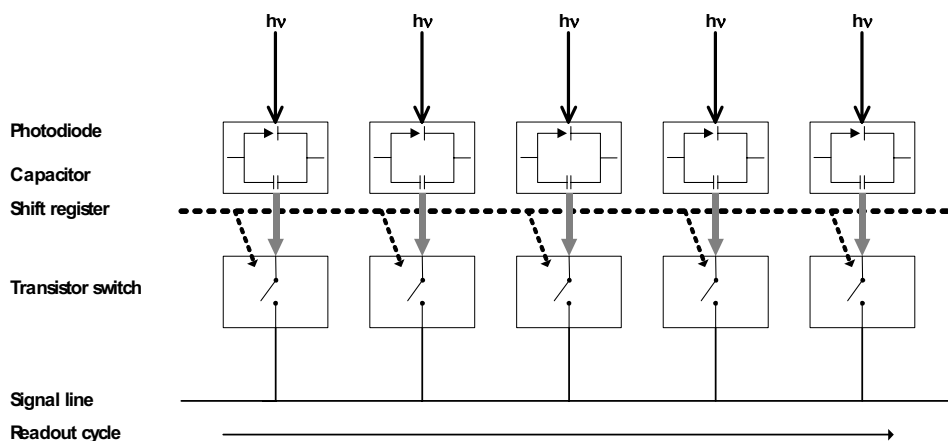

Fig. 7. Functional diagram of a diode array detector.

ferred to as diode array detectors. The advantage of these detectors is their short response time, which allows real-time recording of spectra. The mode of operation of a photodiode detector is shown in Figure 7.

The photodiodes are positioned side by side on a silicon chip. Each photodiode is connected to a transistor switch via a charged capacitor. When photons hit a photodiode, the resulting photocurrent discharges the respective capacitor. The capacitors are recharged at regular intervals that represent the scanning cycle of the diode array detector. The amount of charge required to recharge a capacitor is proportional to the original photocurrent. A diode array comprises between 200 and 1000 photodiodes, and a scanning cycle lasts a few milliseconds.

Personal computers (PCs) are generally used today as data systems for UV/VIS spectrophotometers as much as for other analytical systems. There are simpler instruments on the market that operate without a PC and use an integrated data system for data analysis.

## 5 Types of UV/VIS spectrophotometers

In principle, there are two basic types of construction for UV/VIS spectrophotometers:

- ⇒ Single-beam spectrophotometers
- ⇒ Dual-beam spectrophotometers

Single-beam spectrophotometers are lower in cost than dual-beam spectrophotometers and hence they are generally used in simple instruments such as portable spectrophotometers. Furthermore, different detectors call for different designs. When a photomultiplier is employed, the monochromator positioned in front of the sample chamber gener-

ates radiation of a selected wavelength (cf. Fig. 8 (a)). In the case of a diode array, however, polychromatic light passes through the sample before being split into its spectral components (cf. Fig. 8 (b)).

Modern laboratory instruments are based on the generally accepted dual-beam technology. It has the advantage that dual-beam instruments offer greater long-term stability and that aging of lamps plays no essential role. The disadvantages of this system are that additional optical components are required and sensitivity is lower than in single-beam instruments.

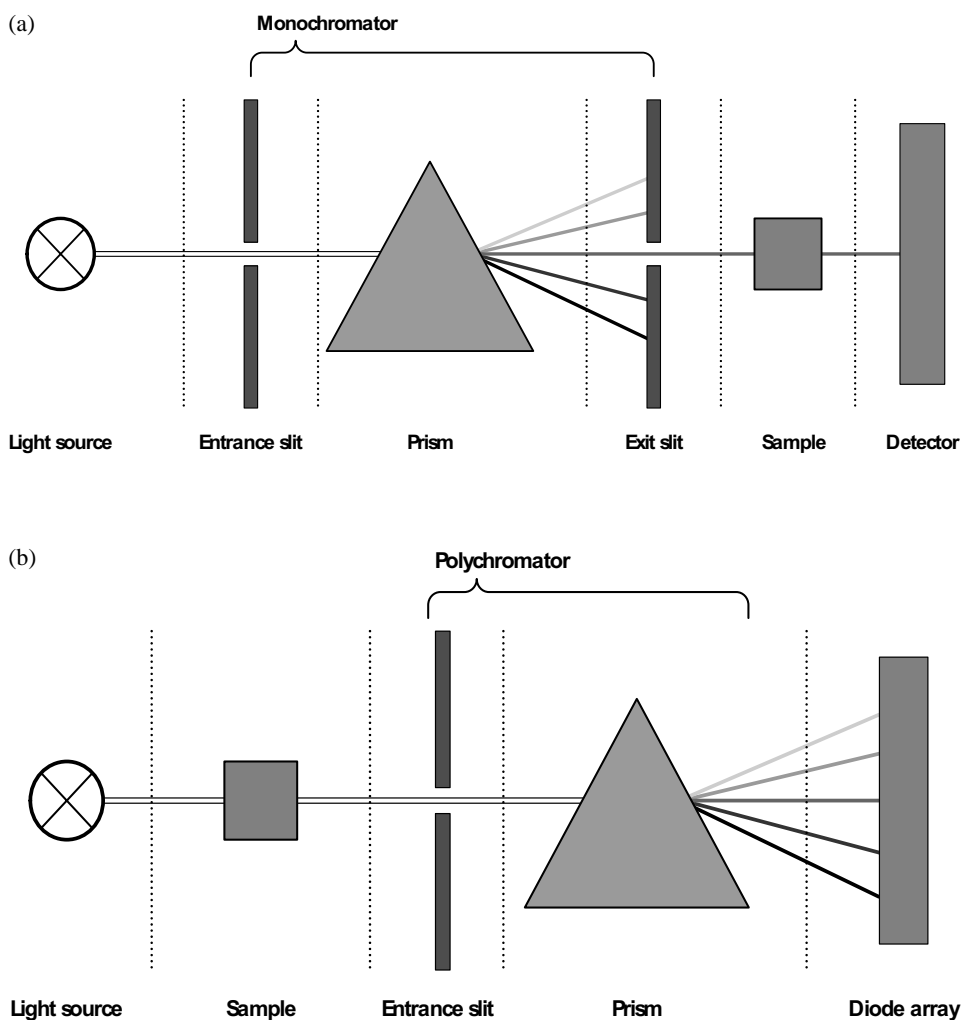

**Fig. 8.** Schematic diagram of a conventional single-beam spectrophotometer with a photomultiplier (a) or a diode array detector (b).

Dual-beam instruments, in turn, are available in two different basic designs.

- In instruments with a component known as a chopper, the light beam is alternately split to the sample and reference optical paths. The chopper is a rotating mirror that rotates around its own axis several times per second. This design eliminates effects such as changes in lamp intensity (drift). After passing through the sample chamber, the two light beams are directed to the same detector. The measurement of sample and reference thus occurs sequentially (see Fig. 9 (a)).
- In split-beam instruments, the light beam is split and sent along the sample and reference optical paths simultaneously. Each optical path has a separate detector and the sample and the reference are measured simultaneously. The advantage of this design is that the optical elements are mechanically simpler, but the use of two independent detectors introduces another potential source of error (see Fig. 9 (b)).

## 6 Sample handling and measurement

### 6.1 Cells (cuvettes)

In the great majority of cases, UV/VIS spectroscopy is used to measure liquid samples. The choice of cell is also always an important consideration. Both the material and the geometry of the cell affect the measurement. The most commonly used materials, glass and fused quartz, have different absorption characteristics. The only cells suitable for UV measurements are fused quartz cells, which are reasonably transparent down to about 210 nm. The polystyrene or acrylic plastic cells used in routine analysis have different absorption characteristics than glass cells, and for production-related reasons the walls of the cells are not parallel, thus limiting their applications.

The most frequently used cell geometry is that of the rectangular cell at which the light is aimed perpendicularly so as to largely prevent reflections. The amount of available sample determines the design of the cell. When there is enough sample, open-topped cells are used. Path lengths are between 0.1 and 10 cm. When sample volume is limited, cells with thicker side walls are used which have the same optical path length. In extreme cases, the volume of the cells can be reduced to just a few microlitres of liquid. Another frequently used type of cell is the flow-through cell.

Care should always be taken that the entrance and exit surfaces are flat, parallel and always clean, because scratches, in particular, cause scattering. In dual-beam instruments, pairs of well-matched cells with the same reflection and transmission characteristics should be used.

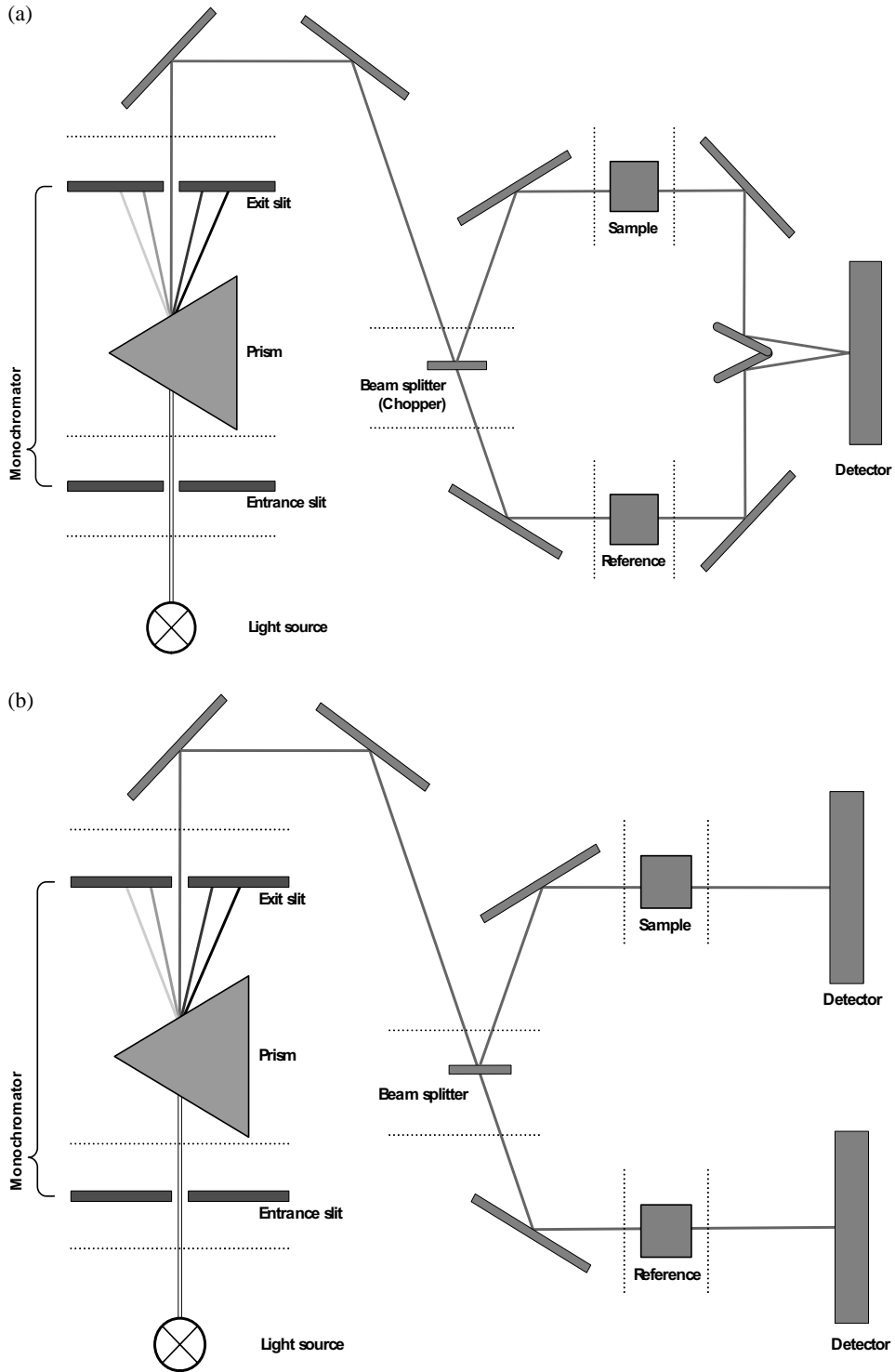

**Fig. 9.** Diagram of a dual-beam spectrophotometer with a beam splitter (chopper) and one detector (a) or a chopper and two detectors (b).

## 6.2 Solvents

The ideal solvent for UV/VIS spectrophotometry would readily dissolve all components of a sample and be non-flammable and non-toxic and would be transparent over the entire spectral range. Unfortunately no such solvent exists. In addition to water, numerous other solvents are used in UV/VIS spectrophotometry (cf. Table 1). When selecting a solvent, the wavelength up to which it can be used plays an important role.

**Table 1.** Important solvents in UV/VIS spectrophotometry.

Solvent	Cut-off wavelength* [nm]	Classification (Germany)**
Water	<195	None
Ethanol	207	K5, C, 2, F
Methanol	210	H, C, T, F
Cyclohexane	211	IIc, F
Dimethyl sulphoxide	270	H
Acetone	331	IIc, F

\* Transmittance for 10 mm path length is less than 25%

\*\* K5 = carcinogenic, group 5; H = skin-resorptive; C = pregnancy, group C; 2 = mutagenic, group 2;

IIc = pregnancy, group IIc; F = flammable; T = toxic

## 6.3 Effect of solvent, pH and temperature

The position and intensity of UV/VIS bands can be affected by a great number of factors. When comparing spectra it is always important to have exact records of the parameters solvent, sample temperature, concentration and measurement temperature.

The solvent used can affect the sample's absorbing chromophore. Water and alcohols can form hydrogen bonds with the result that the bands of polar substances are shifted. Thus, for example, the absorption maximum of acetaldehyde is  $\lambda = 292$  nm in nonpolar solvents such as n-heptane, whilst it is  $\lambda = 277$  nm in water.

Changes in pH can also have a great effect on band position. This effect is exploited analytically in pH indicators, where the chromophore changes colour when the pH exceeds or falls below a certain value.

The effect of temperature is less pronounced. However, simple thermic expansion of the solution may be sufficient to change band intensity. The temperature in the sample chambers of spectrophotometers is sufficiently constant to render this effect negligible.

---

## 7 Spectrophotometric methods in the collection

Spectrophotometric methods frequently suffer from the disadvantage that compounds of comparable chemical reactivity will interfere with spectrophotometric determination. This also constitutes a reason why spectrophotometric methods are increasingly being replaced or supplemented by chromatographic or other procedures. Chromatographic procedures have the advantage that sources of interference are more readily eliminated by separation. Table 2 lists the procedures compiled in the Collection (as of Supplement 13) which continue to the present day to play a role in the analysis of hazardous substances in workplace air.

## 8 References

- [1] Ullmann's Encyclopedia of Industrial Chemistry (2005) Electronic Release, 7<sup>th</sup> ed., Verlag Wiley-VCH, Weinheim
- [2] *Barrow, G.M.* (1980) *Physikalische Chemie Teil II*, Bohmann-Verlag, Wien, Friedrich Vieweg & Sohn, Braunschweig/Wiesbaden
- [3] *Fundamentals of modern UV-VISible spectroscopy* (1996) Hewlett-Packard Publication Nr. 12-5965-5123E, Waldbronn

Author: *D. Breuer*

**Table 2.** Overview of the spectrophotometric methods contained in this collection of methods (as of 2003).

Analyte	Published in	Detection wavelength	Sampling	Solvent	Reagent	Interference
NH <sub>3</sub>	Suppl. 7/1992	620 nm	Impinger, filled with H <sub>2</sub> SO <sub>4</sub> (0.005 M)	Water	Phenol Sodium hypochloride Na <sub>2</sub> [Fe(CN) <sub>5</sub> NO]	Amines
HCl	Suppl. 2/1980	450 nm	Impinger, filled with NaOH (0.1 M)	Water	Mercury thiocyanate Iron(III) salt solution	Chlorides, chlorine, bromides, H <sub>2</sub> S
HCHO	Suppl. 3/1982	570 nm	Silica gel tube	Water	Pararosaniline Na <sub>2</sub> [HgCl <sub>4</sub> ] Na <sub>2</sub> SO <sub>3</sub>	Acetaldehyde Furfuryl alcohol
O <sub>3</sub>	Suppl. 8/1993	623 nm	Impinger, filled with indigo carmine solution	Water	Indigo carmine	NO <sub>2</sub>
PH <sub>3</sub>	Suppl. 9/1994	625 nm	Silica gel impregnated with Hg(CN) <sub>2</sub>	Isobutanol/ toluene	KMnO <sub>4</sub> (NH <sub>4</sub> ) <sub>2</sub> Mo <sub>7</sub> O <sub>24</sub>	Phosphates
SO <sub>2</sub>	Suppl. 2/1980	560 nm	Impinger, filled with Na <sub>2</sub> [HgCl <sub>4</sub> ] solution	Water	Pararosaniline Formaldehyde Na <sub>2</sub> [HgCl <sub>4</sub> ]	NO <sub>2</sub>
H <sub>2</sub> O <sub>2</sub>		385 nm	Impinger, filled with potassium titanium oxide oxalate solution	Water	potassium titanium oxide oxalate	None