

2 Axiomatic Design

2.1 Introduction

Axiomatic design is a design theory that was created and popularized by Professor Suh of the Massachusetts Institute of Technology (Suh 1990, 2000). Actually, it is a general design framework, rather than a design theory. As the word “framework” indicates, it can be applied to all design activities. It consists of two axioms. One is the Independence Axiom and the other is the Information Axiom. A good design should satisfy the two axioms while a bad design does not. It is well known that the word “axiom” originates from geometry. An axiom cannot be proved and becomes obsolete when a counterexample is validated. So far, a counterexample has not been found in axiomatic design. Instead, many useful design examples with axioms are validated.

Design is the interplay between “what we want to achieve” and “how we achieve it.” A designer tries to obtain what he/she wants to achieve through appropriate interplay between both sides. The engineering sequence can be classified into four domains as illustrated in Figure 2.1. Customer attributes (CAs) are delineated in the customer domain. In other words, CAs are the customer needs. CAs are transformed into functional requirements (FRs) in the functional domain. FRs are defined by engineering words. This is equivalent to “what we want to achieve.” FRs are satisfied by defining or selecting design parameters (DPs) in the physical domain. Mostly, this procedure is referred to as the design process. Production variables (PVs) are determined from DPs in the same manner. The aspects for the next domain are determined from the relationship between the two domains, and this process is called mapping. A good design process means an efficient mapping process.

Design axioms are defined from common principles for engineering activities as follows:

Axiom 1: The Independence Axiom

Maintain the independence of FRs.

Alternate Statement 1: An optimal design always maintains the independence of FRs.

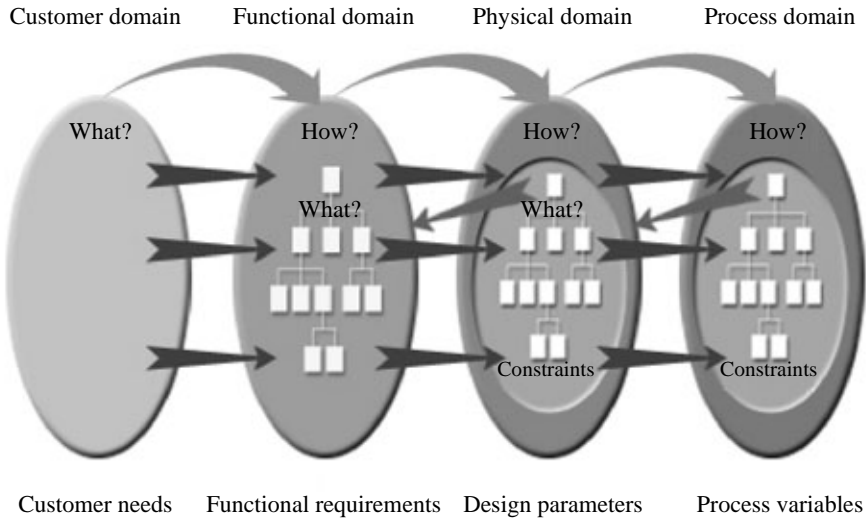

Figure 2.1. Relationship of domains, mapping and design spaces

Alternate Statement 2: In an acceptable design, DPs and FRs are related in such a way that a specific DP can be adjusted to satisfy its corresponding FR without affecting other functional requirements.

Axiom 2: The Information Axiom

Minimize the information content of the design.

Alternate Statement: The best design is a functionally uncoupled design that has minimum information content.

The axioms may look simple. However, they have significant meanings in engineering. Details of the axioms will be explained later. Axiom 1 is an expression that design engineers know consciously or subconsciously. When we design a complex system, the axiom tells us that a DP should be defined to independently satisfy its corresponding FR. In other words, the FRs of the functional domain in Figure 2.1 should be independently satisfied by DPs of the physical domain. Otherwise, the design is not suitable. When multiple designs are found from Axiom 1, the best one can be chosen based on Axiom 2. That is, the best design has minimum information content that is usually quantified by the probability of success. It also corresponds to the engineering intuition that design engineers usually have in mind. Axiom 2 is related to robust design and it will be explained later. Although the axioms are expressed simply, real application can be very difficult.

As explained earlier, axioms are defined in geometry. As in geometry, theorems and corollaries are derived from axioms (see Appendix 2.A).

2.2 The Independence Axiom

2.2.1 The Independence Axiom

The Independence Axiom indicates that the aspects in the proceeding domain should be independently satisfied by the choices carried out in the next domain. The domains are illustrated in Figure 2.1. The relationship of FR–DP is defined to be independent. When plural FRs are defined, each DP should satisfy each corresponding FR. The relationship can be expressed by a design matrix. Using vector notations for FRs and DPs, the relationship is expressed as the following design equation:

$$\mathbf{FR} = \mathbf{A} \mathbf{DP} \quad (2.1)$$

Matrix \mathbf{A} is called a design matrix. The characteristics of matrix \mathbf{A} determine if the Independence Axiom is satisfied. Suppose we have three FRs and DPs. Matrix \mathbf{A} is as follows:

$$\begin{bmatrix} FR_1 \\ FR_2 \\ FR_3 \end{bmatrix} = \begin{bmatrix} A_{11} & A_{12} & A_{13} \\ A_{21} & A_{22} & A_{23} \\ A_{31} & A_{32} & A_{33} \end{bmatrix} \begin{bmatrix} DP_1 \\ DP_2 \\ DP_3 \end{bmatrix} \quad (2.2)$$

FR–DP relationships according to matrix \mathbf{A} are shown in Table 2.1. If the design matrix is a diagonal matrix, it is an uncoupled design. Because each DP can satisfy a corresponding FR, the uncoupled design perfectly satisfies the Independence Axiom. When the design matrix is triangular as shown in the second case of Table 2.1, the design is a decoupled design. A decoupled design satisfies the Independence Axiom if the design sequence is correct. In the second row of Table 2.1, DP_1 is first determined for FR_1 and fixed. FR_2 is satisfied by the choice of DP_2 and the fixed DP_1 . DP_3 is determined in the same manner with the fixed DP_1 and DP_2 .

When a design matrix is neither diagonal nor triangular, the design becomes a coupled design. In a coupled design, no sequences of DPs can satisfy the FRs independently. Therefore, an uncoupled or a decoupled design satisfies the Independence Axiom and a coupled design does not. If a design is coupled, an uncoupled or decoupled design must be found through a new choice of DPs. For the i th FR or DP, the subscript notation is used in this book. FR_i is frequently expressed by FRI . With design matrices, multiplication and addition are permitted; however, other manipulations such as coordinate transformation are not permitted.

It is noted that constraints (Cs) exist in the design. Constraints are generally defined from design specifications and they must be satisfied. Constraints can be

Table 2.1. FR–DP relationship according to the design matrix

	Design equation	Design process
Uncoupled design	$\begin{bmatrix} FR_1 \\ FR_2 \\ FR_3 \end{bmatrix} = \begin{bmatrix} A_{11} & 0 & 0 \\ 0 & A_{22} & 0 \\ 0 & 0 & A_{33} \end{bmatrix} \begin{bmatrix} DP_1 \\ DP_2 \\ DP_3 \end{bmatrix}$	$\begin{aligned} FR_1 &= A_{11} \times DP_1 \\ FR_2 &= A_{22} \times DP_2 \\ FR_3 &= A_{33} \times DP_3 \end{aligned}$
Decoupled design	$\begin{bmatrix} FR_1 \\ FR_2 \\ FR_3 \end{bmatrix} = \begin{bmatrix} A_{11} & 0 & 0 \\ A_{21} & A_{22} & 0 \\ A_{31} & A_{32} & A_{33} \end{bmatrix} \begin{bmatrix} DP_1 \\ DP_2 \\ DP_3 \end{bmatrix}$	$\begin{aligned} FR_1 &= A_{11} \times DP_1 \\ FR_2 &= A_{21} \times DP_1 + A_{22} \times DP_2 \\ FR_3 &= A_{31} \times DP_1 + A_{32} \times DP_2 \\ &\quad + A_{33} \times DP_3 \end{aligned}$
Coupled design	$\begin{bmatrix} FR_1 \\ FR_2 \\ FR_3 \end{bmatrix} = \begin{bmatrix} A_{11} & A_{12} & A_{13} \\ A_{21} & A_{22} & A_{23} \\ A_{31} & A_{32} & A_{33} \end{bmatrix} \begin{bmatrix} DP_1 \\ DP_2 \\ DP_3 \end{bmatrix}$	$\begin{aligned} FR_1 &= A_{11} \times DP_1 + A_{12} \times DP_2 \\ &\quad + A_{13} \times DP_3 \\ FR_2 &= A_{21} \times DP_1 + A_{22} \times DP_2 \\ &\quad + A_{23} \times DP_3 \\ FR_3 &= A_{31} \times DP_1 + A_{32} \times DP_2 \\ &\quad + A_{33} \times DP_3 \end{aligned}$

defined without regard to independence of FRs and coupled by DPs. As illustrated in Figure 2.1, the constraints can be defined in the DP or PV domains.

The following example shows an application of the Independence Axiom. Generally, an imperative sentence is used for the expression of an FR and a noun is used for a DP.

Example 2.1 [Design of a Refrigerator Door] (NSF 1998, Suh 2000)

Figure 2.2 shows two refrigerator doors that we most frequently encounter. Which one has the better design? To answer the question, the doors are analyzed based on an axiomatic design viewpoint. Functional requirements are defined as follows:

FR_1 : Provide access to the items stored in the refrigerator.

FR_2 : Minimize energy loss.

Solution

Design parameters for the vertically hung door in Figure 2.2a are as follows:

DP_1 : Vertically hung door

DP_2 : Thermal insulation material in the door



(a) Vertically hung door



(b) Horizontally hung door

Figure 2.2. Refrigerator doors

The design equation may be stated as

$$\begin{bmatrix} FR_1 \\ FR_2 \end{bmatrix} = \begin{bmatrix} X & 0 \\ X & X \end{bmatrix} \begin{bmatrix} DP_1 \\ DP_2 \end{bmatrix} \quad (2.3)$$

where an X indicates a nonzero value, and hence a dependence between an FR and a DP.

From Equation 2.3, the design is a decoupled one and satisfies the Independence Axiom. However, when we open the door, energy loss occurs due to the X in the off-diagonal term. Now, the horizontally hung door in Figure 2.2b is analyzed.

DP_1 : Horizontally hung door

DP_2 : Thermal insulation material in the door

The design equation is made as follows:

$$\begin{bmatrix} FR_1 \\ FR_2 \end{bmatrix} = \begin{bmatrix} X & 0 \\ 0 & X \end{bmatrix} \begin{bmatrix} DP_1 \\ DP_2 \end{bmatrix} \quad (2.4)$$

When we open the horizontally hung door, cold air remains in the refrigerator and energy loss can be minimized. Therefore, the horizontally hung door has an uncoupled design and is a better design than the vertically hung door. Is the horizontally hung door always better? As far as the functional requirements defined here are kept, it is correct. Suppose that constraints are proposed for the amount of stored food or convenience to access items. Then the problem will be

different. If a refrigerator with a horizontally hung door violates the constraints, it cannot be accepted regardless of the satisfaction of the Independence Axiom. When constraints exist, they should be checked first.

Example 2.2 [Design of a Water Faucet] (Suh 2000)

A faucet is designed. The user should be able to control the temperature and the running rate of water. Since there are many commercialized faucets, they are evaluated. The functional requirements of a faucet are defined as follows:

- FR_1 : Control the flow of water (Q).
- FR_2 : Control the temperature of water (T).

Solution

Analyzing the product in Figure 2.3a, DPs and the design equation are defined as follows:

- DP_1 : Angle ϕ_1
- DP_2 : Angle ϕ_2

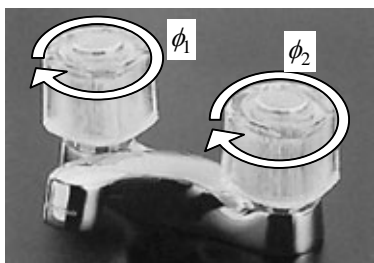

(a) Coupled design

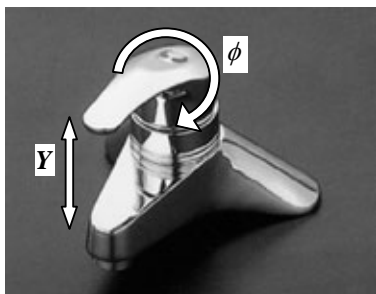

(c) Uncoupled design

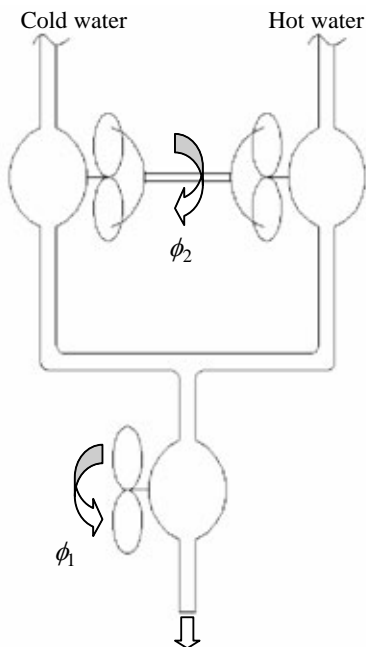

(b) Uncoupled design

Figure 2.3. Example of a water faucet

$$\begin{bmatrix} FR_1(Q) \\ FR_2(T) \end{bmatrix} = \begin{bmatrix} X & X \\ X & X \end{bmatrix} \begin{bmatrix} DP_1(\phi_1) \\ DP_2(\phi_2) \end{bmatrix} \quad (2.5)$$

As shown in Equation 2.5, the design is coupled. Thus, the design is not acceptable.

Another example is presented in Figure 2.3b. The design is analyzed as follows:

DP_1 : Angle ϕ_1

DP_2 : Angle ϕ_2

$$\begin{bmatrix} FR_1(Q) \\ FR_2(T) \end{bmatrix} = \begin{bmatrix} X & 0 \\ 0 & X \end{bmatrix} \begin{bmatrix} DP_1(\phi_1) \\ DP_2(\phi_2) \end{bmatrix} \quad (2.6)$$

Because the design matrix is diagonal, the design is uncoupled. Therefore, it satisfies the Independence Axiom and is acceptable.

One more design is illustrated in Figure 2.3c.

DP_1 : Displacement Y

DP_2 : Angle ϕ

$$\begin{bmatrix} FR_1(Q) \\ FR_2(T) \end{bmatrix} = \begin{bmatrix} X & 0 \\ 0 & X \end{bmatrix} \begin{bmatrix} DP_1(Y) \\ DP_2(\phi) \end{bmatrix} \quad (2.7)$$

The design matrix is diagonal; therefore, the design is uncoupled. We have two uncoupled designs. Which one is better? It is easy to manipulate the one in Figure 2.3c. This can be explained by the Information Axiom, which will be introduced later. The design in Figure 2.3c is the best from the viewpoint of the Information Axiom. Actually, the one in Figure 2.3c is becoming popular. This conclusion is made based on engineering functional requirements. If aesthetic aspects are important, different decisions can be made.

When we design a complicated system, a definition of a simple FR–DP relationship may not be sufficient. Then we can decompose the relationship. As illustrated in Figure 2.4, a new relationship is defined by a zigzagging process between the functional and physical domains. The zigzagging process is presented by the numbers in Figure 2.4. It is noted that DPs are defined according to FRs in the same level and FRs of the lower level are defined based on the characteristics of DPs in the upper level. This decomposition process continues until the leaf (bottom) level is reached. In Figure 2.5, the decomposition process for a lathe is illustrated (Suh 1999).

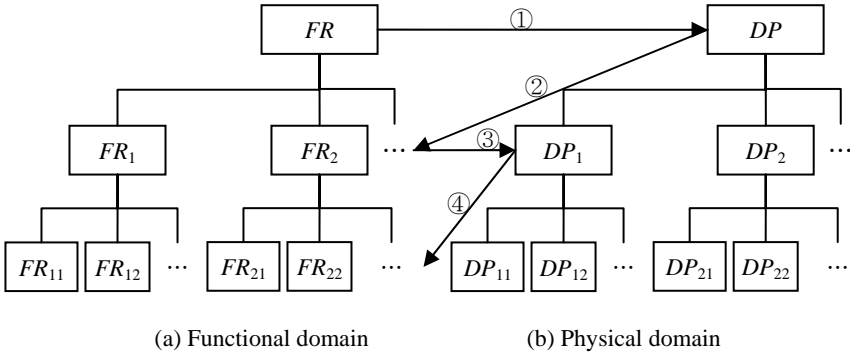

Figure 2.4. Zigzagging process between domains

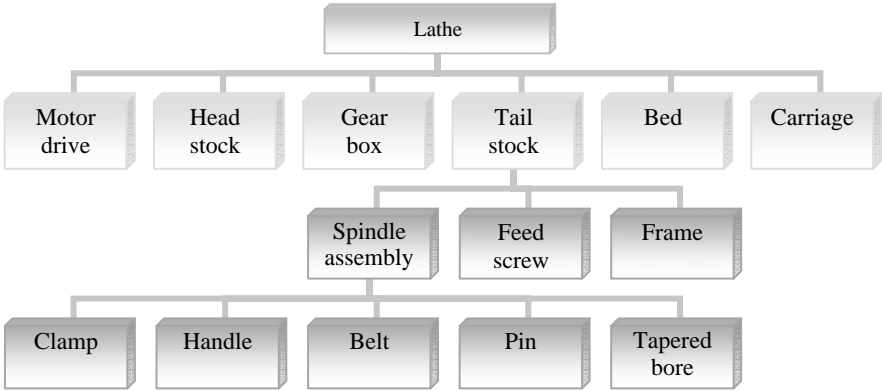
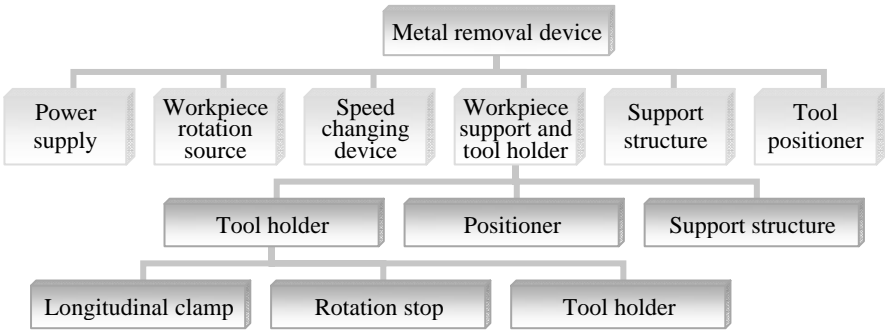

Figure 2.5. Decomposition process for a lathe using axiomatic design

2.2.2 Independence

Using FR–DP coordinates, Figure 2.6 presents diagrams of mapping processes when the numbers of FRs and DPs are 2. Each design can be expressed by a design equation as follows (Rinderle and Suh 1982):

$$\begin{bmatrix} FR_1 \\ FR_2 \end{bmatrix} = \begin{bmatrix} A_{11} & 0 \\ 0 & A_{22} \end{bmatrix} \begin{bmatrix} DP_1 \\ DP_2 \end{bmatrix} \quad \text{uncoupled design (Figure 2.6a)} \quad (2.8)$$

$$\begin{bmatrix} FR_1 \\ FR_2 \end{bmatrix} = \begin{bmatrix} A_{11} & A_{12} \\ 0 & A_{22} \end{bmatrix} \begin{bmatrix} DP_1 \\ DP_2 \end{bmatrix} \quad \text{decoupled design (Figure 2.6b)} \quad (2.9)$$

$$\begin{bmatrix} FR_1 \\ FR_2 \end{bmatrix} = \begin{bmatrix} A_{11} & A_{12} \\ A_{21} & A_{22} \end{bmatrix} \begin{bmatrix} DP_1 \\ DP_2 \end{bmatrix} \quad \text{coupled design (Figure 2.6c)} \quad (2.10)$$

An uncoupled design is presented in Figure 2.6a. The point A has $(FR_1)_A$ and $(FR_2)_A$ for $(DP_1)_A$ and $(DP_2)_A$, respectively. The points B, C and D have the same characteristics. If the design is to be changed from A to C, the path A–D–C or the path A–B–C can be selected. That is, the uncoupled design is independent of the design path.

The decoupled design in Figure 2.6b is different. Suppose we want to change the design from A to C. First, DP_2 should be changed from $(DP_2)_A$ to $(DP_2)_E$. In this process, DP_1 is fixed and both FR_1 and FR_2 are changed. Second, DP_2 is fixed and DP_1 is changed from $(DP_1)_E$ to $(DP_1)_C$. In this process, FR_2 is fixed and FR_1 is changed. Thus, the decoupled design relies upon the design path. That is, DP_2 should be determined first and DP_1 should be determined later.

Now, look at the coupled design in Figure 2.6c. When the design is changed from A to C, the effect is the same no matter what design parameter is changed. Suppose DP_1 is changed first. To satisfy FR_1 , DP_1 can be changed from A to C', and then FR_2 is also changed. Thus the design should be changed from C' to C'' to satisfy FR_2 . Then FR_1 is changed again and DP_1 should be changed again. Therefore, the design process is repetitively performed until the design converges. This can be quite a complicated process. In particular, convergence may be impossible when the design is highly nonlinear.

Figure 2.7 briefly presents the above relationships. The characteristics of the design equations can be expressed by α_1 , α_2 and θ in Figure 2.7. The ideal uncoupled design is obtained when $\alpha_1 = \alpha_2 = 0$ and $\theta = 90^\circ$. As an index for coupling, the following index R called “reangularity” is defined:

$$R = \sin \theta = (1 - \cos^2 \theta)^{1/2} \quad (2.11)$$

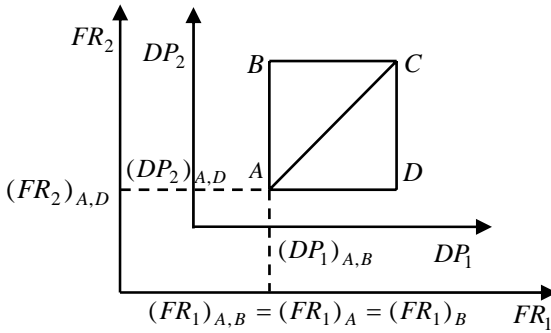

(a) Uncoupled design

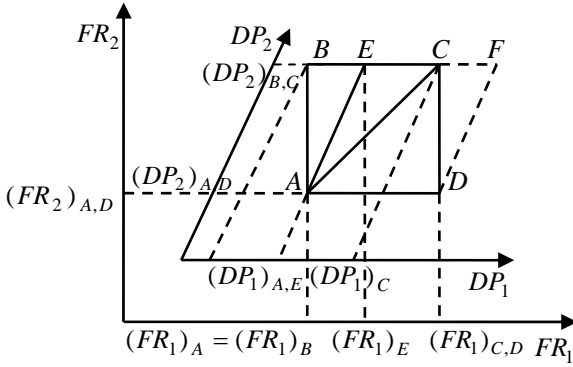

(b) Decoupled design

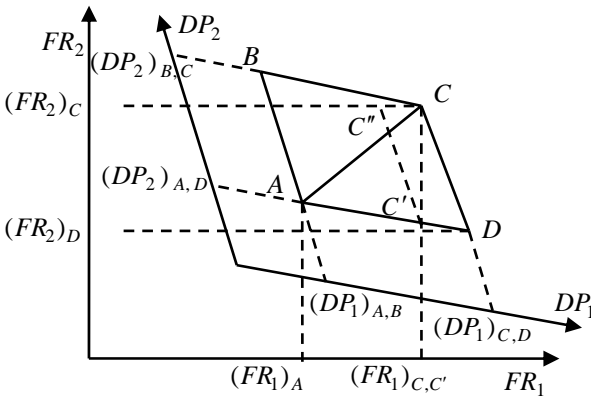

(c) Coupled design

Figure 2.6. Mapping process from the FR domain to the DP domain for each design

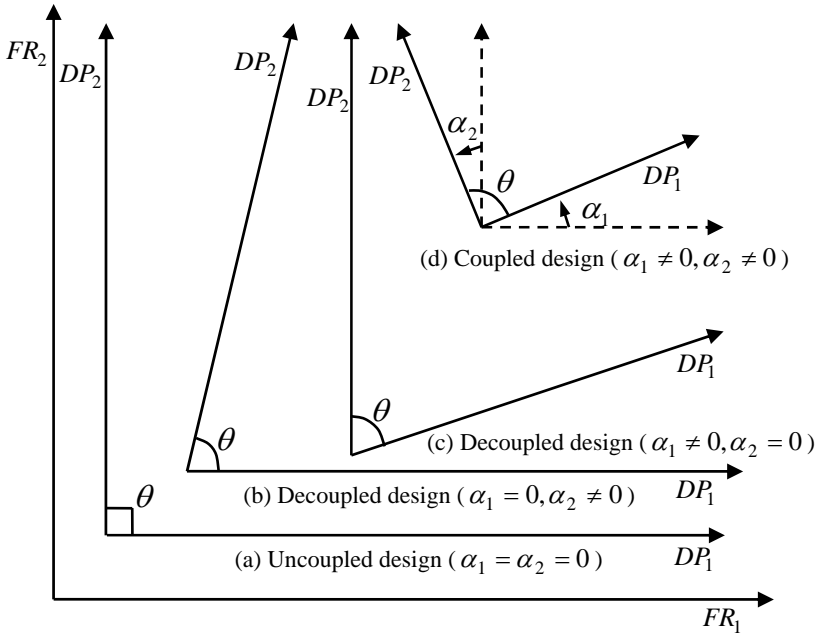

Figure 2.7. Schematic view of each design according to the coupling characteristics

If the numbers of FRs and DPs are n and each element of the design equation is A_{ij} , R is as follows:

$$R = \prod_{\substack{i=1, n-1 \\ j=1+i, n}} \left[1 - \frac{(\sum_{k=1}^n A_{ki} A_{kj})^2}{(\sum_{k=1}^n A_{ki}^2)(\sum_{k=1}^n A_{kj}^2)} \right]^{1/2} \quad (2.12)$$

When $\theta=90^\circ$, the DP_1 -axis is orthogonal to the DP_2 -axis and $R = 1$.

Reangularity R is not sufficient to show all the cases of coupling. The fact that $R \rightarrow 1$ does not guarantee that $\alpha_1 \rightarrow 0$ and $\alpha_2 \rightarrow 0$. $\alpha_1 = \alpha_2 = 0$ means that the design equation is diagonal and larger diagonal terms make coupling lower. Therefore, another index called “semangularity” (this means the same angle quality in Latin) S is defined as follows:

$$S = \prod_{j=1}^n \frac{|A_{jj}|}{(\sum_{k=1}^n A_{kj}^2)^{1/2}} \quad (2.13)$$

Table 2.2. Reangularity and semangularity for each design

	Uncoupled design	Decoupled design	Coupled design
Reangularity	1	$R = S < 1$	$R \neq S < 1$
Angle between column vectors (θ)	90°	θ	θ
Semangularity	1	$S = R < 1$	$S \neq R < 1$

When the design equation is diagonal, $\alpha_1 = \alpha_2 = 0$ and $S = 1$. Table 2.2 shows the characteristics of each design for reangularity and semangularity.

Example 2.3 [Reangularity and Semangularity of a Decoupled Design]

Prove that R and S of Equation 2.9 are the same for the decoupled design.

Solution 1

When there are two functional requirements, R and S are as follows using Equations 2.12 and 2.13:

$$R = \left[1 - \frac{(A_{11}A_{12} + A_{21}A_{22})^2}{(A_{11}^2 + A_{21}^2)(A_{12}^2 + A_{22}^2)} \right]^{1/2} \quad (2.14a)$$

$$S = \left[\frac{|A_{11}|}{\sqrt{A_{11}^2 + A_{21}^2}} \right] \left[\frac{|A_{22}|}{\sqrt{A_{12}^2 + A_{22}^2}} \right] \quad (2.14b)$$

In Equation 2.9, $A_{21} = 0$ and Equation 2.14 becomes

$$R = \left[1 - \frac{A_{11}^2 A_{12}^2}{A_{11}^2 (A_{12}^2 + A_{22}^2)} \right]^{1/2} = \left[\frac{A_{11}^2 A_{22}^2}{A_{11}^2 (A_{12}^2 + A_{22}^2)} \right]^{1/2} = \frac{|A_{22}|}{\sqrt{A_{12}^2 + A_{22}^2}} \quad (2.15a)$$

$$S = \left[\frac{|A_{11}|}{\sqrt{A_{11}^2}} \right] \left[\frac{|A_{22}|}{\sqrt{A_{12}^2 + A_{22}^2}} \right] = \frac{|A_{22}|}{\sqrt{A_{12}^2 + A_{22}^2}} \quad (2.15b)$$

Therefore, R and S are the same.

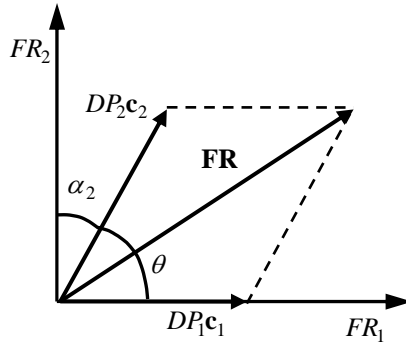

Figure 2.8. Vector representation of Example 2.3

Solution 2

Solve the problem geometrically. Define $\mathbf{c}_1 = [A_{11} \ 0]^T$ and $\mathbf{c}_2 = [A_{12} \ A_{22}]^T$. If the two functional requirements are expressed by a vector \mathbf{FR} , then $\mathbf{FR} = DP_1\mathbf{c}_1 + DP_2\mathbf{c}_2$. This is geometrically represented in Figure 2.8. From Figure 2.8, R and S are as follows:

$$\cos \theta = \frac{\mathbf{c}_1^T \mathbf{c}_2}{|\mathbf{c}_1| |\mathbf{c}_2|} = \frac{A_{11}A_{12}}{\sqrt{A_{11}^2} \sqrt{A_{12}^2 + A_{22}^2}} \quad (2.16a)$$

$$R = \sin \theta = (1 - \cos^2 \theta)^{1/2} = \left[1 - \frac{A_{11}^2 A_{12}^2}{A_{11}^2 (A_{12}^2 + A_{22}^2)} \right]^{1/2} \quad (2.16b)$$

$$= \left[\frac{A_{11}^2 A_{22}^2}{A_{11}^2 (A_{12}^2 + A_{22}^2)} \right]^{1/2} = \frac{|A_{22}|}{\sqrt{A_{12}^2 + A_{22}^2}}$$

$$S = \cos \alpha_1 \cos \alpha_2 = \left[\frac{|A_{11}|}{\sqrt{A_{11}^2 + 0^2}} \right] \left[\frac{|A_{22}|}{\sqrt{A_{12}^2 + A_{22}^2}} \right] = \frac{|A_{22}|}{\sqrt{A_{12}^2 + A_{22}^2}} \quad (2.16c)$$

Therefore, R and S are the same.

When the design equation is nonlinear with respect to design parameters, A_{ij} of Equation 2.2 may not be constant. Thus, although the uncoupled relationship is satisfied at a design point, it may not be satisfied at other points. In this case, an approximation by Taylor expansion can be employed. FR_i in Equation 2.2 can be approximated as follows:

$$FR_i = (FR_i)_0 + \delta FR_i = (FR_i)_0 + \sum_{j=1}^3 \frac{\partial FR_i}{\partial DP_j} \delta DP_j \quad (2.17)$$

where $(FR_i)_0$ is the current functional requirement. Using Equation 2.17, the design equation at (DP_1, DP_2, DP_3) is defined as follows:

$$\begin{bmatrix} \delta FR_1 \\ \delta FR_2 \\ \delta FR_3 \end{bmatrix} = \begin{bmatrix} \frac{\partial FR_1}{\partial DP_1} & \frac{\partial FR_1}{\partial DP_2} & \frac{\partial FR_1}{\partial DP_3} \\ \frac{\partial FR_2}{\partial DP_1} & \frac{\partial FR_2}{\partial DP_2} & \frac{\partial FR_2}{\partial DP_3} \\ \frac{\partial FR_3}{\partial DP_1} & \frac{\partial FR_3}{\partial DP_2} & \frac{\partial FR_3}{\partial DP_3} \end{bmatrix} \begin{bmatrix} \delta DP_1 \\ \delta DP_2 \\ \delta DP_3 \end{bmatrix} \quad (2.18)$$

As shown in Equation 2.18, the design matrix is a matrix with partial derivatives, which defines the relationship between increments of FRs and DPs. The effort to find an uncoupled design is to find a design window where the design matrix is diagonal. Therefore, although the Independence Axiom is satisfied at a design point, it is not guaranteed if the design is changed.

Can we consider a design to be uncoupled when the off-diagonal terms are quite small compared to the diagonal terms? The following equation is an example:

$$\begin{bmatrix} FR_1 \\ FR_2 \\ FR_3 \end{bmatrix} = \begin{bmatrix} X & x & x \\ x & X & x \\ x & x & X \end{bmatrix} \begin{bmatrix} DP_1 \\ DP_2 \\ DP_3 \end{bmatrix} \quad (2.19)$$

where $X \gg x$. The decision can be made based on the tolerance ranges and the sizes of X and x . Theorem 2.A.8 in Appendix 2.A provides the reason for this. Theorem 2.A.8 is as follows:

Theorem 2.A.8 [Independence and Design Range]

A design is an uncoupled design when the designer-specified range is greater than

$$\sum_{j=1, j \neq i}^n \left(\frac{\partial FR_i}{\partial DP_j} \right) \Delta DP_j \quad (2.20)$$

in which case the off-diagonal elements of the design matrix can be neglected from the design consideration.

When the magnitude of Equation 2.20 is very small, in other words, when x is considerably small compared to X in Equation 2.19, Equation 2.19 can be regarded as an uncoupled design.

Suppose that the current design is $\mathbf{FR}_0 = \mathbf{A} \mathbf{DP}_0$. The change of the design parameters is $\Delta \mathbf{DP}$. The change of the functional requirements is $\Delta \mathbf{FR}$ and it is obtained by replacing δ with Δ in Equation 2.18. $(\Delta FR_i)_{\text{diag}} \equiv \frac{\partial FR_i}{\partial DP_i} \Delta DP_i$ and $(\Delta FR_i)_{\text{diag}}$ is the change of FR_i by the i th diagonal term with respect to the change of DP_i . Generally, the diagonal term is the largest. Therefore, $(\Delta FR_i)_{\text{diag}}$ has the largest impact on the FR_i change. If we exclude $(\Delta FR_i)_{\text{diag}}$ from $\Delta \mathbf{FR}$, the remainder is the off-diagonal terms. When the influence from the off-diagonal terms is very small, we do not need to consider them. This is expressed as

$$\sum_{\substack{j=1 \\ j \neq i}}^n \left(\frac{\partial FR_i}{\partial DP_j} \right) \Delta DP_j \leq (\Delta FR_i)_{\text{allowable}}, \quad i = 1, \dots, n \quad (2.21)$$

where $(\Delta FR_i)_{\text{allowable}}$ is the allowable tolerance specified by the designer. Equation 2.21 means the range where the influence of the off-diagonal terms is negligible.

Example 2.4 [The Range of DPs to Be Considered as a Decoupled Design]

Suppose we have the following design:

$$\begin{bmatrix} FR_1 \\ FR_2 \end{bmatrix} = \begin{bmatrix} X & x \\ y & X \end{bmatrix} \begin{bmatrix} DP_1 \\ DP_2 \end{bmatrix} \quad (2.22)$$

where $X \gg x$, $X \gg y$. The allowable tolerance in Equation 2.22 is $(\Delta FR_i)_{\text{allowable}}$, $i = 1, 2$.

- (1) Obtain the range of design parameters with which we can consider the design as an uncoupled design.
- (2) Obtain the range of design parameters with which we can consider the design as a decoupled design.

Solution

- (1) Ranges of ΔDP_1 and ΔDP_2 that satisfy $x \Delta DP_2 \leq (\Delta FR_1)_{\text{allowable}}$ and $y \Delta DP_1 \leq (\Delta FR_2)_{\text{allowable}}$.

- (2) Ranges of ΔDP_1 and ΔDP_2 that satisfy $x\Delta DP_2 \leq (\Delta FR_1)_{\text{allowable}}$ or $y\Delta DP_1 \leq (\Delta FR_2)_{\text{allowable}}$.

2.2.3 Physical Integration

There is a saying that a simple design is a good one. From this statement, we may guess that a good design makes one DP satisfy multiple FRs. In other words, a coupled design is better. This aspect is very confusing in axiomatic design. However, from an axiomatic design viewpoint, this is the case where multiple DPs make a physical entity. That is, multiple DPs satisfy FRs of the same number. This is called “physical integration.” Physical integration is desirable because the information quantity can be reduced. The following example is a typical example of physical integration.

Example 2.5 [Bottle–can Opener] (NSF 1998, Suh 1999)

Suppose we need a device that can open bottles and cans. Functional requirements are defined as follows:

FR_1 : Design a device that can open bottles.

FR_2 : Design a device that can open cans.

Solution

The device in Figure 2.9 has one physical entity for the bottle opener and can opener. However, two DPs at both ends independently satisfy the two functional requirements. Therefore, the design in Figure 2.9 satisfies the Independence Axiom. If the constraint set includes “both functions should be simultaneously used,” then a different design should be investigated.



Figure 2.9. Bottle–can opener



Figure 2.10. Beverage can

Example 2.6 [Beverage Can Design] (NSF 1998, Suh 2001)

Consider an aluminum beverage can that contains liquid as illustrated in Figure 2.10. According to an expert working at one aluminum can manufacturer, there are 12 FRs for the can. Plausible FRs: contain axial and radial pressure, withstand moderate impact when the can is dropped from a certain height, allow stacking on top of each other, provide easy access to the liquid in the can, minimize the use of aluminum, be printable on the surface, and more. However, these 12 FRs are not satisfied by 12 physical pieces. The can consists of three pieces: the body, the lid and the tab opener. There must be at least 12 DPs and they are distributed to these three pieces. Most of the DPs are associated with the geometry of the can: the thickness of the body, the curvatures at the bottom, the reduced diameter at the top to reduce the material used to make the top lid, the corrugated geometry of the tab opener to increase the stiffness, the small extrusion on the lid to attach the tab, *etc.*

The complexity is reduced when physical integration is utilized while the independence is maintained. That is, related information quantity is reduced. Therefore, physical integration does not violate the Independence Axiom. Instead, it is recommended.

2.3 The Information Axiom

2.3.1 The Calculation of Information Contents Using Probability

Axiomatic design requires satisfaction of the Independence Axiom. Multiple designs that satisfy the Independence Axiom can be derived. In this case, the best design should be selected. The best design is the one with minimum information. How can we quantitatively define the information measure? The definition varies according to the situation. Generally, the information is related to complexity. Then how can we measure complexity? We need a rigorous definition for the information content. The information content can be differently defined according to the characteristics of the design. The probability of success has been utilized as an index of the information content.

Suppose p is the probability of satisfying FR_i with DP_i . Then the information content is defined as

$$I_i = \log_2 1/p \quad (2.23)$$

In Equation 2.23, the reciprocal of p is used to make the larger probability have less information. Also, the logarithm function is utilized to enhance additivity. The base of the logarithm is 2 to express the information content with the bit unit.

Suppose we have the following uncoupled design:

$$\begin{bmatrix} FR_1 \\ FR_2 \\ FR_3 \end{bmatrix} = \begin{bmatrix} A_{11} & 0 & 0 \\ 0 & A_{22} & 0 \\ 0 & 0 & A_{33} \end{bmatrix} \begin{bmatrix} DP_1 \\ DP_2 \\ DP_3 \end{bmatrix} \quad (2.24)$$

Suppose p_1 , p_2 and p_3 are the probabilities of satisfying FR_1 , FR_2 and FR_3 with DP_1 , DP_2 and DP_3 , respectively. The total information I_{total} is

$$I_{\text{total}} = \sum_{i=1}^3 I_i = \sum_{i=1}^3 \log_2 \left(\frac{1}{p_i} \right) \quad (2.25)$$

It is noted that the information content should only be defined based on the corresponding functional requirement.

Example 2.7 [An Example of Calculating Information Content]

Information content is calculated for the design problem in Figure 2.9. It is assumed that the probability of satisfying FR_1 with DP_1 is 0.9 and the one for FR_2 with DP_2 is 0.85. The total information content is as follows:

$$I_{\text{total}} = I_1 + I_2 = \log_2 \left(\frac{1}{0.9} \right) + \log_2 \left(\frac{1}{0.85} \right) = 0.1520 + 0.2345 = 0.3865 \text{ (bits)} \quad (2.26)$$

Now the reduction of information due to physical integration is explained with Example 2.5. Without physical integration, two pieces of the two DPs should be made. If we keep the amount of material constant, the sizes of each piece should be smaller. Then the use of each piece is inconvenient and the probability of success is reduced. The result is that the information content is increased. Therefore, it is inferred that a tool with physical integration has less information content. However, not much research has been done on quantifying the reduction of information content from physical integration. We need more research on this topic.

Example 2.8 [Manufacture of a Bar with a Specified Tolerance]

Another method to calculate the probability of success is introduced. A bar of 1 m length is to be manufactured. The cases for the tolerance are ± 0.00001 m and ± 0.1 m. Calculate the information content for both cases.

Solution

If we use the same machine for both cases, the probability of success is smaller when the tolerance is small. Also, if the given length (nominal length) is longer, the ratio of the tolerance to the total length is smaller. Thus, the probability of success is as follows:

$$p = f\left(\frac{\text{tolerance}}{\text{nominal length}}\right) \quad (2.27)$$

If we assume that Equation 2.27 is linear, then it becomes as follows:

$$p = c \frac{\text{tolerance}}{\text{nominal length}} \quad (2.28)$$

where c is a constant.

Calculation of the information content for a decoupled design is somewhat different. Since independence is satisfied by the sequence of the process, the probability of success of the later process depends on that of the previous one. Therefore, it is a conditional probability. Suppose we have the following decoupled design:

$$\begin{bmatrix} FR_1 \\ FR_2 \end{bmatrix} = \begin{bmatrix} X & 0 \\ X & X \end{bmatrix} \begin{bmatrix} DP_1 \\ DP_2 \end{bmatrix} \quad (2.29)$$

If p_1 is the probability that DP_1 satisfies FR_1 , then the probability that DP_2 satisfies FR_2 under satisfaction of FR_1 by DP_1 is a conditional probability. Suppose it is p_{21} . Then the probability of success p that both FR_1 and FR_2 are satisfied is

$$p = p_1 p_{21} \quad (2.30)$$

The total information content for p is

$$I = -\log_2 p = -\log_2(p_1 p_{21}) = -\log_2 p_1 - \log_2 p_{21} = I_1 + I_2 \quad (2.31)$$

The conditional probability is useful for investigating the characteristics of the Information Axiom. However, it is rarely applied to real problems because p_{21} is not easy to evaluate. Instead, the probability density function is more practical for application.

2.3.2 Probability Density Function and Information Content

Information content can be calculated by using the probability density function. Figure 2.11 presents a schematic view of this. The terminologies are as follows: the design range is the range for the design target, the system range is the operating range of the designed product and the common range is the common area between

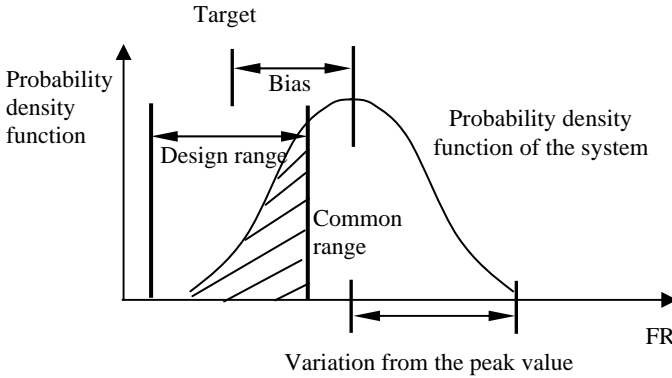

Figure 2.11. Calculation of the information content using the probability density function

the design range and the system range. The design range is defined by lower and upper bounds and the system range is defined by a distribution function of the system performance. A uniform distribution of a system range is illustrated in Figure 2.12. The design should be directed to increase the common range. The information content is defined as follows:

$$p_s = A_{cr} / A_{sr} \tag{2.32a}$$

$$I = -\log_2(A_{cr} / A_{sr}) \tag{2.32b}$$

where A_{sr} is the system range and A_{cr} is the common range.

Example 2.9 [Calculation of the Information Content Using a Probability Density Function]

A problem is made to demonstrate an example. A person defines two functional requirements to buy a house as follows:

FR_1 : Let the price range be from 50,000 dollars to 80,000 dollars.

FR_2 : Let the commuting time be within 40 minutes.

The person considers a house in city A or city B. Table 2.3 shows the conditions of both cities. Where should the person buy a house to minimize the information content?

Solution

The system range is defined from Table 2.3 and the design range is determined from the functional requirements. It is assumed that all the probability densities are uniform. Figure 2.12 presents the probability density for the price of the house in city A. Other items can be illustrated in the same manner. The information content for city A is as follows:

Table 2.3. Conditions for each city

	city A	city B
Price	\$45,000–\$60,000	\$70,000–\$90,000
Commuting time	35–50 min	20–30 min

$$I_{A1} = \log_2\left(\frac{1.5}{1}\right) = 0.59, \quad I_{A2} = \log_2\left(\frac{15}{5}\right) = 1.59 \quad (2.33)$$

$$I_A = I_{A1} + I_{A2} = 2.18 \text{ (bits)} \quad (2.34)$$

In the same manner, the information content for city B is

$$I_{B1} = \log_2\left(\frac{2}{1}\right) = 1.0, \quad I_{B2} = \log_2\left(\frac{10}{10}\right) = 0.0 \quad (2.35)$$

$$I_B = I_{B1} + I_{B2} = 1.0 \text{ (bits)} \quad (2.36)$$

The information content I_A for city A is 2.18 and that for city B I_B is 1.0. Therefore, city B has the optimum house from an axiomatic design viewpoint.

The design should be directed to reduce the information content in Equation 2.25. From Figure 2.11, it is effective to reduce the bias that is the difference between the averages of the system range and design range. After that, the standard deviation of the system range should be decreased. Then the common range is increased and the information content is reduced. This aspect is related to robust design.

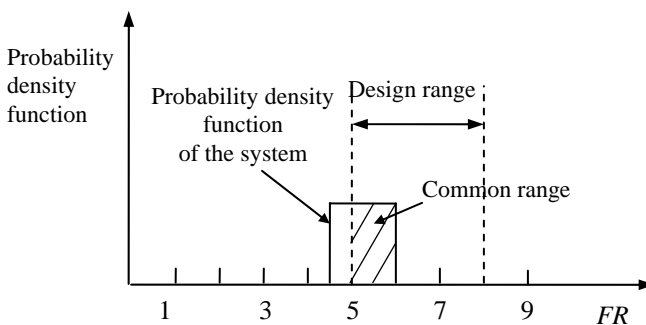
Figure 2.12. Probability density function of a uniform distribution

2.3.3 The Calculation of Information Content for a Decoupled Design

The information content for an uncoupled design is relatively easy to calculate by using Equation 2.25. Generally, the information content is not calculated for a coupled design because it violates the Independence Axiom. As mentioned earlier, the information content for a decoupled design is obtained by using the conditional probability. However, when the system range is given by the probability density function, it is not easy to use. Therefore, specific methods have been developed. There are two methods according to the distribution and the tolerance: the graphical method and the integration method. When the probability density function does not have uniform distribution or there are more than two functional requirements, the graphical method cannot be used. On the other hand, the integration method can be used in many cases, but it is difficult to use because multiple integrals should be solved.

Suppose we have the following decoupled design:

$$\begin{bmatrix} FR_1 \\ FR_2 \end{bmatrix} = \begin{bmatrix} X & 0 \\ X & X \end{bmatrix} \begin{bmatrix} DP_1 \\ DP_2 \end{bmatrix} \quad (2.37)$$

The random variation of a functional requirement (FR_i) with respect to the random variation of a design parameter (DP_i) is as follows:

$$\begin{bmatrix} \delta FR_1 \\ \delta FR_2 \end{bmatrix} = \begin{bmatrix} \frac{\partial FR_1}{\partial DP_1} & \frac{\partial FR_1}{\partial DP_2} \\ \frac{\partial FR_2}{\partial DP_1} & \frac{\partial FR_2}{\partial DP_2} \end{bmatrix} \begin{bmatrix} \delta DP_1 \\ \delta DP_2 \end{bmatrix} = \begin{bmatrix} A_{11} & 0 \\ A_{21} & A_{22} \end{bmatrix} \begin{bmatrix} \delta DP_1 \\ \delta DP_2 \end{bmatrix} \quad (2.38)$$

The random variation of design parameters is $\delta \mathbf{DP}$ and n is the number of design parameters. Suppose the tolerance ranges are $-\Delta DP_i \leq \delta DP_i \leq \Delta DP_i$, $i = 1, \dots, n$ ($0 \leq \Delta DP_i$). If the target value of the functional requirements is \mathbf{FR}^* , the success means that $\delta \mathbf{FR}$ resides within the range specified by the designer. In other words, $-\Delta FR_i \leq \delta FR_i \leq \Delta FR_i$, $i = 1, \dots, n$ ($0 \leq \Delta FR_i$) is satisfied. Suppose \mathbf{FR}^* is satisfied by \mathbf{DP}^* . If we treat the random variation as random variables, the probability of success (p_s) of the decoupled design in Equation 2.38 is as follows:

$$p_s \equiv p(-\Delta FR_1 \leq \delta FR_1 \leq \Delta FR_1) \cdot p(-\Delta FR_2 \leq \delta FR_2 \leq \Delta FR_2 \mid -\Delta FR_1 \leq \delta FR_1 \leq \Delta FR_1) \quad (2.39)$$

Let us assume that A_{ij} of Equation 2.38 is a positive constant and δDP_i is statistically independent. δFR_2 is a statistically dependent random variable with respect to δFR_1 . In the DP domain, the condition in Equation 2.39 can be expressed as

$$-\Delta FR_1 \leq A_{11} \delta DP_1 \leq \Delta FR_1 \quad (2.40a)$$

$$-\Delta FR_2 \leq A_{21} \delta DP_1 + A_{22} \delta DP_2 \leq \Delta FR_2 \quad (2.40b)$$

$$-\Delta DP_1 \leq \delta DP_1 \leq \Delta DP_1 \quad (2.40c)$$

$$-\Delta DP_2 \leq \delta DP_2 \leq \Delta DP_2 \quad (2.40d)$$

Equation 2.40 can be mapped into the FR domain as follows:

$$-\Delta FR_1 \leq \delta FR_1 \leq \Delta FR_1 \quad (2.41a)$$

$$-\Delta FR_2 \leq \delta FR_2 \leq \Delta FR_2 \quad (2.41b)$$

$$-A_{11} \Delta DP_1 \leq \delta FR_1 \leq A_{11} \Delta DP_1 \quad (2.41c)$$

$$-A_{22} \Delta DP_2 \leq \delta FR_2 - \frac{A_{21}}{A_{11}} \delta FR_1 \leq A_{22} \Delta DP_2 \quad (2.41d)$$

If A_{ij} is negative, Equation 2.41 can be different.

The range of δDP satisfying Equation 2.40 is the range satisfying Equation 2.39. In the same manner, the range of δFR satisfying Equation 2.41 satisfies Equation 2.39. This is similar to the feasible region of the optimization theory. That is, if we obtain the probability density function in the feasible region of Equation 2.40 or 2.41, then the probability of Equation 2.39 is calculated.

In the graphical method, the area of the feasible region is calculated from Equation 2.40 or 2.41. It is utilized when the probability density functions of the FRs or DPs are uniform. Figure 2.13 represents the range satisfying Equation 2.40. The probability of success and the information content are as follows:

$$p_s = A_f / A_{dp} \quad (2.42a)$$

$$I = -\log_2 p_s \quad (2.42b)$$

where A_f is the feasible region, which is the shadowed area in Figure 2.13 and A_{dp} is the tolerance for design parameters, which is $4\Delta DP_1 \Delta DP_2$ in Figure 2.13.

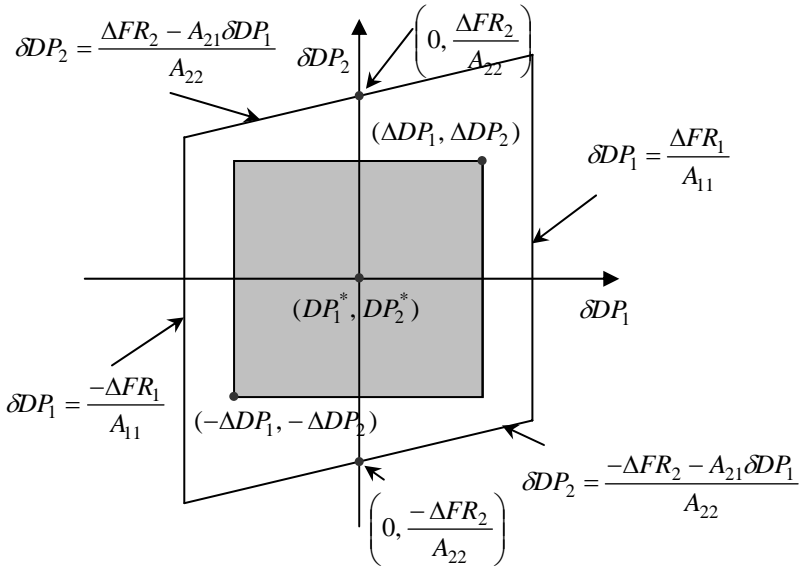

(a) When the probability of success = 1

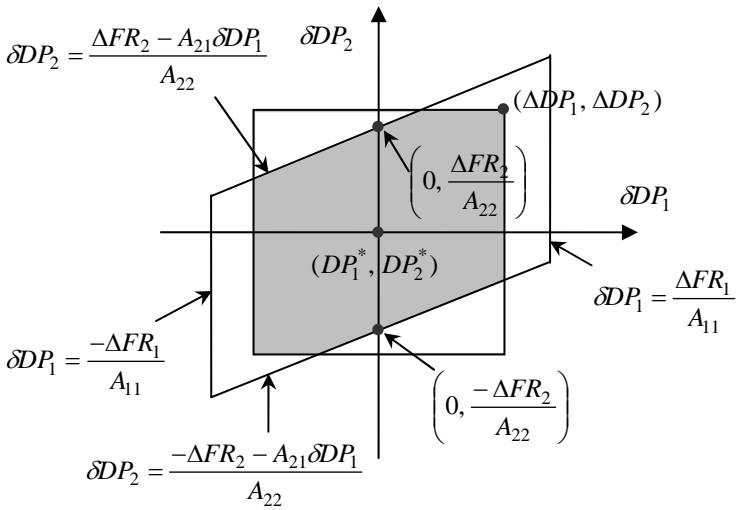

(b) When the probability of success < 1

Figure 2.13. The probability of success of the decoupled design in the DP range

The graphical method in the FR domain is illustrated in Figure 2.14. In the functional domain, the system range, the design range and the common range are defined. In the same manner as Equation 2.32, the probability of success and the information content are defined as follows:

$$p_s = A_{cr} / A_{sr} \quad (2.43a)$$

$$I = -\log_2 p_s \quad (2.43b)$$

where A_{sr} is the area of the system range, which is the area of the parallelogram in Figure 2.14 and the design range is the shadowed area of Figure 2.14. The common range A_{cr} is the common area of the system range and the design range. This is the same as the feasible region in Equation 2.41. It is noted that the probability of success for Figure 2.13a is 1, but that for Figure 2.14a is not 1. It is somewhat complicated to calculate the shadowed area in Figure 2.13b or the common area of Figure 2.14b. The probability of success for Figure 2.14b is as follows:

$$p_s = \frac{\Delta FR_1}{A_{11}\Delta DP_1} - \frac{\frac{A_{11}}{A_{21}} \left(\frac{A_{21}}{A_{11}} \Delta FR_1 + A_{22} \Delta DP_2 - \Delta FR_2 \right)^2}{4A_{11}\Delta DP_1 \cdot A_{22}\Delta DP_2} \quad (2.44)$$

The probability of success can also be calculated by multiple integration. It is conducted in the DP domain. As mentioned earlier, the probability of success is evaluated for the feasible region, which is the shadowed area in Figure 2.13. Suppose $p_{\delta DP_1}$ and $p_{\delta DP_2}$ are the distribution functions of δDP_1 and δDP_2 , respectively. Then the probability density function in the feasible region Ω (probability of success) is

$$\iint_{\Omega} p_{\delta DP_1} p_{\delta DP_2} d\delta DP_2 d\delta DP_1 \quad (2.45)$$

When the feasible region is such as the one in Figure 2.13a, the integration is easy. However, if it is such as the one in Figure 2.13b, the integration is somewhat more difficult. In that case, we employ the unit step function $u(x)$ as follows:

$$\begin{aligned} u(x - x^*) &= 1 : \text{when } x \geq x^* \\ &= 0 : \text{when } x < x^* \end{aligned} \quad (2.46)$$

Figure 2.15 represents the unit step function. Using the unit step function, the probability distribution can be defined not only in the feasible region but also in the entire region as follows:

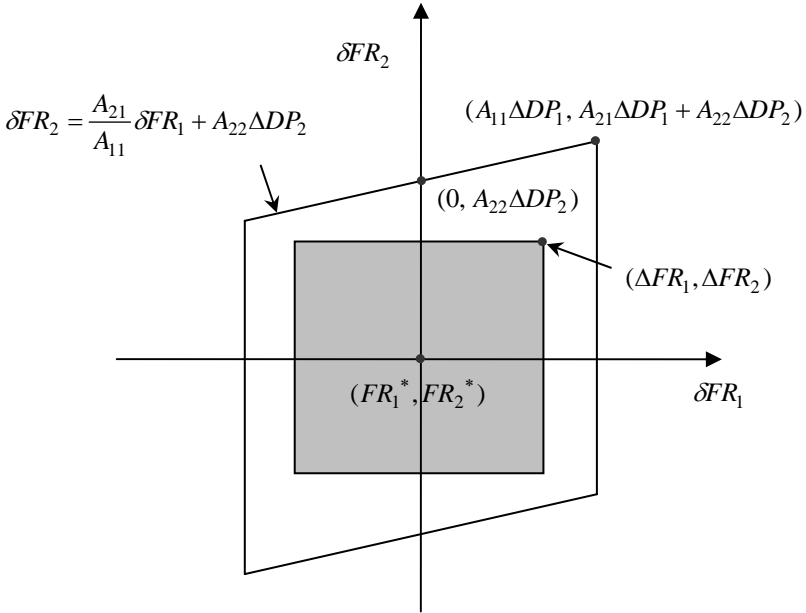

(a) The design range resides within the system range

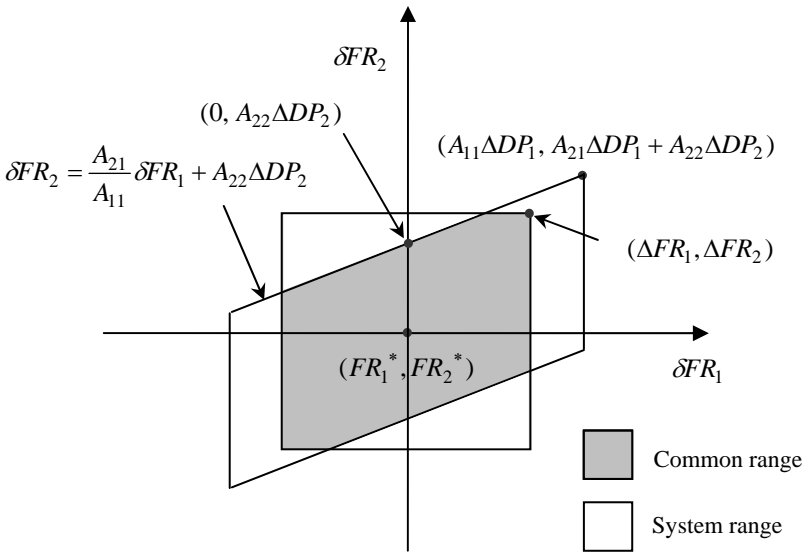

(b) The design range crosses the system range

Figure 2.14. The probability of success of a decoupled design in the FR range

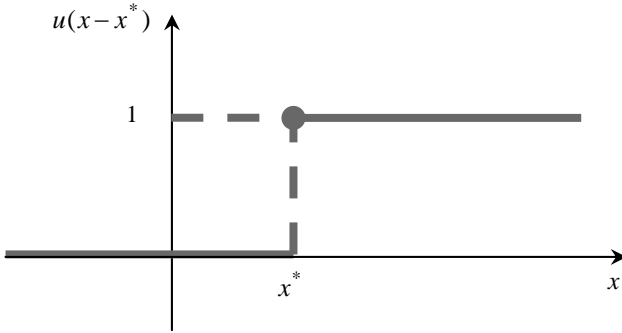

Figure 2.15. Unit step function

$$p_1 = p_{\delta DP_1} \cdot [u(\delta DP_1 - (-\Delta DP_1)) - u(\delta DP_1 - \Delta DP_1)] \quad (2.47a)$$

$$p_2 = p_{\delta DP_2} \cdot [u(\delta DP_2 - (-\Delta DP_2)) - u(\delta DP_2 - \Delta DP_2)] \quad (2.47b)$$

To integrate in the feasible region, the parallelograms in Figure 2.13 are used as the integration interval. The interval is

$$\left(\frac{-\Delta FR_1}{A_{11}} \leq \delta DP_1 \leq \frac{\Delta FR_1}{A_{11}}, \quad \frac{-\Delta FR_2 - A_{21}\delta DP_1}{A_{22}} \leq \delta DP_2 \leq \frac{\Delta FR_2 - A_{21}\delta DP_1}{A_{22}} \right) \quad (2.48)$$

Since p_1 and p_2 are statistically independent, the probability of success is

$$\int_{\frac{-\Delta FR_1}{A_{11}}}^{\frac{\Delta FR_1}{A_{11}}} \int_{\frac{-\Delta FR_2 - A_{21}\delta DP_1}{A_{22}}}^{\frac{\Delta FR_2 - A_{21}\delta DP_1}{A_{22}}} p_1 p_2 \, d\delta DP_2 \, d\delta DP_1 \quad (2.49)$$

In some cases, we may not satisfy the target value \mathbf{FR}^* exactly with the design parameters. In this case, the following equations hold:

$$\mathbf{FR}_c = \mathbf{ADP}_c \quad (2.50a)$$

$$\mathbf{FR}_c \neq \mathbf{FR}^* \quad (2.50b)$$

where $\mathbf{DP}_c = [DP_{c1}, DP_{c2}]^T$ and \mathbf{FR}_c is the functional requirement vector made by the current design parameters. The probability of success by the graphical method is evaluated by transition of the rectangulars and parallelograms in Figures 2.13 and 2.14, so that $\mathbf{DP}_c = [DP_{c1}, DP_{c2}]^T$ becomes the origin. Then Equation 2.40 yields

$$FR_1^* - \Delta FR_1 \leq A_{11}(DP_{c1} + \delta DP_1) \leq FR_1^* + \Delta FR_1 \tag{2.51a}$$

$$FR_2^* - \Delta FR_2 \leq A_{21}(DP_{c1} + \delta DP_1) + A_{22}(DP_{c2} + \delta DP_2) \leq FR_2^* + \Delta FR_2 \tag{2.51b}$$

$$-\Delta DP_1 \leq \delta DP_1 \leq \Delta DP_1 \tag{2.51c}$$

$$-\Delta DP_2 \leq \delta DP_2 \leq \Delta DP_2 \tag{2.51d}$$

The probability distributions p_1 and p_2 in Equation 2.47 can be directly used. Using Equations 2.47 and 2.51, the probability of success is calculated as follows:

$$\frac{\int_{A_{11}}^{FR_1^* - A_{11}DP_{c1} + \Delta FR_1} \int_{A_{22}}^{FR_2^* - A_{21}DP_{c1} - A_{22}DP_{c2} + \Delta FR_2 - A_{21}\delta DP_1} p_1 p_2 d\delta DP_2 d\delta DP_1}{\int_{A_{11}}^{FR_1^* - A_{11}DP_{c1} - \Delta FR_1} \int_{A_{22}}^{FR_2^* - A_{21}DP_{c1} - A_{22}DP_{c2} - \Delta FR_2 - A_{21}\delta DP_1}} \tag{2.52}$$

The advantage of the integration method is that the probability of success can be calculated for many design parameters. If the number of design parameters is n , the following multiple integration is utilized:

$$\frac{\int_{A_{11}}^{FR_1^* - A_{11}DP_{c1} + \Delta FR_1} \dots \int_{A_{mm}}^{FR_n^* - \sum_{i=1}^n A_{ni}DP_{ci} + \Delta FR_n - \sum_{i=1}^{n-1} A_{ni}\delta DP_i} p_1 \dots p_n d\delta DP_n \dots d\delta DP_1}{\int_{A_{11}}^{FR_1^* - A_{11}DP_{c1} - \Delta FR_1} \dots \int_{A_{mm}}^{FR_n^* - \sum_{i=1}^n A_{ni}DP_{ci} - \Delta FR_n - \sum_{i=1}^{n-1} A_{ni}\delta DP_i}} \tag{2.53}$$

The integration method can be defined by the distribution function of FR for the feasible region in Equation 2.41. Calculation of the information content in the FR domain is more complicated than calculation in the DP domain, because the distribution of DP is usually given.

The above methods can be applied to designs with FR–DP hierarchy of many levels. When we have multilevel hierarchy, we can make an entire design matrix for the FRs and DPs in the lowest level. We can apply the above methods to the entire design matrix. The information content can be evaluated for a coupled design. The method is defined by modification of the above methods. However, it

is very complex and the coupled design is not considered in general design. Therefore, the information content for the coupled design is not explained here.

Example 2.10 [Calculation of Information Content for a Decoupled Design–1]

We have the following decoupled design:

$$\begin{bmatrix} FR_1 \\ FR_2 \end{bmatrix} = \begin{bmatrix} 3 & 0 \\ 2 & 5 \end{bmatrix} \begin{bmatrix} DP_1 \\ DP_2 \end{bmatrix} \quad (2.54)$$

where $\begin{bmatrix} DP_1^* \\ DP_2^* \end{bmatrix} = \begin{bmatrix} 1 \\ 1 \end{bmatrix}$, $\begin{bmatrix} FR_1^* \\ FR_2^* \end{bmatrix} = \begin{bmatrix} 3 \\ 7 \end{bmatrix}$ and the tolerances for design parameters are $\Delta DP_1 = 0.3$ and $\Delta DP_2 = 0.3$, and the allowable tolerance is $\Delta FR = 1.5$. δDP_i has uniform distribution in the tolerance range.

- (1) Calculate the information content in the DP domain by using the graphical method.
- (2) Calculate the information content in the FR domain by using the graphical method.
- (3) Calculate the information content in the DP domain by using the integration method.

Solution

- (1) From Equation 2.40, the feasible region in the DP domain is as follows:

$$-1.5 \leq 3\delta DP_1 \leq 1.5 \quad (2.55a)$$

$$-1.5 \leq 2\delta DP_1 + 5\delta DP_2 \leq 1.5 \quad (2.55b)$$

$$-0.3 \leq \delta DP_1 \leq 0.3 \quad (2.55c)$$

$$-0.3 \leq \delta DP_2 \leq 0.3 \quad (2.55d)$$

Equation 2.55 is illustrated in Figure 2.16. From Equation 2.42, the probability of success and the information content are

$$p_s = \frac{A_f}{A_{dp}} = \frac{0.6 \times 0.6 - 0.3 \times 0.12 \times 0.5 \times 2}{0.6 \times 0.6} = 0.9 \quad (2.56a)$$

$$I = \log_2 \frac{1}{p_s} = 0.152 \text{ (bits)} \quad (2.56b)$$

- (2) From Equation 2.41, the feasible region in the FR domain is as follows:

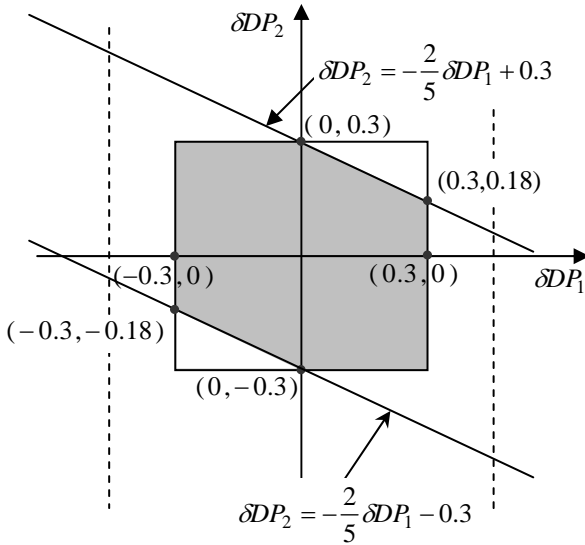

Figure 2.16. Graphical presentation of Example 2.10(1) in the DP range

$$-1.5 \leq \delta FR_1 \leq 1.5 \tag{2.57a}$$

$$-1.5 \leq \delta FR_2 \leq 1.5 \tag{2.57b}$$

$$-3 \times 0.3 \leq \delta FR_1 \leq 3 \times 0.3 \tag{2.57c}$$

$$-5 \times 0.3 \leq \delta FR_2 - \frac{2}{3} \delta FR_1 \leq 5 \times 0.3 \tag{2.57d}$$

Equation 2.57 is illustrated in Figure 2.17. From Equation 2.43, the probability of success and the information content are

$$p_s = \frac{A_{cr}}{A_{sr}} = \frac{1.8 \times 3 - 0.9 \times 0.6 \times 0.5 \times 2}{1.8 \times 3} = 0.9 \tag{2.58a}$$

$$I = \log_2 \frac{1}{p_s} = 0.152 \text{ (bits)} \tag{2.58b}$$

(3) From Equation 2.47,

$$p_{\delta DP_1} = p_{\delta DP_2} = \frac{1}{2 \Delta DP_1} = \frac{1}{0.6} \tag{2.59a}$$

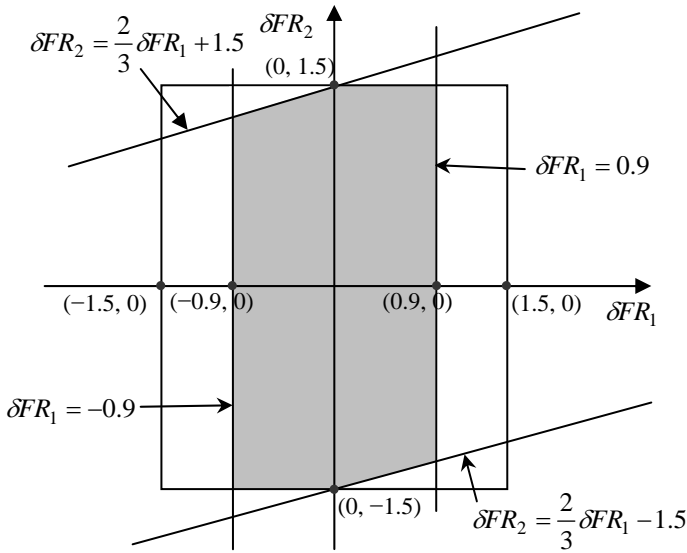

Figure 2.17. Graphical presentation of Example 2.10(2) in the FR range

$$p_i = 1.667 \times (u(\delta DP_i - (-0.3)) - u(\delta DP_i - 0.3)), \quad i = 1, 2 \quad (2.59b)$$

From Equation 2.49, the probability of success and the information content are

$$p_s = \int_{\frac{1.5}{3}}^{\frac{1.5-2\delta DP_1}{5}} \int_{\frac{1.5-1.5-2\delta DP_1}{3}}^{\frac{5}{5}} p_1 p_2 d\delta DP_2 d\delta DP_1 = 0.9 \quad (2.60a)$$

$$I = \log_2 \frac{1}{p_s} = 0.152 \text{ (bits)} \quad (2.60b)$$

Example 2.11 [Calculation of Information Content for a Decoupled Design–2]

When $\begin{bmatrix} DP_{c1} \\ DP_{c2} \end{bmatrix} = \begin{bmatrix} 0.9 \\ 1.1 \end{bmatrix}$ in Equation 2.54, the allowable tolerance for the functional

requirement is $FR_i^* - \Delta FR_i \leq FR_i \leq FR_i^* + \Delta FR_i$. $\begin{bmatrix} FR_1^* \\ FR_2^* \end{bmatrix} = \begin{bmatrix} 3 \\ 7 \end{bmatrix}$ and $\Delta FR_i = 1.5$,

$i = 1, 2$. The tolerance and distribution are the same as in Example 2.10.

- (1) Calculate the information content in the DP range by using the graphical method.
- (2) Calculate the information content in the FR range by using the graphical method.
- (3) Calculate the information content in the DP domain by using the integration method.

Solution

- (1) Equation 2.40 is modified to

$$FR_1^* - \Delta FR_1 \leq A_{11}(DP_{c1} + \delta DP_1) \leq FR_1^* + \Delta FR_1 \quad (2.61a)$$

$$FR_2^* - \Delta FR_2 \leq A_{21}(DP_{c1} + \delta DP_1) + A_{22}(DP_{c2} + \delta DP_2) \leq FR_2^* + \Delta FR_2 \quad (2.61b)$$

$$-\Delta DP_1 \leq \delta DP_1 \leq \Delta DP_1 \quad (2.61c)$$

$$-\Delta DP_2 \leq \delta DP_2 \leq \Delta DP_2 \quad (2.61d)$$

Equation 2.61 becomes

$$3 - 1.5 \leq 3(0.9 + \delta DP_1) \leq 3 + 1.5 \quad (2.62a)$$

$$7 - 1.5 \leq 2(0.9 + \delta DP_1) + 5(1.1 + \delta DP_2) \leq 7 + 1.5 \quad (2.62b)$$

$$-0.3 \leq \delta DP_1 \leq 0.3 \quad (2.62c)$$

$$-0.3 \leq \delta DP_2 \leq 0.3 \quad (2.62d)$$

Equation 2.62 is illustrated in Figure 2.18. The probability of success and the information content are

$$p_s = \frac{0.6 \times 0.6 - (0.18 \times 0.45 \times 0.5 + 0.15 \times 0.06 \times 0.5)}{0.6 \times 0.6} = 0.875 \quad (2.63a)$$

$$I = \log_2 \frac{1}{p_s} = 0.193 \text{ (bits)} \quad (2.63b)$$

- (2) Equation 2.41 is modified to

$$\begin{bmatrix} FR_{c1} \\ FR_{c2} \end{bmatrix} = \begin{bmatrix} 3 & 0 \\ 2 & 5 \end{bmatrix} \begin{bmatrix} DP_{c1} \\ DP_{c2} \end{bmatrix} = \begin{bmatrix} 2.7 \\ 7.3 \end{bmatrix} \quad (2.64a)$$

$$FR_1^* - \Delta FR_1 \leq FR_{c1} + \delta FR_1 \leq FR_1^* + \Delta FR_1 \quad (2.64b)$$

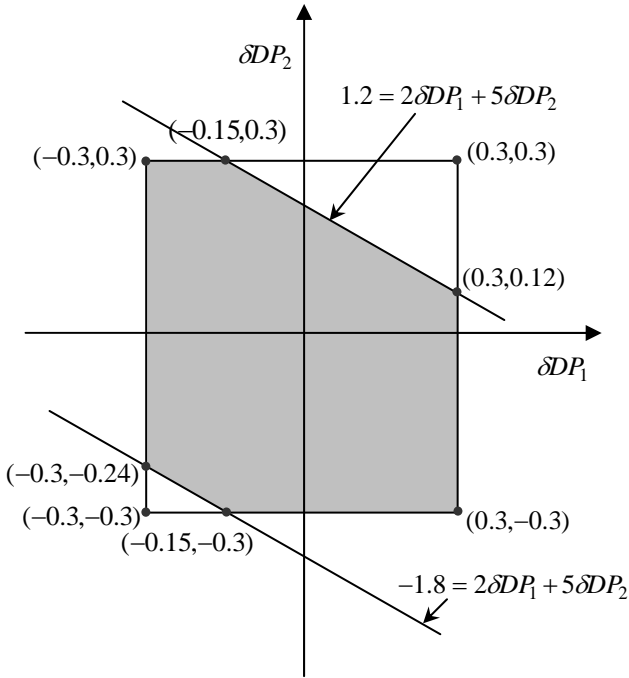

Figure 2.18. Graphical presentation of Example 2.11(1) in the DP range

$$FR_2^* - \Delta FR_2 \leq FR_{c2} + \delta FR_2 \leq FR_2^* + \Delta FR_2 \quad (2.64c)$$

$$-A_{11}\Delta DP_1 \leq \delta FR_1 \leq A_{11}\Delta DP_1 \quad (2.64d)$$

$$-A_{22}\Delta DP_2 \leq \delta FR_2 - \frac{A_{21}}{A_{11}}\delta FR_1 \leq A_{22}\Delta DP_2 \quad (2.64e)$$

Equation 2.64 becomes

$$-1.2 \leq \delta FR_1 \leq 1.8 \quad (2.65a)$$

$$-1.8 \leq \delta FR_2 \leq 1.2 \quad (2.65b)$$

$$-0.9 \leq \delta FR_1 \leq 0.9 \quad (2.65c)$$

$$-1.5 \leq \delta FR_2 - \frac{2}{3}\delta FR_1 \leq 1.5 \quad (2.65d)$$

Equation 2.65 is illustrated in Figure 2.19. The probability of success and the information content are

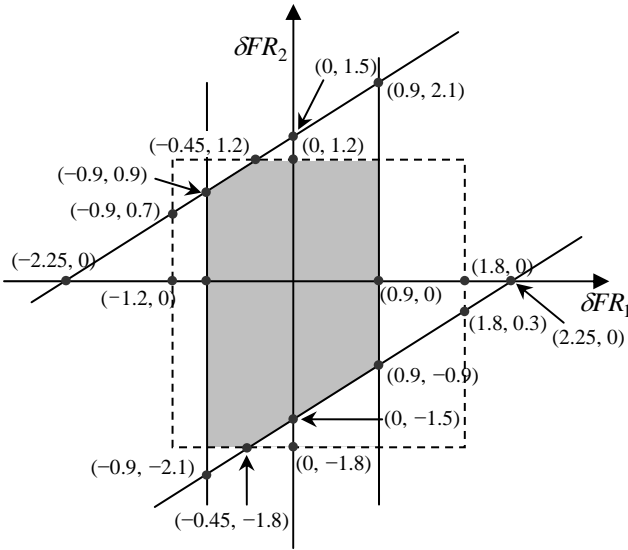

Figure 2.19. Graphical presentation of Example 2.10(2) in the FR range

$$p_s = \frac{A_{cr}}{A_{sr}} = \frac{1.8 \times 3 - (0.45 \times 0.3 \times 0.5 + 1.35 \times 0.9 \times 0.5)}{1.8 \times 3} = 0.875 \quad (2.66a)$$

$$I = \log_2 \frac{1}{p_s} = 0.193 \text{ (bits)} \quad (2.66b)$$

(3) The integration range is within the parallelogram in Figure 2.18. Therefore, the information content is calculated as

$$p_s = \int_{-0.4}^{0.6} \int_{\frac{-1.8-2\delta DP_1}{5}}^{\frac{1.2-2\delta DP_1}{5}} p_1 p_2 d\delta DP_2 d\delta DP_1 = 0.875 \quad (2.67)$$

where p_1 and p_2 are the same as those in Equation 2.59.

Example 2.12 [Calculation of Information Content for a Decoupled Design–3]

The distribution function $p_{\delta DP_i}$ for Equation 2.54 is as follows:

$$p_{\delta DP_i} = -\frac{3}{4(\Delta DP_i)^3} (\delta DP_i)^2 + \frac{3}{4(\Delta DP_i)}, \quad i = 1, 2 \quad (2.68)$$

- (1) In Example 2.10, replace the distribution function with Equation 2.68. The tolerances for the design parameters are the same. Calculate the probability of success by the integration method.
- (2) In Example 2.11, replace the distribution function with Equation 2.68. The tolerances for the design parameters are the same. Calculate the probability of success by the integration method.

Solution

- (1) When the distribution has Equation 2.68 in Example 2.10, the probability distribution p_i for the i th design parameter is

$$p_i = \left[\frac{-3}{4 \times 0.3^3} (\delta DP_i)^2 + \frac{3}{4 \times 0.3} \right] \times [u(\delta DP_i - (-\Delta DP_i)) - u(\delta DP_i - (\Delta DP_i))] \quad (2.69)$$

By substituting Equation 2.69 into Equation 2.59, the probability of success and the information content are calculated by the following multiple integrations:

$$p_s = \int_{\frac{1.5}{3}}^{\frac{1.5-2\delta DP_1}{5}} \int_{\frac{1.5-1.5-2\delta DP_1}{3}}^{\frac{5}{5}} p_1 p_2 d\delta DP_2 d\delta DP_1 = 0.978 \quad (2.70a)$$

$$I = \log_2 \frac{1}{p_s} = 0.032 \text{ (bits)} \quad (2.70b)$$

- (2) When the distribution is as in Equation 2.68 in Example 2.11, Equations 2.69 and 2.70 are used directly. The probability of success and the information content are as follows:

$$p_s = \int_{-0.4}^{0.6} \int_{\frac{1.2-2\delta DP_1}{5}}^{\frac{5}{5}} p_1 p_2 d\delta DP_2 d\delta DP_1 = 0.953 \quad (2.71a)$$

$$I = \log_2 1 / p_s = 0.07 \text{ (bits)} \quad (2.71b)$$

The example shows various cases for calculating the information content using the probability density function. A practical example is introduced in Appendix 2.B.

2.4 The Application of Axiomatic Design

In most cases, the information content is reduced if the Independence Axiom is satisfied. Therefore, it seems that the Information Axiom is dependent on the Independence Axiom and the Information Axiom is not required. However, some particular cases can exist. Suppose we find an uncoupled design and a coupled design that satisfy the given functional requirements. In some cases, the information content of the coupled design may be smaller than that of the uncoupled design. Then the question arises can the coupled design be better than the uncoupled one? The answer is “no.” Actually, this indicates that there should be an uncoupled or a decoupled design that has less information content than the coupled design. Therefore, the designer should make an effort to find an uncoupled or decoupled design. The designer may find multiple uncoupled or decoupled designs. If they are the same in satisfying the Independence Axiom, one should select the one with the minimum information content. The flow chart to apply the two axioms is illustrated in Figure 2.20. Appendix 2.B demonstrates a typical example for the flow of Figure 2.20.

We will investigate how axiomatic design is applied to a practical design. Generally, it is applied to the following areas:

- (1) Creative design.
- (2) Analysis of existing designs.
- (3) Design improvement.

Suppose that new functional requirements are defined and that there is no product that satisfies the functional requirements. The designer will try to find a new design. In this case, a creative designer generally creates a new idea for a new product. Axiomatic design can be exploited to materialize the design idea. The idea is analyzed and selection and allocation of parts are determined by the axiomatic approach. However, the creation of an entirely new idea is very difficult and rare in machine design. Therefore, considerable improvement of an existing design is regarded as a creative design.

Generally, a survey of public opinion can be conducted to evaluate an existing product. However, axiomatic design can be utilized for evaluation from the viewpoint of designers. In particular, different products for the same goal can be evaluated. The goals of the product are the functional requirements. We can select a better product that satisfies the Independence Axiom. If multiple products satisfy the Independence Axiom in the same manner, we can select the best one from the Information Axiom.

Finally, axiomatic design can be used to improve the current design. When the current design is not sufficiently good or an improved design is needed, the Independence Axiom is used first. The FRs and DPs are defined and satisfaction of the Independence Axiom is checked with them. If the Independence Axiom is not satisfied, an improved design should be made to satisfy the Independence Axiom. When the Independence Axiom is satisfied, the DPs are defined to minimize the information content.

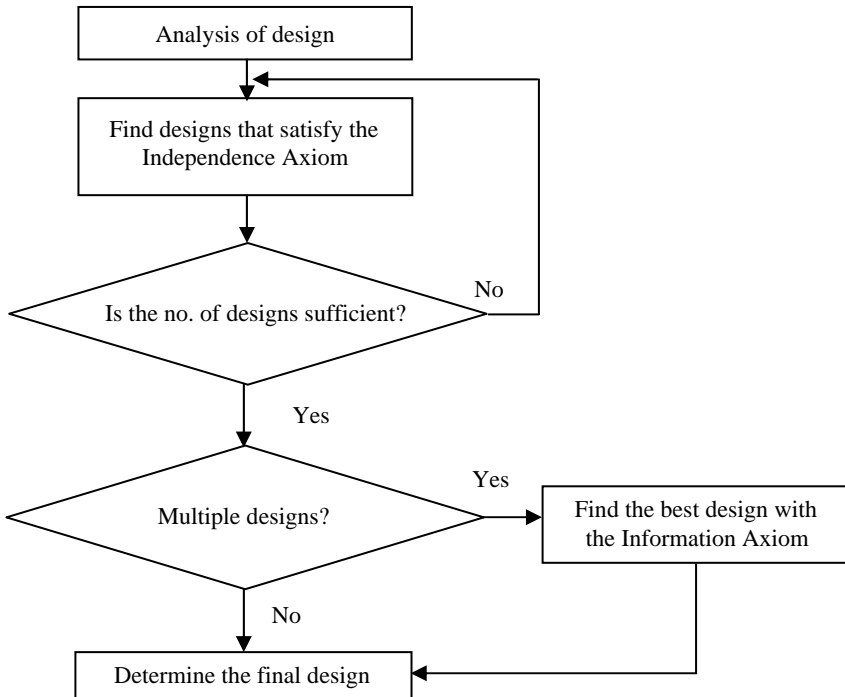

Figure 2.20. Flow chart of the application of axiomatic design

Example 2.13 [An Example of a Creative Design: Refrigerator Design]
(Lee *et al.* 1994)

The example of the design of a refrigerator is introduced. In a general refrigerator, food is frozen for long-term preservation and is maintained at a cold temperature for short-term preservation. The following two functional requirements are defined:

FR_1 : Freeze food for long-term preservation.

FR_2 : Maintain food at a cold temperature for short-term preservation.

To satisfy the two FRs, a refrigerator with two compartments can be designed. The design parameters are as follows:

DP_1 : The freezer section

DP_2 : The chiller section

The design matrix in the first level is diagonal; therefore, it is an uncoupled design. FR_1 can be decomposed by the selection of DP_1 .

FR_{11} : Maintain the temperature of the freezer section in the range of $-18^{\circ}\text{C} \pm 2^{\circ}\text{C}$.

FR_{12} : Maintain a uniform temperature in the freezer section.

FR_{13} : Control the relative humidity to 50% in the freezer section.

In the same manner, FR_2 can be decomposed with respect to DP_2 .

FR_{21} : Maintain the temperature of the chiller section in the range of $2^{\circ}\text{C} - 3^{\circ}\text{C}$.

FR_{22} : Maintain a uniform temperature in the chiller section within $\pm 0.5^{\circ}\text{C}$ of the preset temperature.

The design parameters for the second level are to be determined. The DPs must be determined to satisfy the independence of the FRs. It is noted that DPs in the lower level should be determined so as not to violate the independence of the upper level.

The FRs of the freezer section can be satisfied by (1) a device pumping chilled air into the freezer section, (2) a device for circulation of air for a uniform temperature, (3) a monitoring device to independently control the temperature and humidity. Therefore, the DPs in the second level are defined as follows:

DP_{11} : Sensor/compressor system that activates the compressor when the temperature of the freezer section is different from the preset one

DP_{12} : Air circulation system that blows the air into the freezer and circulates it uniformly

DP_{13} : Condenser that condenses the moisture in the returned air when the dew point is exceeded

The design is a decoupled one as follows:

$$\begin{bmatrix} FR_{12} \\ FR_{11} \\ FR_{13} \end{bmatrix} = \begin{bmatrix} X & 0 & 0 \\ X & X & 0 \\ X & 0 & X \end{bmatrix} \begin{bmatrix} DP_{12} \\ DP_{11} \\ DP_{13} \end{bmatrix} \quad (2.72)$$

For food storage in the chiller section, the temperature should be maintained in the range of $2^{\circ}\text{C} - 3^{\circ}\text{C}$. The chiller section also activates the compressor and circulates the air. Design parameters for the chiller section are

DP_{21} : Sensor/compressor system that activates the compressor when the temperature of the chiller section is different from the preset one

DP_{22} : Air circulation system that blows the air into the chiller section and circulates it uniformly

The design equation is a decoupled one as follows:

$$\begin{bmatrix} FR_{22} \\ FR_{21} \end{bmatrix} = \begin{bmatrix} X & 0 \\ X & X \end{bmatrix} \begin{bmatrix} DP_{22} \\ DP_{21} \end{bmatrix} \tag{2.73}$$

The entire design equation decomposed up to the second level is a decoupled one as follows:

$$\begin{bmatrix} FR_{12} \\ FR_{11} \\ FR_{13} \\ FR_{22} \\ FR_{21} \end{bmatrix} = \begin{bmatrix} X & 0 & 0 & 0 & 0 \\ X & X & 0 & 0 & 0 \\ X & 0 & X & 0 & 0 \\ 0 & 0 & 0 & X & 0 \\ 0 & 0 & 0 & X & X \end{bmatrix} \begin{bmatrix} DP_{12} \\ DP_{11} \\ DP_{13} \\ DP_{22} \\ DP_{21} \end{bmatrix} \tag{2.74}$$

It is noted that the FRs of the lower level still keep the independence of the upper level in Equation 2.74.

From the design equation in Equation 2.74, one compressor and two fans can satisfy the FRs. DP_{11} and DP_{21} are sensor/compressor systems so that the compressor is activated by the sensors. However, the fans of DP_{12} and DP_{22} will not be activated unless the temperature is out of the range of the preset one. Therefore, the design with one compressor and two fans satisfies the Independence Axiom. An example is illustrated in Figure 2.21. Other designs can be proposed. If multiple designs are proposed, we can select one that satisfies the Independence Axiom and controls the temperature and humidity in a wide range. The new design and the conventional refrigerator are compared.

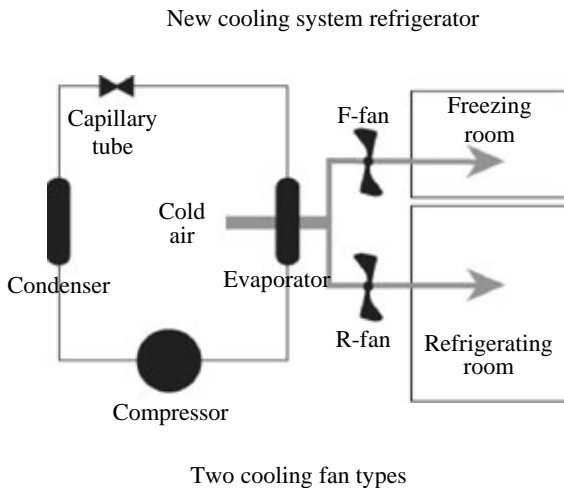

Figure 2.21. A new design of a refrigerator that satisfies the Independence Axiom

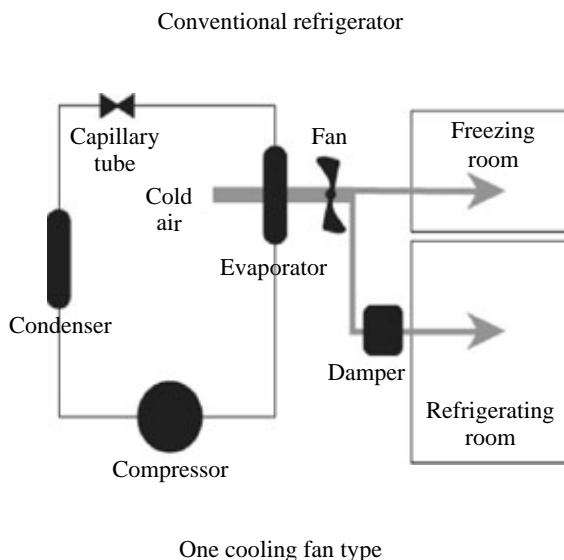

Figure 2.22. Conventional refrigerator

The conventional refrigerator consists of one compressor and one fan. As illustrated in Figure 2.22, a damper is utilized to cool the refrigerating room. Therefore, the temperature of the refrigerator is not independently controlled. When the temperature exceeds 3°C , the damper is opened. However FR_{21} is not satisfied unless the compressor and the fan of the freezer section are activated.

According to Corollary 2.3 of Appendix 2.A, if we can satisfy the FRs with one fan, the design in Figure 2.21 may not be the best. If we can find another design that satisfies the Independence Axiom, we have to apply the Information Axiom to select the best one.

Example 2.14 [An Example of Analysis of Existing Designs: Liquid Crystal Display Holder] (NSF 1998, Suh 2000)

The liquid crystal display (LCD) is a projection display system. Three LCD panels project the red, green and blue images of a TV signal. The configuration of an LCD projector is illustrated in Figure 2.23. To display an exact color image by an LCD projection system, the three panels should be aligned with respect to the blue image within a tolerance value.

To align the pixels, the projector uses a device that can control the rotation and translation of the LCD panels. The pixels of one of the three panels are set as a reference, and the remaining two panels are properly aligned. Each LCD panel is attached to an adjusting mechanism, which is called an “LCD holder.” For alignment of the pixels, at least two LCD holders should have three degrees of

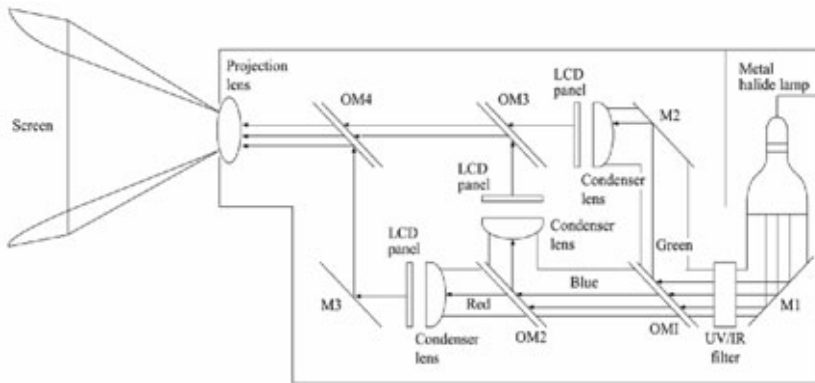

Figure 2.23. Schematic view of an LCD projector

freedom (translation along the X and Y axes and rotation with respect to the Z axis). Two products manufactured by Sanyo and Sharp will be compared.

Based on the Independence Axiom, we will select the better one.

Solution

The *FR* and *DP* of the highest level are stated as follows:

FR : Align the pixels of the LCD panels.

DP : The LCD holder that can align the pixels of the LCD panels

To align the pixels of all the LCD panels, the functional requirement is decomposed as follows:

*FR*₁ : Translate along the X axis = $T(X)$.

*FR*₂ : Translate along the Y axis = $T(Y)$.

*FR*₃ : Rotate with respect to the Z axis = $R(Z)$.

The LCD projector uses three panels, and one is used as a reference one. Therefore, holders with three degrees of freedom are needed for the two panels.

Sanyo Holder

Figure 2.24 shows the Sanyo holder. The holder is composed of three mechanisms and is attached to each panel of Figure 2.23. All of them are lead screw structures. If a screw moves, the attached plane moves accordingly. plate A is fixed to the side frame. The LCD panel is attached to plate C. The three lead screws are design parameters.

*DP*₁ : The lead screw for conjunction of plate B and screw 1

*DP*₂ : The lead screw for conjunction of plate C and screw 2

*DP*₃ : The lead screw for conjunction of plate B and screw 3

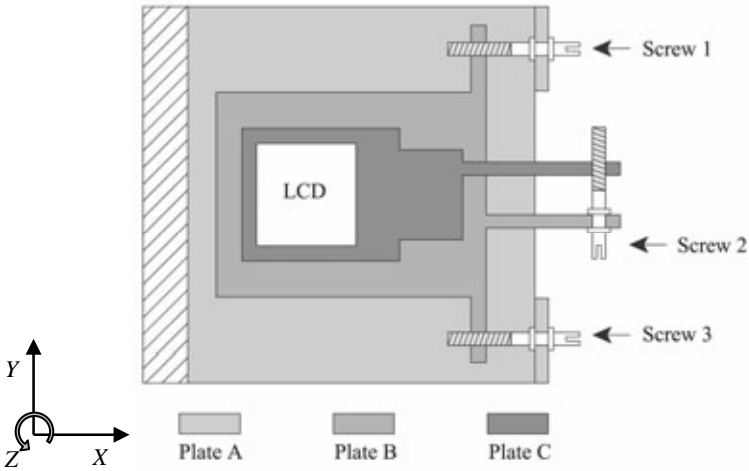

Figure 2.24. The Sanyo LCD holder mechanism

If plate B is rotated, the LCD panel moves along the $T(X)$ and $R(Z)$ axes. Plate C and the LCD panel move with plate B. If screw 1 is rotated, the LCD panel moves in $T(X)$ and $R(Z)$. Therefore, DP_1 affects FR_1 and FR_3 . DP_2 is composed of screw 2 and plate C. If screw 2 is rotated, plate C and the LCD panel move in the Y direction. Since the rotation of screw 2 changes the position of the LCD panel in the $T(X)$ axis, DP_2 only affects FR_2 . DP_3 has the same function as DP_1 . The rotation of screw 3 moves the LCD panel in the $T(X)$ and $R(Z)$ axes and DP_3 affects FR_1 and FR_3 . The design equation is

$$\begin{bmatrix} T(X) \\ T(Y) \\ R(Z) \end{bmatrix} = \begin{bmatrix} X & 0 & X \\ 0 & X & 0 \\ X & 0 & X \end{bmatrix} \begin{bmatrix} DP_1 \\ DP_2 \\ DP_3 \end{bmatrix} \quad (2.75)$$

Because the design matrix in Equation 2.75 is coupled, it violates the Independence Axiom.

With this product, repeated adjustment should be conducted to align the pixels. For example, when the angle should be changed, DP_1 can be changed. However, DP_1 changes the position of the LCD panel in the X direction and an undesirable error occurs. Because we do not have a DP that only affects FR_1 , a repeated process with trial and error is needed. If erratic behavior occurs in a part, a difficult adjustment process occurs.

Sharp Holder

The Sharp holder also has three mechanisms as illustrated in Figure 2.25. One is a simple lead screw and the other two have a guideway and a guide boss. Plate A is fixed to the side frame. The LCD panel is attached to plate C. The following three DPs are defined:

- DP_1 : The lead screw for conjunction of plate B and screw 1
- DP_2 : The lead screw for conjunction of plate C, plate D, boss 1, boss 2 and screw 2
- DP_3 : The lead screw for conjunction of plate B, plate E, boss 2 and screw 3

If screw 1 is rotated, plate B moves in the X direction. Since the LCD panel is attached to plate C, it moves with plate B in the X direction. Thus, DP_1 only affects FR_1 . Rotating screw 2 moves plate D in the X direction and the wall of the guideway in plate D pushes boss 1. As a result, plate C moves along the Y axis because the vertical groove in plate B guides the movement of boss 1 in the Y direction. Therefore, rotating screw 2 moves the LCD panel in the Y direction and DP_2 only affects FR_2 .

Screw 3 moves plate E in the X direction and the guideway of plate E pushes boss 2. Since boss 1 does not have directional constraints, plate C rotates with

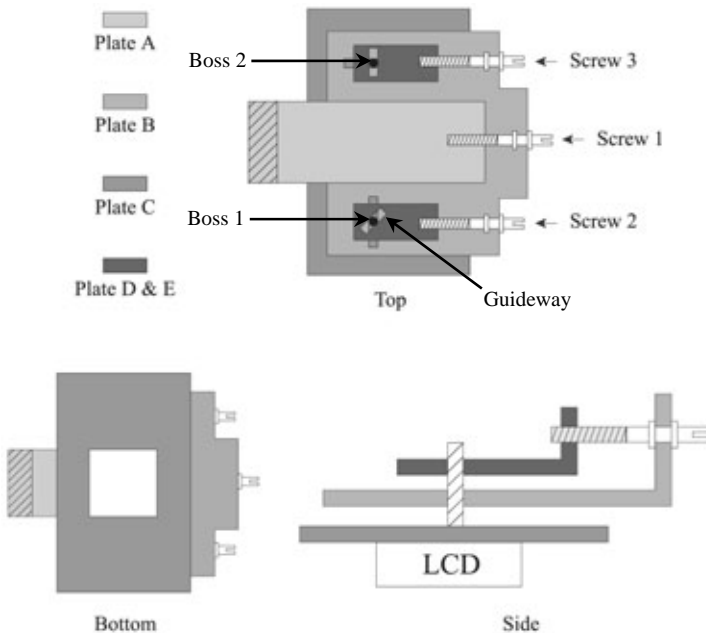

Figure 2.25. The Sharp LCD holder mechanism

respect to boss 2. Rotating screw 3 is projected into the X and Y directions. Therefore, DP_3 affects FR_1 and FR_3 . The design equation is in Equation 2.76.

$$\begin{bmatrix} T(X) \\ T(Y) \\ R(Z) \end{bmatrix} = \begin{bmatrix} A_{11} & 0 & A_{13} \\ 0 & A_{22} & 0 \\ 0 & 0 & A_{33} \end{bmatrix} \begin{bmatrix} DP_1 \\ DP_2 \\ DP_3 \end{bmatrix} \quad (2.76)$$

The design matrix is triangular, so it is a decoupled design. If the adjustment process proceeds as the design matrix indicates, the Independence Axiom is satisfied. After the LCD panel is aligned by DP_3 in the $R(Z)$ axis, DP_1 and DP_2 should be adjusted.

In the above method, existing designs can be analyzed or compared by using the Independence Axiom. In this case, it is easy because the Independence Axiom is violated by one design. However, when both designs satisfy the Independence Axiom, they can be compared by reangularity (R) and semangularity (S), or by the information content.

Example 2.15 [An Example of Design Improvement: Parking Mode of an Automatic Transmission] (NSF 1998, Suh 2000)

An automobile automatic transmission has a parking mode. The parking mode locks the transmission mechanism when the vehicle is unattended. Thus, it prevents the vehicle from moving on its own. When an automobile is parked on a hill, drivers complain that unlocking is difficult. Also, excessive vibration can occur during the unlocking process. The current design is illustrated in Figure 2.26. Analyze the current design and develop an improved design.

Solution

First, the current design should be analyzed. In Figure 2.26, the pawl is locked in the sprocket by the shift-linkage and the vehicle is in parking mode. The sprocket is attached to the automatic transmission. If the shift-linkage is changed to the parking mode, the detent spring activates the hydraulic system and spring A attached to the cam is pushed. The shift-linkage develops the spring force in spring A, the cam is pushed in as illustrated in Figure 2.26, the surface shape moves the pawl to the engagement position and the sprocket is locked by the pawl. The vehicle is then in the parking mode.

While the car is in motion, the pawl cannot be engaged with the sprocket. If the car speed is over 4.8km/hour, an impact load occurs between the pawl and the sprocket, and the impact load prevents engagement. When the impact load is greater than the spring force, the parking mode does not function.

When the car is parked on a hill, the automobile weight exerts a torque on the sprocket and the torque is transmitted to the cam by the tooth shape and the pawl. Therefore, to disengage the parking mode, we need more force than the friction force between the cam and the pawl. If the cam is pulled out, the pawl is released by the tension spring.

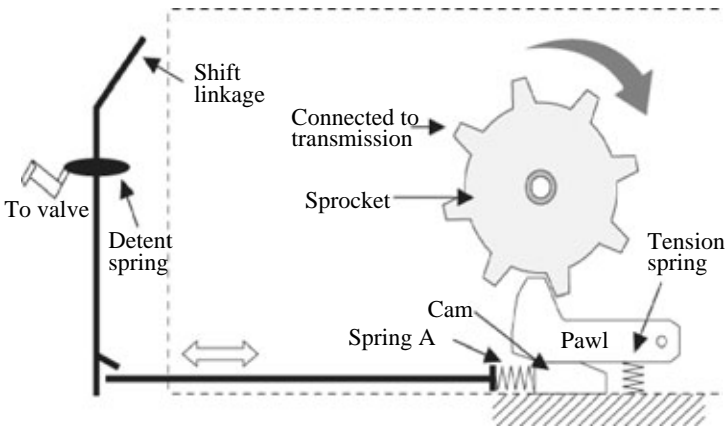

Figure 2.26. Schematic drawing of a parking mechanism

Figure 2.27 is the free body diagram of the forces acting on the pawl. F_R is the reaction force between the pawl and the sprocket. F_C is the reaction force between the pawl and the cam, F_S is the spring force, F_P is the force acting on the pawl by the pin and μ is the friction coefficient between the pawl and the cam. As the slope of the tooth profile in the pawl increases, F_R , F_C and μF_C increase in order. F_S is constant while the cam is engaged.

The functional requirements of the system are as follows:

- FR_1 : Engage the pawl in the locked position.
- FR_2 : Disengage the pawl from the locked position.
- FR_3 : Prevent accidental engagement.

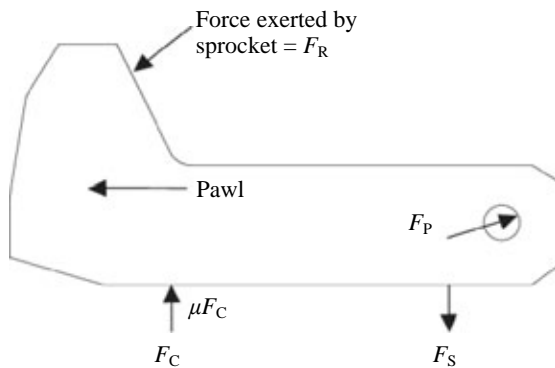

Figure 2.27. Free body diagram of the pawl

FR_4 : Keep the pawl in the engaged position.

FR_5 : Carry the load transmitted by the vehicle.

The current design has the following design parameters:

DP_1 : The tapered section of the cam profile

DP_2 : Tension spring

DP_3 : The tooth profile of the sprocket and the pawl/spring A/shift-linkage/
tension spring

DP_4 : The flat surface of the cam

DP_5 : The flat surface of the pawl/cam

The design equation is

$$\begin{bmatrix} FR_1 \\ FR_2 \\ FR_3 \\ FR_4 \\ FR_5 \end{bmatrix} = \begin{bmatrix} X & 0 & 0 & X & X \\ X & X & 0 & 0 & X \\ 0 & X & X & 0 & 0 \\ 0 & X & 0 & X & X \\ X & X & 0 & X & X \end{bmatrix} \begin{bmatrix} DP_1 \\ DP_2 \\ DP_3 \\ DP_4 \\ DP_5 \end{bmatrix} \quad (2.77)$$

Therefore, the current design is coupled. The reason is that the vehicle weight transmitted by the automatic transmission is sustained by the pawl and the cam. As the slope of the hill increases, the normal and friction forces on the cam increase and disengagement of the parking mode becomes more difficult.

Newly Proposed Design

A newly proposed design is presented in Figure 2.28. The sprocket of the new design has a different tooth profile. The tapered section near the outer edge of the tooth is to prevent accidental engagement of the pawl, and the flat surface of the tooth profile of the pawl transmits the vehicle weight. The tapered section of the pawl prevents accidental engagement when the vehicle speed is lower than 4.8 km/hour. The vertical position of the pin in the pawl is the same as the one for the flat surface of the tooth profile of the pawl. Therefore, F_R and F_P of Figure 2.28 are of the same height and the force between the pawl and the cam is eliminated. The pin is in charge of the vehicle weight and the weight is not transmitted to the cam. F_R is almost the same as F_P .

The FRs are the same as before and DPs are as follows:

DP_1 : The tapered section of the cam profile

DP_2 : Tension spring

DP_3 : Tooth profiles of the sprocket wheel and the tapered section of the
pawl/spring A/shift linkage system

DP_4 : The flat surface of the cam

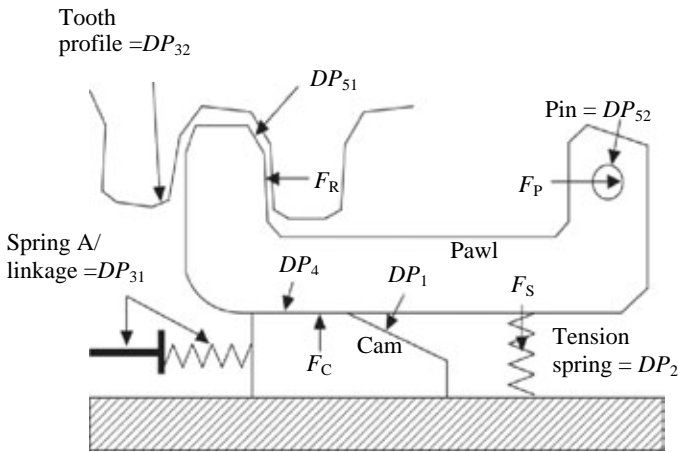

Figure 2.28. Newly proposed design

DP_5 : The flat surfaces of pawl/sprocket and pin

The design equation is as follows:

$$\begin{bmatrix} FR_4 \\ FR_2 \\ FR_3 \\ FR_1 \\ FR_5 \end{bmatrix} = \begin{bmatrix} X & 0 & 0 & 0 & 0 \\ X & X & 0 & 0 & 0 \\ 0 & X & X & 0 & 0 \\ X & 0 & 0 & X & 0 \\ 0 & 0 & 0 & 0 & X \end{bmatrix} \begin{bmatrix} DP_4 \\ DP_2 \\ DP_3 \\ DP_1 \\ DP_5 \end{bmatrix} \tag{2.78}$$

The design is a decoupled one.

From the characteristics of DP_3 , FR_3 is decomposed as follows:

FR_{31} : Control the force that pushes the pawl into sprockets.

FR_{32} : Generate the reaction force if the sprocket is turning.

The corresponding DPs are

DP_{31} : Spring A/linkage

DP_{32} : Tooth profile of the sprocket

The related design matrix is triangular.

FR_5 and DP_5 are decomposed as follows:

FR_{51} : Transmit the force from the sprocket to the pawl.

FR_{52} : Carry the load transmitted.

DP_{51} : Nearly vertical surface of the pawl and the sprocket tooth profile

DP_{52} : Pin located collinearly with the force vector acting on the vertical surface the pawl

To minimize the reaction force between the cam and the pawl, the reaction force between the sprocket and the pawl should be close to the horizontal line. For this, DP_{51} is nearly vertical. The small slope between the pawl and the sprocket is used to minimize the reaction of the pawl. The design equation is diagonal. An improved design is found by using the Independence Axiom. A better idea may be created with application of the Independence Axiom.

2.5 Software Design Using the Axiomatic Approach

2.5.1 Software Design

The importance of software is being recognized in all engineering fields. Software is a technology or a methodology to manipulate computers. Software engineering is a method or a tool to develop reliable software with minimum cost. Generally, engineering software developers lack understanding in software engineering. Engineers tend to develop software based on their own methods and experiences, which is neither systematic nor efficient. Moreover, documentation is not sufficient during software development. Therefore, further development is needed for maintenance, modification, extension, *etc.*

In software engineering, these problems are solved by two approaches. First, many resources are invested in the early stages. Independent modules are defined and software is designed based on the modules. Thus later work can be considerably reduced. Second, new systematic languages such as the object oriented language can be utilized. Thus the work of the developers can be reduced. However, although developers use such methods, they still have classical problems such as debugging, maintenance, modification and extension. The most important reason is that physically independent modules can be functionally coupled during the execution of software.

As mentioned earlier, the axiomatic approach is a method to maintain the independence between functional requirements. It can be applied to software engineering. In this section, the axiomatic approach is applied to software development to overcome the intrinsic limits of conventional software engineering.

2.5.2 Conventional Languages and Axiomatic Design

In software engineering, partitioning is frequently used to manage complexity. That is, a large program is divided into manageable smaller modules. However, if a small module is not independent or the interactions are not clearly defined,

complexity cannot be controlled. Modulation enables easy maintenance and modification.

From the axiomatic viewpoint, CAs, FRs, DPs and PVs are redefined for software development as follows:

- CAs: Customer requirements or attributes that the software should satisfy
 FRs: Functional requirements that software should satisfy in engineering terminology
 DPs: (1) Input data when an algorithm is developed
 (2) Signal from the hardware where software is loaded
 (3) Program code
 PVs: Subroutine, machine language, compiler

The process for software development will be explained based on the above definitions. The development of a software system for libraries is selected as an example (Kim *et al.* 1991, Suh 2000).

Step 1. Definition of FRs for the software system

The functional requirements of the highest level are defined based on the customer needs. A functional requirement is a function that the software system intends to carry out. As mentioned earlier, it starts with a verb because it executes a process with input.

The functional requirements are as follows:

- FR_1 : Generate the call number and keyword database for new incoming books.
 FR_2 : Provide a list of books that corresponds to subject keywords of a search query.

Step 2. Mapping between the domains to maintain the independence of FRs

Design parameters are defined in the physical domain. Design parameters determine how to achieve the functional requirements. In software design, design parameters correspond to input data and result data from program execution.

The design parameters of the highest level are as follows:

- DP_1 : A classification system based on the content of the book
 DP_2 : A search system based on the set of subject keywords

The FRs and DPs satisfy the Independence Axiom as a decoupled design because the design matrix is triangular as in Equation 2.79.

$$\begin{bmatrix} FR_1 \\ FR_2 \end{bmatrix} = \begin{bmatrix} A_{11} & 0 \\ A_{21} & A_{22} \end{bmatrix} \begin{bmatrix} DP_1 \\ DP_2 \end{bmatrix} \quad (2.79)$$

An element of the design matrix A_{ij} can be an operation or a calling function. In this case, the functional requirements can be satisfied by the modules in Equation 2.80,

$$\begin{aligned} FR_1 &= M_1 DP_1 \\ FR_2 &= M_2 DP_2 \end{aligned} \tag{2.80}$$

where M_1 and M_2 are modules defined as follows:

$$\begin{aligned} M_1 &= A_{11} \\ M_2 &= A_{21} \frac{DP_1}{DP_2} + A_{22} \end{aligned} \tag{2.81}$$

A module is regarded as an algorithm. It can be a logical operation or a function representing an independent system.

Step 3. Decomposition of FRs and DPs

It was mentioned earlier that the FRs and DPs are decomposed up to the lowest level. The DPs of the current level are references for the FRs of the next level. Therefore, the functional requirements of the lower level FR_{ij} are defined based on DP_i of the upper level. The decomposition is carried out by a zigzagging process.

FR_1 of Step 1 is decomposed into FR_{11} and FR_{12} as follows:

FR_{11} : Assign a call number to a new book.

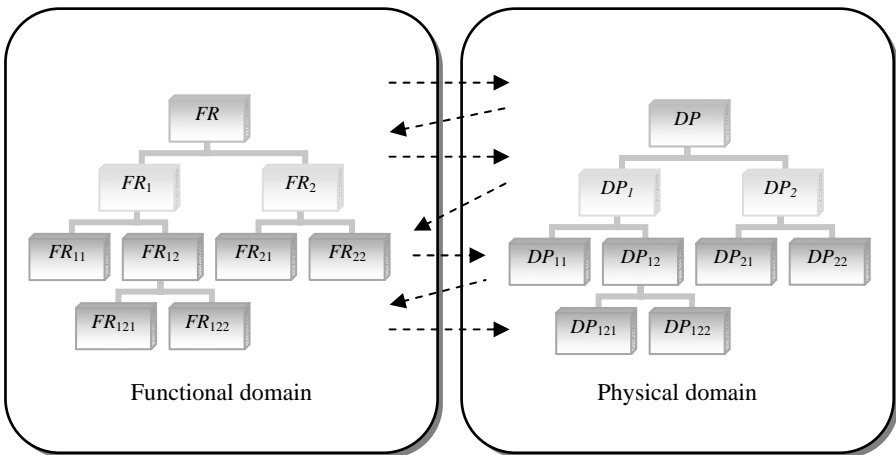

Figure 2.29. Hierarchical structure of a software system for libraries

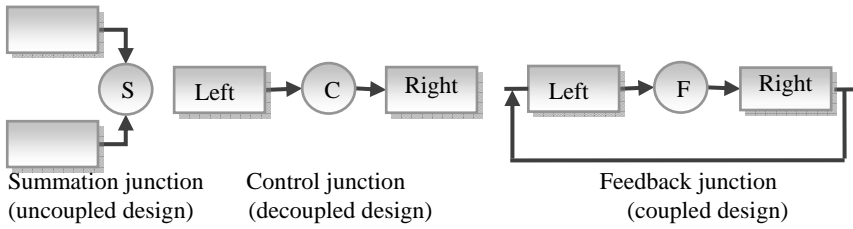

Figure 2.30. Unit junctions

FR_{12} : Generate subject keywords for the new book.

DP_{11} : Information on the title page of the book

DP_{12} : The table of contents of the book

FR_2 can also be decomposed and decomposition is continued to the lowest level. The result of the decomposition is illustrated in Figure 2.29.

Step 4. Definition of modules

After decomposition, the modules are defined for all FRs and DPs. Each module can be independently coded. The entire flow can be schematically drawn by junctions and modules. Figure 2.30 presents unit junctions. There are three junctions as follows:

Summation junction (⊕): This is for an uncoupled design. An FR of the upper level is satisfied by summation of results from the modules of the lower level.

Control junction (⊙): In Figure 2.30, the results of the left hand side

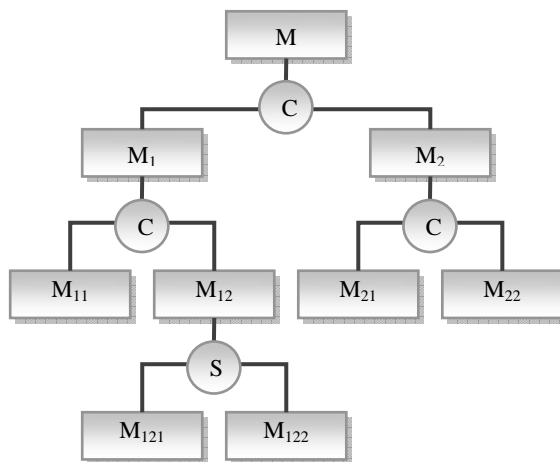

Figure 2.31. Module junction structure diagram of Figure 2.29

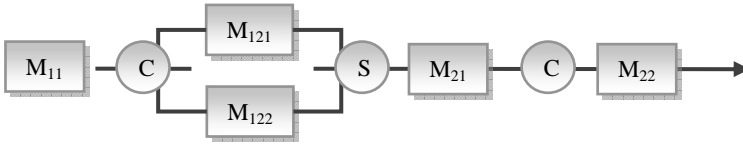

Figure 2.32. System flow of Figure 2.29

modules are utilized to control the module of the right hand side. This represents a decoupled design.

Feedback junction (\oplus): This is for a coupled design. In Figure 2.30, the results of the right hand side return to the left hand side as feedback. Thus, many repetitions are needed. When there are many feedback junctions, the program is not manageable.

With the junctions, the hierarchical structure of FRs and DPs can be represented by a tree structure. This is called a module junction structure diagram. The example in Figure 2.29 is modified to that in Figure 2.31. The module junction structure diagram can be modified to the flow of the network type. Figure 2.32 shows the flow induced from Figure 2.31.

In this section, the application of axiomatic design is explained for the development of software using conventional languages.

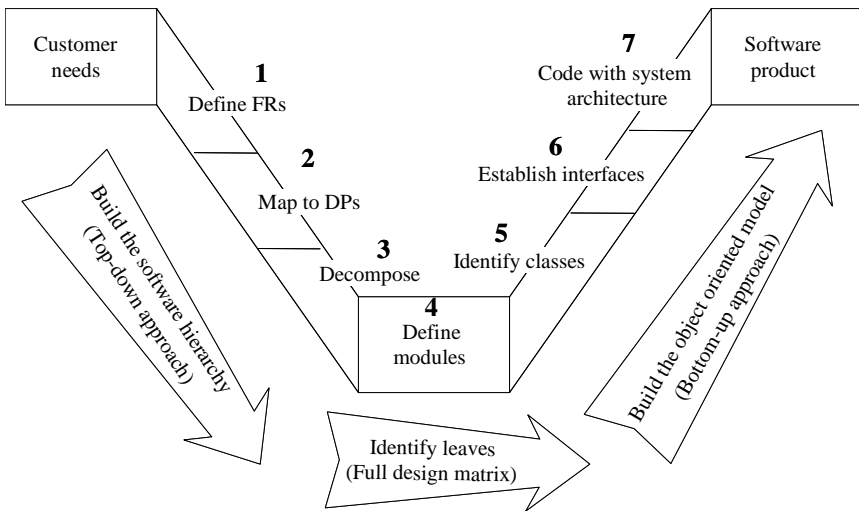

Figure 2.33. The axiomatic approach for objected oriented programming (V-model)

2.5.3 Object Oriented Programming and Axiomatic Design

Since the 1980s, the object oriented paradigm has received much attention in software engineering. It is a new approach compared to process oriented languages such as C, Pascal, Fortran, *etc.* The object oriented language, which is popular these days, is appropriate for graphic user interface (GUI). The object oriented technology provides methods to use existing programs. Common libraries are prepared and specialized by customization. Also, a large program is divided into independent objects and objects have relations by well defined interfaces.

Due to the above advantages, object oriented programming (OOP) is frequently utilized in software development. The V-model has been proposed to exploit the axiomatic approach in object oriented programming (Do 2000). In the V-model, a designer defines the functional requirements of the software and establishes independent modules from zigzagging decomposition. Each module is modified to a class of the object oriented programming and coded. The process consists of two steps: construction of the full design matrix with the top-down approach and

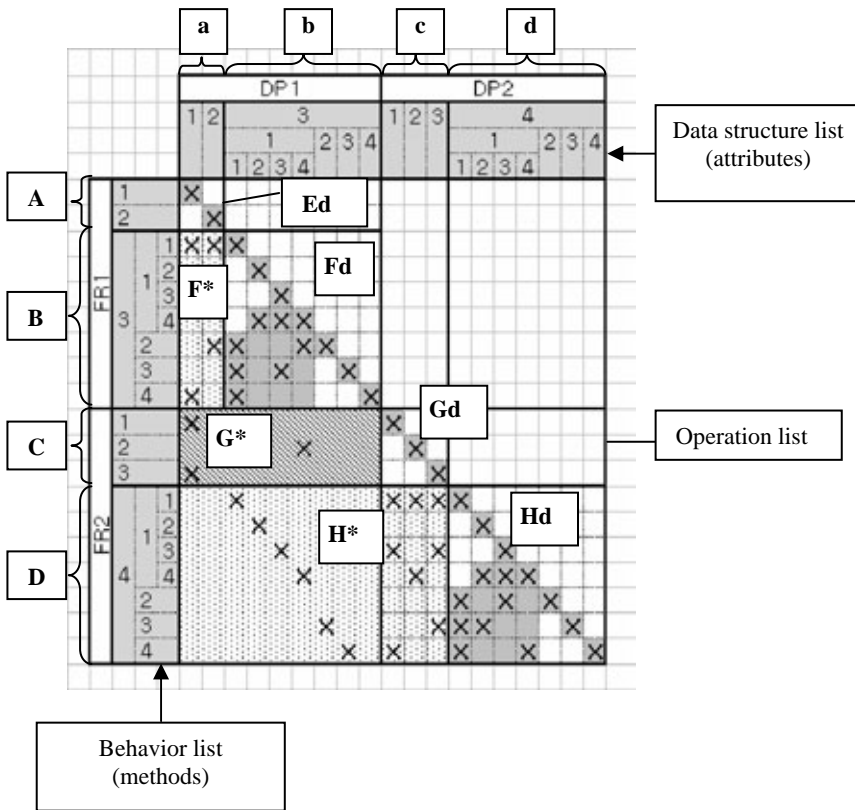

Figure 2.34. The full design matrix using object oriented programming

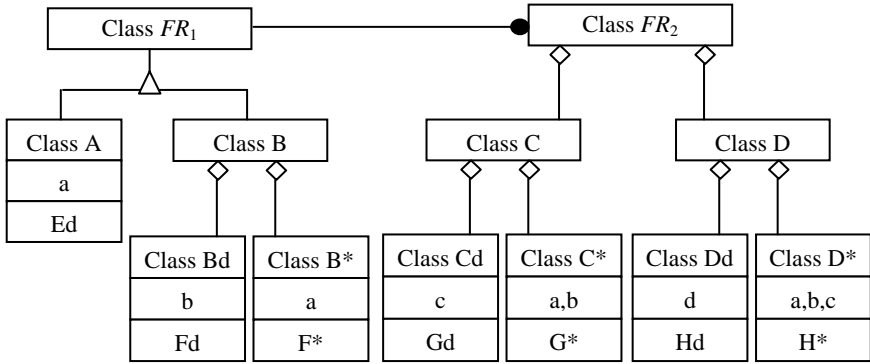

Figure 2.35. The class diagram for the full design matrix in Figure 2.34

coding the program with the bottom-up approach. The process is illustrated in Figure 2.33. The top-down approach up to Step 4 is the same as the steps explained in the previous section. Thus, this section describes the steps after Step 4.

Step 5. Identification of objects, attributes and operations

The full design matrix is constructed after the decomposition process. It shows all FRs and DPs. An example of the full design matrix is presented in Figure 2.34. Rows of Figure 2.34 are FRs and the columns are DPs. "X" means an algorithm of a logical relation between an FR and a DP. The logical relation includes not only operators such as "+" and "*" but also control statements such as "if," "for," etc. In Figure 2.34, a rectangle with thick lines is an object. The object is composed of attributes in columns (DPs) and the methods of the operations list within the rectangle. The method of the object is the module. Therefore, an object executes a method with attributes and satisfies the functional requirement.

Step 6. Establishment of interfaces between objects

An object is expressed by a class and a class is a template that defines the format of the object. Classes share attributes that are the data structures and behaviors. In this step, the relationships between classes are set up. They are generalization, aggregation and association. Figure 2.35 presents a class diagram according to the design matrix of Figure 2.34. We can see the data and their functions in Figure 2.35 and the class diagram shows the relations of classes. The design process is shown by the aforementioned flow. Thus, software development easily proceeds with these.

Step 7. Coding with system architecture

Coding is the programming process based on the classes and their relationships. The flow chart of the design matrix helps with the coding.

2.6 Discussion

As explained earlier, the two axioms are independent of each other. Thus, we have to apply them separately. Generally, the Independence Axiom should be satisfied first. In many cases, the design is terminated only with the application of the Independence Axiom. When both of the axioms are utilized, the flow in Figure 2.20 is recommended.

When we apply the Independence Axiom, the ideal design should be kept in mind. The numbers of FRs and DPs are the same in an ideal design. The design matrix should be a square diagonal or triangular one. If the numbers are different, the design is coupled. When the number of DPs is smaller, new DPs should be added. In a redundant design where the number of DPs is larger, the number should be reduced or some specific DPs should be fixed.

Suppose we have the following redundant design:

$$\begin{bmatrix} FR_1 \\ FR_2 \end{bmatrix} = \begin{bmatrix} X & X & 0 \\ 0 & X & X \end{bmatrix} \begin{bmatrix} DP_1 \\ DP_2 \\ DP_3 \end{bmatrix} \quad (2.82)$$

First, we can fix DP_2 . Then the design becomes an uncoupled one. That is, redundant parameters are fixed to make the design uncoupled or decoupled with the rest of the parameters.

The Information Axiom is utilized to quantitatively evaluate a design that satisfies the Independence Axiom. It is especially useful when multiple designs are compared. When multiple designs, which satisfy the Independence Axiom, are found, the one with the minimum information content is selected as the final design.

Basically, the axiomatic design can be exploited in creating a new design or evaluating existing designs. It is quite useful in the conceptual design of new products. Although the history of the method is relatively short, the usefulness has been verified through many examples. There are some common responses from application designers. First, they tend to easily agree with the axioms and think that they can use them right away. However, they have difficulties in testing the axioms with their existing products. In most cases, they tend to look at the designs with previous concepts, not from an axiomatic viewpoint. Many designers tend to stop applying axiomatic design at this stage. However, if the designers overcome this stage, they realize the usefulness of axiomatic design. It is important not to consider the existing products when the functional requirements are defined. Instead, designers should think about the functional requirements in a solution neutral environment. In recent research, axiomatic design is utilized in detailed designs. Later examples will demonstrate how axiomatic design is applied to the detailed design process of structures.

2.7 Exercises

- 2.1 Analyze the design of a CD player with the Independence Axiom.
- 2.2 Analyze the design of a cellular phone with the Independence Axiom.
- 2.3 Find a product that uses the idea of physical integration and analyze it with the Independence Axiom.
- 2.4 To design an automobile fuel tank, the following functional requirements are defined.

FR_1 : Provide in-flow of gasoline into the tank.

FR_2 : Provide a means of stopping the pump when the tank is full.

FR_3 : Prevent gasoline from surging back out through the inlet tube as a result of the vapor pressure of the gasoline when the gasoline level is higher than the end of the pipe.

FR_4 : Control vapor pressure of the gasoline.

Design a fuel tank that satisfies above four FRs. The new tank should cost less than the current one.

- 2.5 We have a design with the following FR–DP relation:

$$\begin{bmatrix} f_1 \\ f_2 \\ f_3 \end{bmatrix} = \begin{bmatrix} X & 0 & 0 \\ X & X & 0 \\ X & X & X \end{bmatrix} \begin{bmatrix} x_1 \\ x_2 \\ x_3 \end{bmatrix}$$

The detailed relationships are

$$f_1 = x_1^2$$

$$f_2 = x_1^2 + x_1x_2 + x_2^2$$

$$f_3 = x_1^2 + x_2^2 + x_2x_3 + x_3^2$$

- (1) At $\mathbf{x} = (1.0, 1.0, 1.0)$, obtain the approximated design matrix.
 - (2) Obtain a condition so that the design is uncoupled in a specific design window.
- 2.6 Calculate the reangularity and semangularity of the design matrices and discuss the characteristics.

$$\begin{array}{lll}
 \text{(a)} \begin{bmatrix} 3 & 1 \\ 1 & 2 \end{bmatrix} & \text{(b)} \begin{bmatrix} 8 & 0.2 \\ 0.3 & 4 \end{bmatrix} & \text{(c)} \begin{bmatrix} 9.5 & 2.4 \\ 3.2 & 4.8 \end{bmatrix} \\
 \text{(d)} \begin{bmatrix} 5 & 0 \\ 1 & 2 \end{bmatrix} & \text{(e)} \begin{bmatrix} 5 & 0 \\ 4 & 2 \end{bmatrix} & \text{(f)} \begin{bmatrix} 3 & 0 \\ 0 & 2 \end{bmatrix}
 \end{array}$$

2.7 We have two designs as follows:

$$\text{Design 1} \begin{bmatrix} FR_1 \\ FR_2 \end{bmatrix} = \begin{bmatrix} 3 & 1 \\ 2 & 4 \end{bmatrix} \begin{bmatrix} DP_1 \\ DP_2 \end{bmatrix}$$

$$\text{Design 2} \begin{bmatrix} FR_1 \\ FR_2 \end{bmatrix} = \begin{bmatrix} 3 & 0 \\ 8 & 5 \end{bmatrix} \begin{bmatrix} DP_1 \\ DP_2 \end{bmatrix}$$

- (1) Draw an FR–DP graph for each design and explain the order of the design process.
- (2) Calculate the reangularity and semangularity of each design and compare the results.

2.8 Suppose we have the following FR–DP relation:

$$\begin{bmatrix} FR_1 \\ FR_2 \\ FR_3 \end{bmatrix} = \begin{bmatrix} 5 & 0.1 & 0.2 \\ 0.3 & 7 & 0.4 \\ 0.5 & 0.7 & 4 \end{bmatrix} \begin{bmatrix} DP_1 \\ DP_2 \\ DP_3 \end{bmatrix}$$

When $DP_1 = DP_2 = DP_3 = 1$, the manufacturing tolerances are ΔDP_1 , ΔDP_2 and ΔDP_3 .

- (1) In Equation 2.21, $(\Delta FR_i)_{\text{allowable}}$ is 0.5. Write inequality equations composed of ΔDP_1 , ΔDP_2 and ΔDP_3 for the condition that the above design is an uncoupled one.
- (2) Designer specified tolerances are $4.8 < FR_1 < 5.8$, $7.3 < FR_2 < 8.0$ and $5.1 < FR_3 < 6.3$. Similarly as in (1), write the condition for the above design to be an uncoupled one.

2.9 We have the following designs:

$$\text{Design 1} \begin{bmatrix} FR_1 \\ FR_2 \end{bmatrix} = \begin{bmatrix} 3 & 0 \\ 0 & 4 \end{bmatrix} \begin{bmatrix} DP_1 \\ DP_2 \end{bmatrix}$$

$$\text{Design 2} \begin{bmatrix} FR_1 \\ FR_2 \end{bmatrix} = \begin{bmatrix} 3 & 0 \\ 2 & 4 \end{bmatrix} \begin{bmatrix} DP_1 \\ DP_2 \end{bmatrix}$$

$$\text{Design 3} \begin{bmatrix} FR_1 \\ FR_2 \end{bmatrix} = \begin{bmatrix} 3 & 1 \\ 2 & 4 \end{bmatrix} \begin{bmatrix} DP_1 \\ DP_2 \end{bmatrix}$$

- (1) Which one satisfies the Independence Axiom?
- (2) Among the ones that satisfy the Independence Axiom, select the best one in the context of independence by comparing R and S .
- (3) For the designs satisfying the Independence Axiom, $\Delta DP_i = 0.1$ and $\Delta FR_i = 0.5$, $i = 1, 2$. Calculate the information content at the design point that satisfies the functional requirements.
 - (a) When DPs have uniform distribution in the DP range, calculate the information content by the graphical method and compare them.
 - (b) Calculate the information content in the same manner as (a) in the FR range.
 - (c) Distributions of the design parameters are as follows:

$$\text{Distribution of } DP_1 \quad p_{\delta DP_1} = -\frac{3}{4(\Delta DP_1)^3} (\delta DP_1)^2 + \frac{3}{4(\Delta DP_1)}$$

$$\text{Distribution of } DP_2 \quad p_{\delta DP_2} = \frac{1}{(\Delta DP_2)^2} \delta DP_2 + \frac{1}{\Delta DP_2} \quad \text{when}$$

$$\delta DP_2 < 0, \text{ and } p_{\delta DP_2} = \frac{-1}{(\Delta DP_2)^2} \delta DP_2 + \frac{1}{\Delta DP_2} \quad \text{when } \delta DP_2 \geq 0$$

Calculate the information content by the integration method and compare the information contents.

- 2.10 We have a decoupled design and one element of the design matrix is expressed by an unknown x . The value of x is 0.5, 1 or 2 in the following design equation:

$$\begin{bmatrix} 0 < FR_1 < 2 \\ 0 < FR_2 < 2 \end{bmatrix} = \begin{bmatrix} 1 & 0 \\ 1 & x \end{bmatrix} \begin{bmatrix} 0 < DP_1 < 1 \\ 0 < DP_2 < 1 \end{bmatrix}$$

For each x , calculate the following:

- (1) The probability of success.
 - (2) Tolerances to have 100% of the probability of success. Any method can be used for the evaluation of the probability of success. Discuss the trend according to x .
- 2.11 Make up a problem for buying a laptop computer in the same way as in the house buying problem and solve it.

2.12 We have the following designs:

$$\text{Design 1 } \begin{bmatrix} FR_1 \\ FR_2 \end{bmatrix} = \begin{bmatrix} 100 & 0 \\ 0 & 100 \end{bmatrix} \begin{bmatrix} DP_1 \\ DP_2 \end{bmatrix}$$

$$\text{Design 2 } \begin{bmatrix} FR_1 \\ FR_2 \end{bmatrix} = \begin{bmatrix} 1 & 0 \\ 1 & 1 \end{bmatrix} \begin{bmatrix} DP_1 \\ DP_2 \end{bmatrix}$$

The targets of FRs are 10 and 20, respectively. The allowable tolerances are $-9.5 < FR_1 < 10.5$ and $-19.5 < FR_2 < 20.5$, and the tolerance of each DP is ± 2.0 .

- (1) Calculate R and S . Which one is better from the viewpoint of independence?
- (2) When functional requirements are satisfied, calculate the information content by the graphical method and select the better one.
- (3) Discuss the results.

2.13 If the off-diagonal terms are small in a decoupled design, it can be considered as an uncoupled design. Explain this with Equation 2.21 and R .

2.14 Expand the graphical method for a decoupled design to a coupled design.

2.A Corollaries and Theorems

Corollary 2.A.1 [Decoupling of Coupled Designs]

Decouple or separate parts or aspects of a solution if FRs are coupled or become independent in the designs proposed.

Corollary 2.A.2 [Minimization of FRs]

Minimize the number of FRs and constraints.

Corollary 2.A.3 [Integration of Physical Parts]

Integrate design features in a single physical part if FRs can be independently satisfied in the proposed solution.

Corollary 2.A.4 [Use of Standardization]

Use standardized or interchangeable parts if the use of these parts is consistent with FRs and constraints.

Corollary 2.A.5 [Use of Symmetry]

Use symmetrical shapes and/or components if they are consistent with FRs and constraints.

Corollary 2.A.6 [Largest Design Ranges]

Specify the largest allowable design range in stating FRs.

Corollary 2.A.7 [Uncoupled Design with Less Information]

Seek an uncoupled design that requires less information than coupled designs in satisfying a set of FRs.

Corollary 2.A.8 [Effective Reangularity of a Scalar]

The effective reangularity R for a scalar coupling “matrix” or element is unity.

Theorem 2.A.1 [Coupling Due to an Insufficient Number of DPs]

When the number of DPs is less than the number of FRs, either a coupled design results or the FRs cannot be satisfied.

Theorem 2.A.2 [Decoupling of a Coupled Design]

When a design is coupled because of a larger number of FRs than DPs (*i.e.*, $m > n$), it may be decoupled by the addition of new DPs so as to make the number of FRs and DPs equal to each other if a subset of the design matrix containing $n \times n$ elements constitutes a triangular matrix.

Theorem 2.A.3 [Redundant Design]

When there are more DPs than FRs, the design is either a redundant design or a coupled design.

Theorem 2.A.4 [Ideal Design]

In an ideal design, the number of DPs is equal to the number of FRs and the FRs are always maintained independently of each other.

Theorem 2.A.5 [Need for a New Design]

When a given set of FRs is changed by the addition of a new FR, by substitution of one of the FRs with a new one, or by selection of a completely different set of FRs, the design solution given by the original DPs cannot satisfy the new set of FRs. Consequently, a new design solution must be sought.

Theorem 2.A.6 [Path Independence of an Uncoupled Design]

The information content of an uncoupled design is independent of the sequence by which the DPs are changed to satisfy the given set of FRs.

Theorem 2.A.7 [Path Dependency of Coupled and Decoupled Design]

The information contents of coupled and decoupled designs depend on the sequence by which the DPs are changed to satisfy the given set of FRs.

Theorem 2.A.8 [Independence and Design Range]

A design is an uncoupled design when the designer-specified range is greater than

$$\sum_{\substack{j=1 \\ j \neq i}}^n \left(\frac{\partial FR_i}{\partial DP_j} \right) \Delta DP_j$$

in which case the off-diagonal elements of the design matrix can be neglected from the design consideration.

Theorem 2.A.9 [Design for Manufacturability]

For a product to be manufacturable with reliability and robustness, the design matrix for the product **A** (which relates the **FR** vector for the product to the **DP** vector of the product), times the design matrix for the manufacturing process **B** (which relates the **DP** vector to the **PV** vector of the manufacturing process), must yield either a diagonal or a triangular matrix. Consequently, when either **A** or **B** represents a coupled design, the independence of FRs and robust design cannot be achieved. When they are full triangular matrices, either both of them must be upper triangular or both must be lower triangular for the manufacturing process to satisfy independence of functional requirements.

Theorem 2.A.10 [Modularity of Independence Measures]

Suppose that a design matrix **A** can be partitioned into square submatrices that are nonzero only along the main diagonal. Then the reangularity and semangularity for **A** are equal to the product of their corresponding measures for each of the nonzero submatrices.

Theorem 2.A.11 [Invariance]

Reangularity and semangularity for a design matrix **A** are invariant under alternative orderings of the FR and DP variables, as long as the orderings preserve the association of each FR with its corresponding DP.

Theorem 2.A.12 [Sum of Information]

The sum of information for a set of events is also information, provided that proper conditional probabilities are used when the events are not statistically independent.

Theorem 2.A.13 [Information Content of the Total System]

If each DP is probabilistically independent of other DPs, the information content of the total system is the sum of the information of all individual events associated with the set of FRs that must be satisfied.

Theorem 2.A.14 [Information Content of Coupled Versus Uncoupled Designs]

When the state of FRs is changed from one state to another in the functional domain, the information required for the change is greater for a coupled design than for an uncoupled design.

Theorem 2.A.15 [Design—Manufacturing Interface]

When the manufacturing system compromises the independence of the FRs of the product, either the design of the product must be modified or a new manufacturing process must be designed and/or used to maintain the independence of the FRs of the products.

Theorem 2.A.16 [Equality of Information Content]

All information contents that are relevant to the design task are equally important regardless of their physical origin, and no weighting factor should be applied to them.

Theorem 2.A.17 [Design in the Absence of Complete Information]

Design can proceed even in the absence of complete information only in the case of a decoupled design if the missing information is related to the off-diagonal elements.

Theorem 2.A.18 [Existence of an Uncoupled or Decoupled Design]

There always exists an uncoupled or decoupled design that has less information than a coupled design.

Theorem 2.A.19 [Robustness of Design]

An uncoupled design and a decoupled design are more robust than a coupled design in the sense that it is easier to reduce the information content of designs that satisfy the Independence Axiom.

Theorem 2.A.20 [Design Range and Coupling]

If the design ranges of uncoupled or decoupled designs are tightened, they may become coupled designs. Conversely, if the design ranges of some coupled designs are relaxed, the designs may become either uncoupled or decoupled.

Theorem 2.A.21 [Robust Design when the System Has a Nonuniform pdf]

If the probability distribution function (pdf) of the FR in the design range is nonuniform, the probability of success is equal to one when the system range is inside the design range.

Theorem 2.A.22 [Comparative Robustness of a Decoupled Design]

Given the maximum design ranges for a given set of FRs, decoupled designs cannot be as robust as uncoupled designs in that the allowable tolerances for DPs of a decoupled design are less than those of an uncoupled design.

Theorem 2.A.23 [Decreasing Robustness of a Decoupled Design]

The allowable tolerance and thus the robustness of a decoupled design with a full triangular matrix diminish with an increase in the number of functional requirements.

Theorem 2.A.24 [Optimum Scheduling]

Before a schedule for robot motion or factory scheduling can be optimized, the design of the tasks must be made to satisfy the Independence Axiom by adding decouplers to eliminate coupling. The decouplers may be in the form of a queue or of separate hardware or buffer.

Theorem 2.A.25 [“Push” System vs. “Pull” System]

When identical parts are processed through a system, a “push” system can be designed with the use of decouplers to maximize productivity, whereas when irregular parts requiring different operations are processed, a “pull” system is the most effective.

Theorem 2.A.26 [Conversion of a System with Infinite Time-Dependent Combinatorial Complexity to a System with Periodic Complexity]

Uncertainty associated with a design (or a system) can be reduced significantly by changing the design from one of serial combinatorial complexity to one of periodic complexity.

2.B Axiomatic Design of a Beam Adjuster for a Laser Marker

2.B.1 Problem Description

A laser marker is a machine that engraves characters or logos on the surface of semiconductors. Figure 2.B.1 shows a laser marker and Figure 2.B.2 is a schematic presentation of the inside. This is the beam scanning type YAG laser. It engraves the characters with a laser and high speed mirrors as we write with a pen. The YAG laser is a solid-state laser that uses crystals of yttrium, aluminum and garnet. As illustrated in Figure 2.B.1, the laser marker consists of a beam generating part and a scanning head.

In the beam generator, the laser beam is produced and reflected by the mirrors as illustrated in Figure 2.B.2. One laser beam is divided into two beams by an optical device. The optical device is a mirror that reflects 50% of the beam and passes the rest (see Figure 2.B.2). It is efficient in that two semiconductors are marked with one generator. This type is called a dual laser marker and is widely used in the field of semiconductor surface marking. In the scanning head, there are other mirrors controlled by high-speed motors. The fixed beam from the beam generator can be redirected by these mirrors to mark certain logos. If the beam direction is determined by the beam generator, the mirrors and motors in the scanning head make the detailed marks, and the motors are controlled by a computer program.

Before the real marking process is conducted, many test processes are needed for trial and error. If we use the YAG laser in this process, the surfaces of the

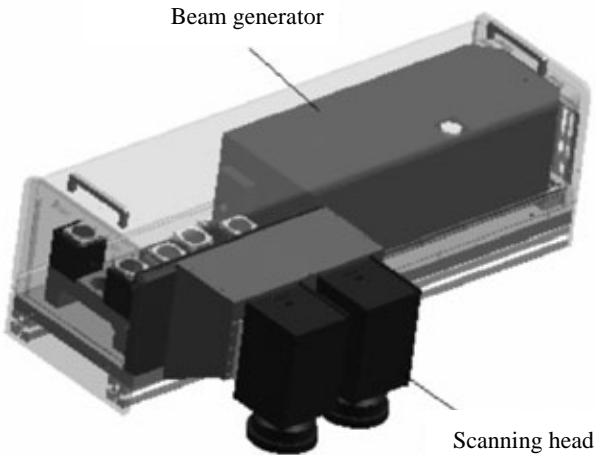

Figure 2.B.1. A beam scanning type laser marker

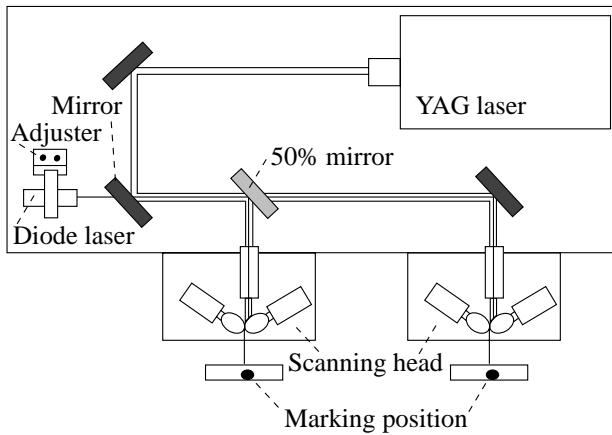

Figure 2.B.2. Schematic view of the inside of a laser marker

semiconductors are damaged. Therefore, a low-cost simulation is carried out by a diode laser as illustrated in Figure 2.B.2. The diode laser sheds a weak light beam and the simulation can be easily carried out.

The simulation process is as follows:

- (1) Test plates are placed at the marking positions in Figure 2.B.2. The YAG laser is turned on. The mirrors in the beam generator are positioned so as to make the beam go through the scanning head and mark points on the

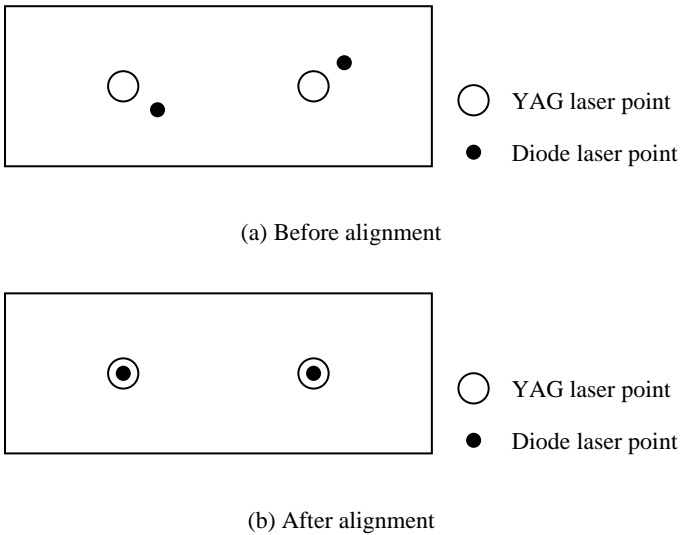

Figure 2.B.3. The process of beam alignment

- plates. The points are starting points of the marking process and illustrated as hollow points as shown in Figure 2.B.3.
- (2) The YAG laser is turned off. The diode laser is turned on. The solid points in Figure 2.B.3a are the final destinations of the diode laser.
 - (3) The adjuster of the diode laser is utilized to make two identical points as illustrated in Figure 2.B.3b. If the two points match, the angles and the final destinations from the YAG and diode lasers are considered identical. Now, we are sure that the two lasers have the same routes.
 - (4) The marking is simulated with the diode laser. That is, the motors in the scanning head are simulated by a computer program. The program is the one specifically developed for the marking process. As mentioned earlier, the marking result is visible.
 - (5) If the results are validated, the test is terminated.

Many problems occur in the adjuster of the diode laser. Currently, screws are used for the adjustment. Precise adjustment is difficult to obtain, since tolerances and human errors are involved. Thus, the adjustment is a long process.

2.B.2 Axiomatic Analysis of an Existing Design

Since the laser marking machine has already been commercialized, there is an existing design for the diode beam adjuster. Therefore, it is necessary to define the functional requirements and corresponding design parameters to evaluate the existing device. The relationship between FRs and DPs can be expressed by a design matrix. The FRs of the existing device is defined as follows:

FR_1 : Align the vertical position of the diode laser beam.

FR_2 : Align the vertical angle of the diode laser beam.

FR_3 : Align the horizontal position of the diode laser beam.

FR_4 : Align the horizontal angle of the diode laser beam.

FR_5 : Fix the beam alignment.

Figure 2.B.4 illustrates each functional requirement. The two beams from the YAG and diode lasers should be properly matched. First, the horizontal and vertical destinations of the diode laser should be the same as those of the YAG laser (FR_1, FR_3). Second, the angles of the beams must be the same (FR_2, FR_4).

Figure 2.B.5 illustrates the existing product. DPs corresponding to FRs are

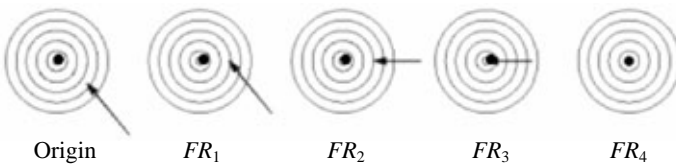

Figure 2.B.4. The functional requirements in order

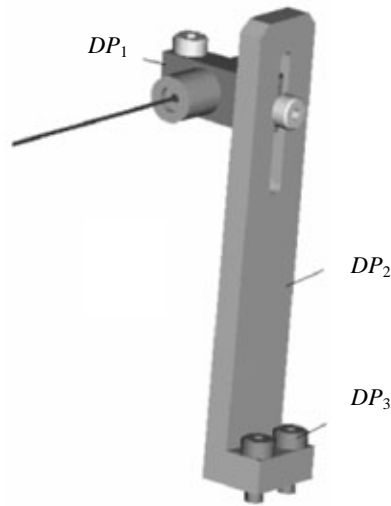

Figure 2.B.5. The existing design

defined as follows:

DP_1 : Vertically moving component

DP_2 : Supporting block

DP_3 : Fixing screw

The design matrix is a coupled one as follows:

$$\begin{bmatrix} FR_1 \\ FR_2 \\ FR_3 \\ FR_4 \\ FR_5 \end{bmatrix} = \begin{bmatrix} X & 0 & 0 \\ X & 0 & 0 \\ 0 & X & 0 \\ 0 & X & 0 \\ 0 & 0 & X \end{bmatrix} \begin{bmatrix} DP_1 \\ DP_2 \\ DP_3 \end{bmatrix} \tag{2.B.1}$$

The design in Equation 2.B.1 is a coupled design because the number of DPs is less than the number of FRs. When we move the solid points in Figure 2.B.3a (DP_1), the vertical angle also varies because FR_1 and FR_2 are coupled by DP_1 . In a similar manner, when we move the horizontal position (DP_2) the aligned angle can vary. If a design is coupled in the way of Equation 2.B.1, it can be decoupled by adding new DPs to make the numbers of FRs and DPs equal.

2.B.3 The Development of a New Beam Adjuster

New Design Using the Independence Axiom

A new design is created with new design parameters to satisfy the Independence Axiom. If we make a new design considering FR_1 and FR_2 , which are for the vertical position and angle, it can be expanded to FR_3 and FR_4 , which are for the horizontal position and angle. The design matrix for FR_1 and FR_2 is stated in Equation 2.B.2,

$$\begin{bmatrix} FR_1 \\ FR_2 \end{bmatrix} = \begin{bmatrix} X \\ X \end{bmatrix} [DP_1] \tag{2.B.2}$$

We can think of a design that has independent design parameters for the vertical position and angle. As a result, two designs are made. The first one is illustrated in Figure 2.B.6. The fastener at the back (DP_1) controls the vertical position and the front one (DP_2) controls the vertical angle. After the position is fixed, the fastener is tightened by a screw. The design matrix for Figure 2.B.6 is decoupled as follows:

$$\begin{bmatrix} FR_1 \\ FR_2 \end{bmatrix} = \begin{bmatrix} X & 0 \\ X & X \end{bmatrix} \begin{bmatrix} DP_1 \\ DP_2 \end{bmatrix} \tag{2.B.3}$$

We can have multiple designs satisfying the Independence Axiom. Another design is created as illustrated in Figure 2.B.7. Two screws are used at the front and the back. This design is different from Figure 2.B.6 in that the position and angle can be controlled very slowly by using the screws. This design is also a decoupled design as follows:

$$\begin{bmatrix} FR_1 \\ FR_2 \end{bmatrix} = \begin{bmatrix} X & 0 \\ X & X \end{bmatrix} \begin{bmatrix} DP_1 \\ DP_2 \end{bmatrix} \tag{2.B.4}$$

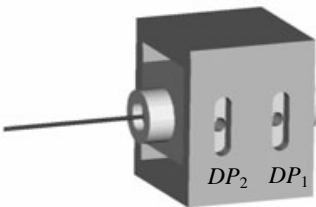

Figure 2.B.6. Design 1

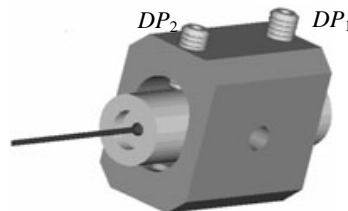

Figure 2.B.7. Design 2

The above two designs show a method to make a decoupled design by defining new design parameters. The method can be expanded for other DPs.

Figure 2.B.8 is the expansion of Figure 2.B.7. Five FRs are the same as before and DPs for Figure 2.B.8 are as follows:

- DP_1 : Upper rear screw
- DP_2 : Upper front screw
- DP_3 : Side rear screw
- DP_4 : Side front screw
- DP_5 : Fixing screw

DP_3 and DP_4 are similar to the aforementioned DP_1 and DP_2 . We can think of two designs in Figure 2.B.6 and Figure 2.B.7. DP_3 and DP_4 of Figure 2.B.8 are selected in the same manner as in Figure 2.B.7. The expanded design is also a decoupled design as

$$\begin{bmatrix} FR_1 \\ FR_2 \\ FR_3 \\ FR_4 \\ FR_5 \end{bmatrix} = \begin{bmatrix} X & 0 & 0 & 0 & 0 \\ X & X & 0 & 0 & 0 \\ 0 & 0 & X & 0 & 0 \\ 0 & 0 & X & X & 0 \\ 0 & 0 & 0 & 0 & X \end{bmatrix} \begin{bmatrix} DP_1 \\ DP_2 \\ DP_3 \\ DP_4 \\ DP_5 \end{bmatrix} \quad (2.B.5)$$

Therefore, the new designs satisfy the Independence Axiom. Using various new ideas, we can create other designs that satisfy the Independence Axiom.

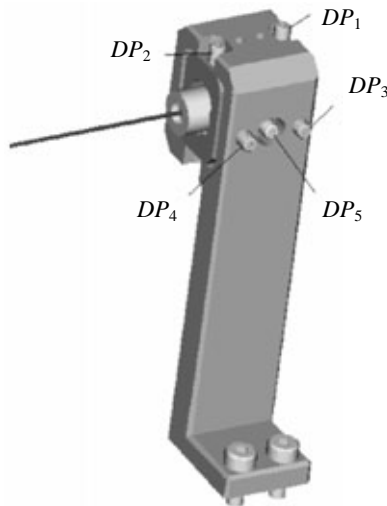

Figure 2.B.8. Final design

Selection of the Final Design Using the Information Axiom

The Information Axiom is utilized to select the best design out of multiple designs satisfying the Independence Axiom. The probability of success is considered as the information content. The relationship between the FRs and DPs should be expressed by explicit functions to evaluate the information content. The two designs in Figure 2.B.9 are compared for the information content.

In model #1 of Figure 2.B.9, the movement of the DP is the same as the movement of the beam. Therefore, the slope (m) in Figure 2.B.10 is 1. On the other hand, the beam moves as much as a pitch when the screw rotates once in model #2. The relationship is

$$2\pi r \tan \theta = p \tag{2.B.6}$$

where r is the radius of the screw, θ is the angle of the screw and p is the pitch.

When the radius is 1.5 mm and the pitch is 1 mm, the slope is 0.106 as shown in Figure 2.B.10. Considering the environmental and geometrical aspects of a certain existing design, the design matrices of the two designs are as follows:

$$\text{Model \#1: } \begin{bmatrix} FR_1 \\ FR_2 \end{bmatrix} = \begin{bmatrix} 1 & 0 \\ -4 & 4 \end{bmatrix} \begin{bmatrix} DP_1 \\ DP_2 \end{bmatrix} \tag{2.B.7}$$

$$\text{Model \#2: } \begin{bmatrix} FR_1 \\ FR_2 \end{bmatrix} = \frac{1}{3\pi} \begin{bmatrix} 1 & 0 \\ -4 & 4 \end{bmatrix} \begin{bmatrix} DP_1 \\ DP_2 \end{bmatrix} \tag{2.B.8}$$

Suppose that the target $\mathbf{FR}^* = [0 \ 0]^T$ is satisfied by $\mathbf{DP}^* = [0 \ 0]^T$. The information content can be calculated when the target is achieved. The information content is calculated by the graphical method using Equation 2.40 or 2.41. Assume that $\Delta FR_1 = 0.2\text{mm}$ and $\Delta FR_2 = 0.3\text{rad}$. The tolerance of the design parameter is the tolerance when it is controlled by hand. Suppose

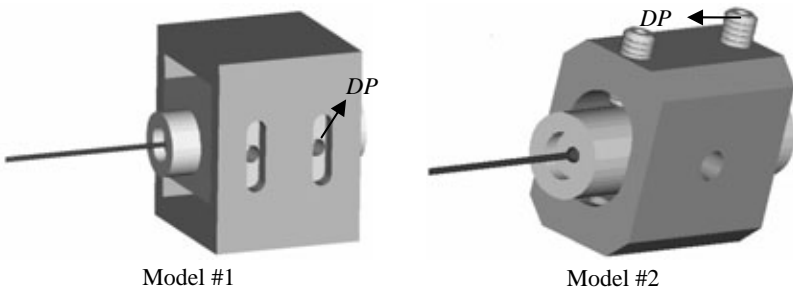

Figure 2.B.9. Design parameters for comparison of the information content

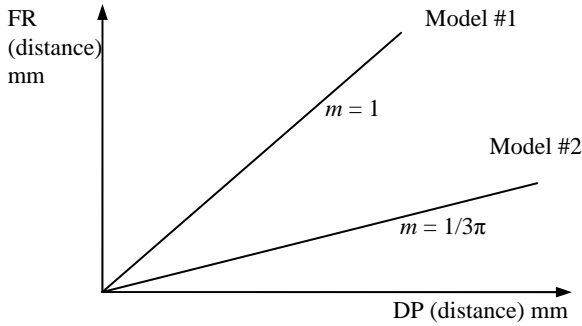

Figure 2.B.10. Slope of DP with respect to FR

$\Delta DP_i = 1\text{mm}$, $i = 1, 2$ have uniform distributions. The probability of success can vary according to the assumptions. In this case, the selection of a design is more important than the amount of the probability of success. Therefore, the above assumptions are valid for the selection.

The graphical method can be used in the same fashion as shown in Figure 2.13 or Figure 2.14. We use the integration method here. Using the unit step function in Figure 2.15, the probability distribution for each model is as

$$p_i = \frac{1}{2 \times 1} [u(\delta DP_i - (-\Delta DP_i)) - u(\delta DP_i - (\Delta DP_i))], \quad i = 1, 2 \quad (2.B.9)$$

Substituting Equations 2.B.7–2.B.9 into Equation 2.49, the probabilities of success p_{1s} and p_{2s} and the information contents I_1 and I_2 are

$$\text{Model \#1: } p_{1s} = 0.015, \quad I_1 = 6.059 \text{ (bits)}$$

$$\text{Model \#2: } p_{2s} = 0.582, \quad I_2 = 0.781 \text{ (bits)}$$

Therefore, model #2 is better than model #1. It is the same for the design of DP_3 and DP_4 . In conclusion, the design in Figure 2.B.8 is determined as the final design.

2.B.4 Summary

The flow of Figure 2.20 is applied to this problem as an example. Multiple designs are created based on the Independence Axiom and the final design is selected by the Information Axiom. As a result, an excellent design is made to overcome the weakness of the existing design (Shin and Park 2004).

2.C The Development of a Design System for a TV Glass Bulb

2.C.1 Problem Description

A glass bulb is the output device of a TV. It is an element of a TV tube and the tube is sometimes called a “brown tube.” A tube consists of a shadow mask, an electron gun, a band and a glass bulb. The glass bulb is composed of the panel (front glass) and the funnel (rear glass). Figure 2.C.1 presents the shape of the glass bulb.

In conventional design, the information flow of product design is carried via drawings. It is also inefficient in that the design processes are performed in heterogeneous systems. To improve the process, a design software system is developed based on the axiomatic approach to improve the design process and to strengthen the information flow.

2.C.2 The Conventional Design Process for a Glass Bulb

The conventional design process is illustrated in Figure 2.C.2. The process is defined by functional requirements as follows:

FR_1 : Construct the basic information of the product.

FR_2 : Establish the product shape.

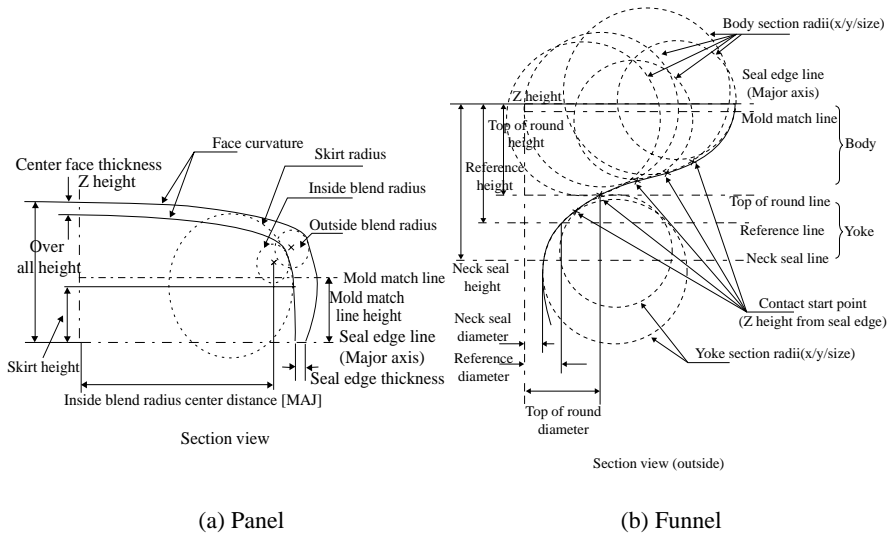

Figure 2.C.1. Shape of the glass bulb

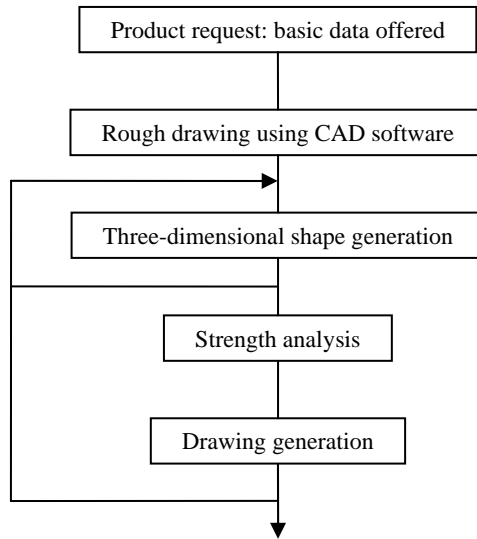

Figure 2.C.2. The conventional design process of the glass bulb

FR_3 : Verify the characteristics of the product.

FR_4 : Generate the product drawing.

The FRs are mapped into design parameters in the physical domain.

DP_1 : A set of basic data

DP_2 : The three-dimensional shape structure for the panel and the funnel

DP_3 : Loading conditions for the panel and the funnel

DP_4 : A set of drawing data

The relationship between FRs and DPs is

$$\begin{bmatrix} FR_1 \\ FR_2 \\ FR_3 \\ FR_4 \end{bmatrix} = \begin{bmatrix} X & 0 & 0 & X \\ X & X & 0 & X \\ X & X & X & X \\ X & X & 0 & X \end{bmatrix} \begin{bmatrix} DP_1 \\ DP_2 \\ DP_3 \\ DP_4 \end{bmatrix} \tag{2.C.1}$$

FR_1 is enabled by the basic data and drawings given by a customer. In the same manner, FR_4 is enabled by the basic data, the three-dimensional shape data and drawings. Therefore, FR_1 and FR_4 are coupled in the conventional design process.

2.C.3 Automatic Design Software for Product Design

The FRs are redefined based on the axiomatic approach.

FR_1 : Construct the database for a new product.

FR_2 : Establish the product shape.

FR_3 : Verify the characteristics of the product.

FR_4 : Generate the product drawing.

The corresponding DPs are

DP_1 : A set of data for the new product

DP_2 : The three-dimensional shape structure for the panel and the funnel

DP_3 : Loading conditions for the panel and the funnel

DP_4 : A set of accessory drawing data

The design matrix is a decoupled one as follows:

$$\begin{bmatrix} FR_1 \\ FR_2 \\ FR_3 \\ FR_4 \end{bmatrix} = \begin{bmatrix} X & 0 & 0 & 0 \\ X & X & 0 & 0 \\ X & X & X & 0 \\ X & X & 0 & X \end{bmatrix} \begin{bmatrix} DP_1 \\ DP_2 \\ DP_3 \\ DP_4 \end{bmatrix} \quad (2.C.2)$$

If DP_1 and DP_2 are determined FR_3 can be accomplished by using a commercial structural analysis program. Thus, FR_3 can be achieved by an independent module (M3). Other functional requirements can be decomposed based on the selected DP.

FR_1 is decomposed as follows:

FR_{11} : Assign an ID number to a new product.

FR_{12} : Construct a set of data for a new product.

FR_2 and FR_4 are decomposed as follows:

FR_{21} : Check the curvature (panel: flatness, funnel: axis profile).

FR_{22} : Calculate the three-dimensional shape.

FR_{23} : Consider the manufacturability.

FR_{41} : Represent the shape of the product.

FR_{42} : Display the accessory of the drawing.

The selected design parameters and the design matrix are as follows:

DP_{11} : Representative code of the new product

DP_{12} : A set of specific data for the new product

$$\begin{bmatrix} FR_{11} \\ FR_{12} \end{bmatrix} = \begin{bmatrix} X & 0 \\ X & X \end{bmatrix} \begin{bmatrix} DP_{11} \\ DP_{12} \end{bmatrix} \quad (2.C.3)$$

Since the ID number of a new product is used before making the specific product data, the design matrix in Equation 2.C.3 is a decoupled one. The design parameters for FR_{21} , FR_{22} and FR_{23} and the design matrix are as follows:

DP_{21} : Inside/outside curvature of the product

DP_{22} : The characteristic geometric equation of the product

DP_{23} : A set of data for the mold

$$\begin{bmatrix} FR_{21} \\ FR_{22} \\ FR_{23} \end{bmatrix} = \begin{bmatrix} X & 0 & 0 \\ X & X & 0 \\ X & X & X \end{bmatrix} \begin{bmatrix} DP_{21} \\ DP_{22} \\ DP_{23} \end{bmatrix} \quad (2.C.4)$$

DP_{23} for FR_{23} is not specific; therefore, it should be decomposed.

The design parameters for FR_{41} and FR_{42} are as follows:

DP_{41} : A set of data for product design

DP_{42} : A set of data for the accessory

The design matrix is

$$\begin{bmatrix} FR_{41} \\ FR_{42} \end{bmatrix} = \begin{bmatrix} X & 0 \\ 0 & X \end{bmatrix} \begin{bmatrix} DP_{41} \\ DP_{42} \end{bmatrix} \quad (2.C.5)$$

FR_{23} can be decomposed as follows:

FR_{231} : Check the useful screen dimension for the panel.

FR_{232} : Consider the ejectability.

FR_{233} : Examine the deflection angle of a scanning line for the funnel.

The corresponding design parameters are as follows:

DP_{231} : Distance of the blending circle center position

DP_{232} : Angle of the side wall

DP_{233} : Inside curvature of the yoke part

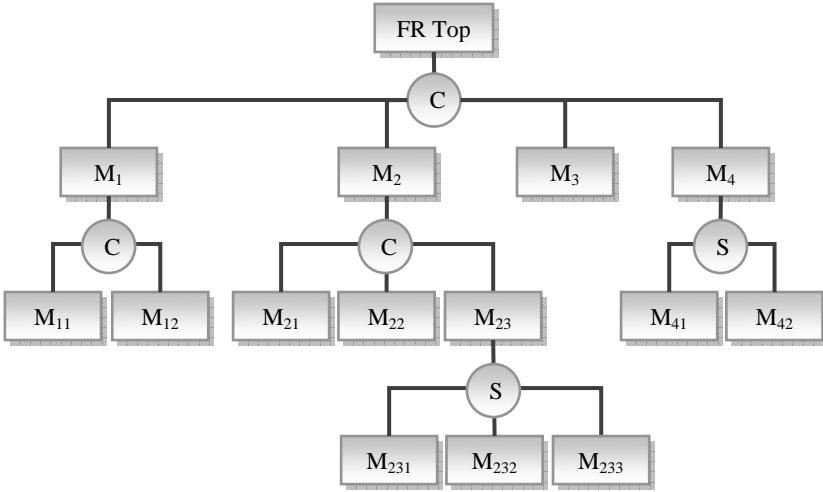

Figure 2.C.3. Module junction structure diagram of the design system for the TV glass bulb

The design matrix is

$$\begin{bmatrix} FR_{231} \\ FR_{232} \\ FR_{233} \end{bmatrix} = \begin{bmatrix} X & 0 & 0 \\ 0 & X & 0 \\ 0 & 0 & X \end{bmatrix} \begin{bmatrix} DP_{231} \\ DP_{232} \\ DP_{233} \end{bmatrix} \tag{2.C.6}$$

The lower level of FR_{23} is a uncoupled design; therefore, the lower level of FR_2 is a decoupled design.

Figure 2.C.3 presents the module junction structure diagram. Figure 2.C.4 shows the information flow for the design. The dotted lines in Figure 2.C.4 do not represent the flow for feedback. This means a design change when the analysis results are not satisfactory.

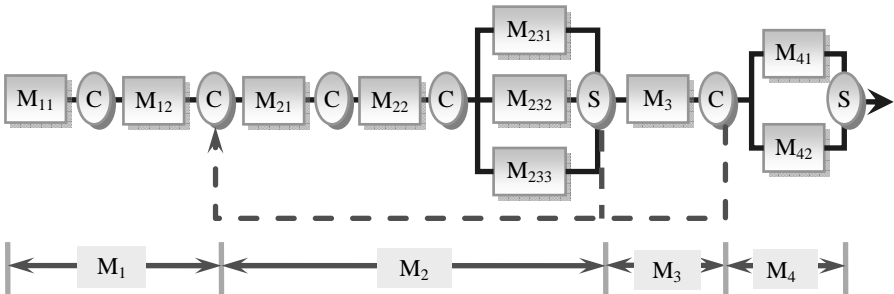

Figure 2.C.4. Information flow from Figure 2.C.3

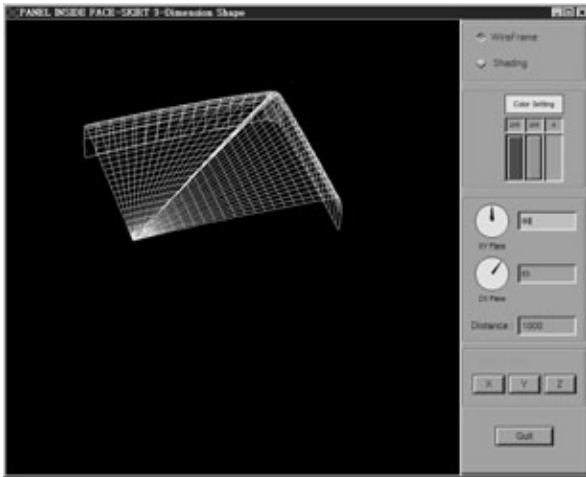

Figure 2.C.6. Display of the three-dimensional shape

An in-house program called BULB-3D is employed for shape generation (Park *et al.* 1995). BULB-3D uses geometrical interrelations and some specific numerical algorithms. From the design variables, this module constructs the geometry of the glass bulb. To confirm the shape of the glass bulb, the designer may want to see the shape. The displays with the wire frame and surface modelling are obtained by a commercial graphics library and special display hardware. The Starbase

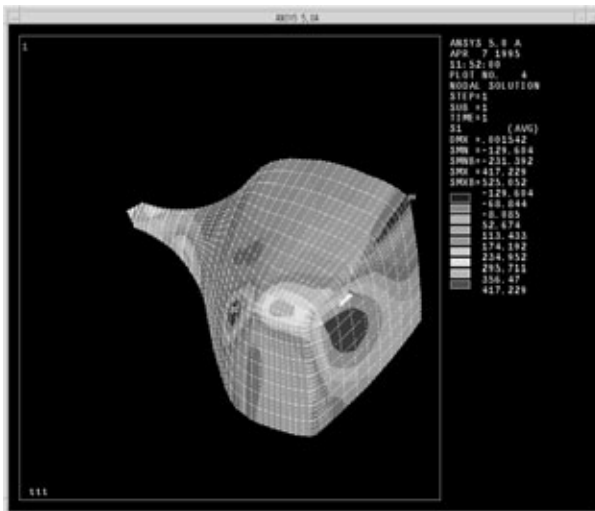

Figure 2.C.7. Display of the results from strength analysis

graphics library is used for this purpose (Hewlett-Packard Co. 1993). An example is illustrated in Figure 2.C.6.

Strength Analysis

After the three-dimensional shape is constructed, strength analysis is performed. A special mesh generation routine is used to generate an input file for strength analysis. The failure criterion uses the maximum normal stress theory. If the result of the strength analysis is not acceptable, an iterative process with the three-dimensional shape generation module is carried out. This process is shown as the dotted line in Figure 2.C.4. A commercial software system called ANSYS is employed for the strength analysis (ANSYS Inc. 1993). Results of the strength analysis are shown in Figure 2.C.7.

Drawing Generation

When all the activities are finished, the results are drawn. A commercial CAD (computer-aided design) system called Unigraphics is used (Electronic Data Systems Co. 1993). An example of the final drawing is illustrated in Figure 2.C.8.

2.C.5 Summary

The axiomatic design framework is applied to software development with a conventional language. The conventional design of the TV glass bulb is analyzed

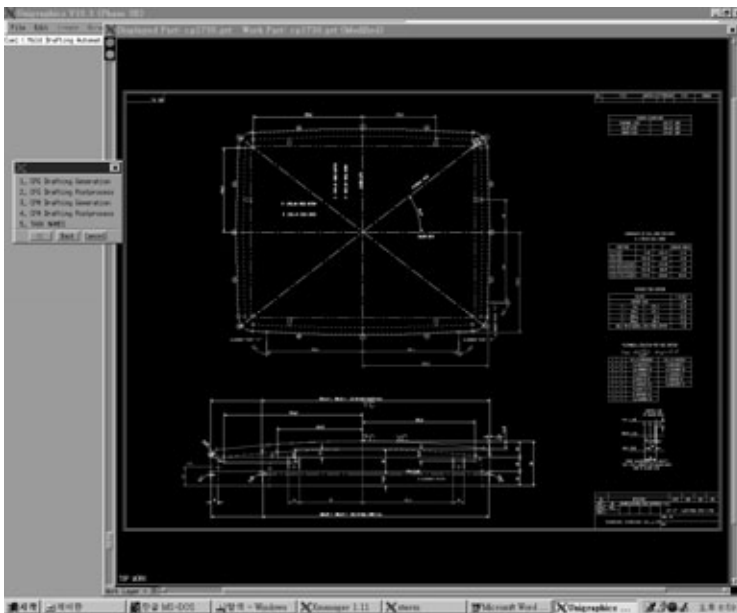

Figure 2.C.8. An example of the final drawing

and improved by the axiomatic approach. The approach uses the general methods defined in the axiomatic design, such as the zigzagging process, module junctions and system architecture for the flow. The software is designed based on the improved design process at the early stage of software development. It is noted that the flow of the software execution is the same as the design process.

2.D The Development of a Design System for the EPS Cushioning Package of a Monitor

2.D.1 Problem Description

A monitor is packed by cushioning materials because it may become damaged during transportation (Yi and Park 2005). The cushioning part of a monitor is mostly made of expanded polystyrene (EPS). Although it is lightweight, the usage of EPS considerably increases the volume of the packing box. Therefore, industries are trying to minimize the volume while maintaining the strength.

Currently, the cushioning package of monitors is designed based on past experience, not with a systematic approach. When a design is finished, the strength is validated by drop tests that are very expensive. If the design is not satisfied, an iterative process with trial and error is carried out. In recent years, software for computer simulated drop tests is used in the conceptual design stage. It is well known that flexible use of the software is quite difficult due to the tedious modelling procedure and tricky analysis skills required. Therefore, we need a software system that automatically analyzes and designs the cushioning package of monitors.

A software system is developed to construct the finite element (FE) model, to perform the simulation of the drop test and to automatically design the cushioning part. The FE model is automatically made by a commercial software LS/INGRID and the drop test is simulated by a software system LS/DYNA3D (Livermore Software Technology Co. 1998, 1999). The design process is established based on the axiomatic approach and the software system is designed accordingly. The Independence Axiom is utilized for the sequence of the design process and software design.

2.D.2 The Development of an Automatic Design System for the EPS Cushioning Package

The V-model and the steps introduced in Section 2.5.3 are utilized. An automatic design system is developed for conceptual and detailed designs. First, the conventional design method is investigated. Customer attributes (CAs) are defined by interviewing practical designers.

Definition of FRs for the System and Decomposition (Steps 1, 2 and 3)

The design process for an EPS cushioning package is analyzed from an axiomatic viewpoint. As a result, FRs, DPs and their relationships for the top level are defined as shown in Table 2.D.1. The design process is a decoupled one because the design matrix is triangular. Thus, the software design should be carried out according to the sequence that the design matrix indicates. As mentioned earlier, the decomposition is continued up to the minimum unit of the algorithms, that is, the minimum unit of methods.

Table 2.D.1. Top level FRs of the design system for the EPS cushioning package of a monitor

	FR_x	DM	DP_x
1	Set up the options	X O O O O	Option data
2	Construct the data set for modelling and simulation	X X O O O	Data for modelling and drop test
3	Generate an FEM model of the cushioning material	X X X O O	Design variables of cushioning material
4	Recommend a good design value through simulation analysis	X X X X O	DYNA3D input deck
5	Manage the design data	X X X X X	Data manager

Table 2.D.2. Decomposition of FR_2

	$FR_{2,x}$	DM	$DP_{2,x}$
	Construct the data set for modelling and simulation		Data for modelling and drop test
1	Construct modelling data for monitor	X O O	Modelling data for monitor
2	Construct modelling data for cushioning material	O X O	Modelling data for cushioning material
3	Construct condition data for drop test	O O X	Dropping condition

Table 2.D.3. Decomposition of FR_{21223} at the leaf level

	$FR_{21223,x}$	DM_{21223}	$DP_{21223,x}$
	Translate the files for nodes and elements into the DYNA format files		Files for nodes and elements
1	Read the files	X O O O	File names
2	Calculate the adding quantity	X X O O	Numbers of nodes and elements
3	Save the files in DYNA format	X X X O	DYNA format
4	Save the offset-number of nodes	O X O X	Offset number of nodes

As shown in Table 2.D.1, FR_2 is “construct the data set for modelling and simulation.” DP_2 is input data such as modelling of the monitor and input data for analysis. From DP_2 , the detailed operations of FR_2 are defined. That is, various data constructions should be made for the modelling data, analysis data and

material data. Therefore, FR_2 is decomposed as shown in Table 2.D.2. The decomposition continues until the leaf level is reached. An example of the bottom level is shown in Table 2.D.3. The flow of the software system is the same as that of the design process except for the options of the software system and data management.

Definition of Modules and Identification of Objects (Steps 4 and 5)

The entire full design matrix is established from the zigzagging process of the decomposition. The full design matrix is exploited for definition of software modules and objects. For example, Figure 2.D.1 illustrates the design matrix for FR_3 . The rectangular matrices with thick lines represent independent sub-matrices. Each FR is defined as a module and each module is defined in the functional domain, while each object is defined in the physical domain. Therefore, the design matrix shows the relationship between the functional domain and the physical domain.

The developed software modules consist of the main module, the data

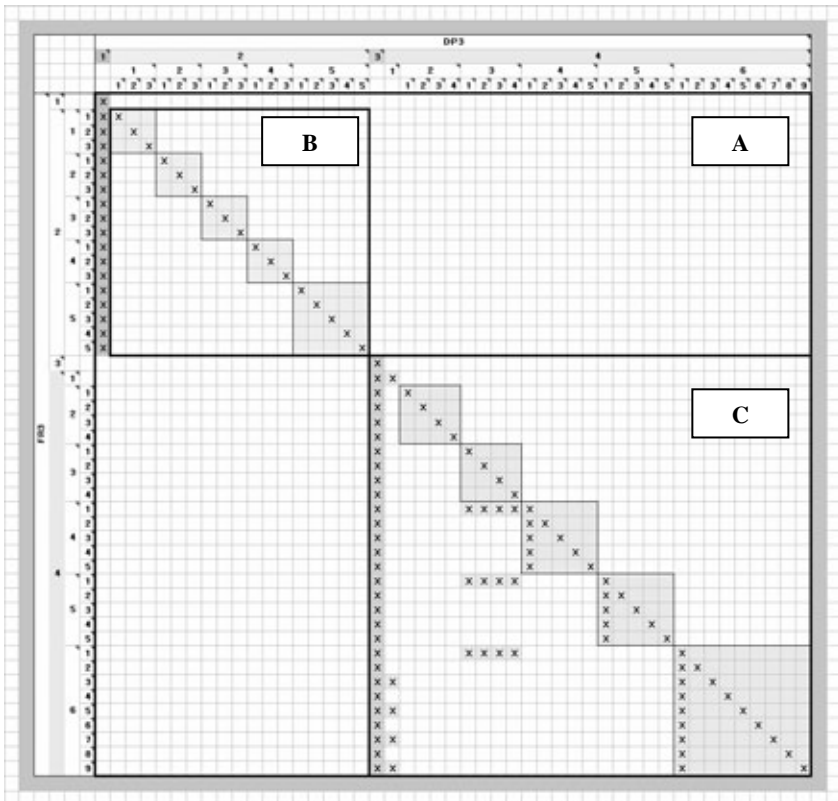

Figure 2.D.1. Design matrix of FR_3

management module, the module for modeling, the module for the drop test analysis and the module for automatic analysis and design. The main module controls the graphic user interface for input and the overall design process. The data management module has the function of managing the data for the system. It handles the interface with external systems, the files for material properties and the database for standard orthogonal arrays. The module for modelling generates the input data for analysis, which are shape sizes and the input file for LS/INGRID that automatically generates meshes for the finite element analysis. The module for the drop test generates an input file for the analysis system LS/DYNA3D and executes the system. The module for analysis and design performs the analysis, analyzes the results and proposes a new design.

Each module is defined as an object. An object consists of the functions in the row of the design matrix and the attributes of the column. For example, FR_3 in Figure 2.D.1 is defined by object A, which includes object B for inner shapes and object C for external shapes. Object B is composed of four objects for four positions from the user input and one object for common data. In the same manner, object C has five objects.

Establishment of Interfaces and Coding (Steps 6 and 7)

Classes are defined by the set of objects as illustrated in Figure 2.D.2. The classes in the low levels are not presented in Figure 2.D.2. The class “PackDesign” is defined from the relation of the four classes. The class “Option” has a function of input for initial definition. It is automatically executed when the system starts. The class “BasicModel” handles the data for the monitor and material properties

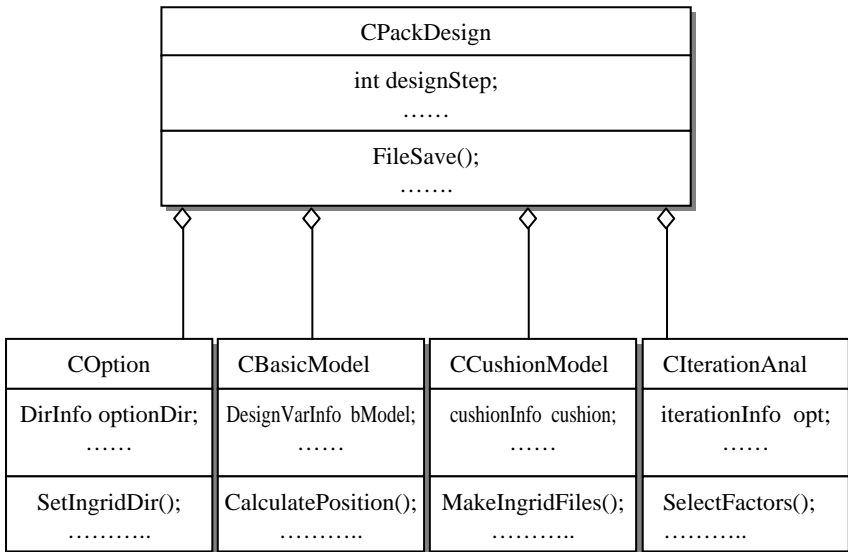

Figure 2.D.2. Class diagram of the “PackDesign” software system

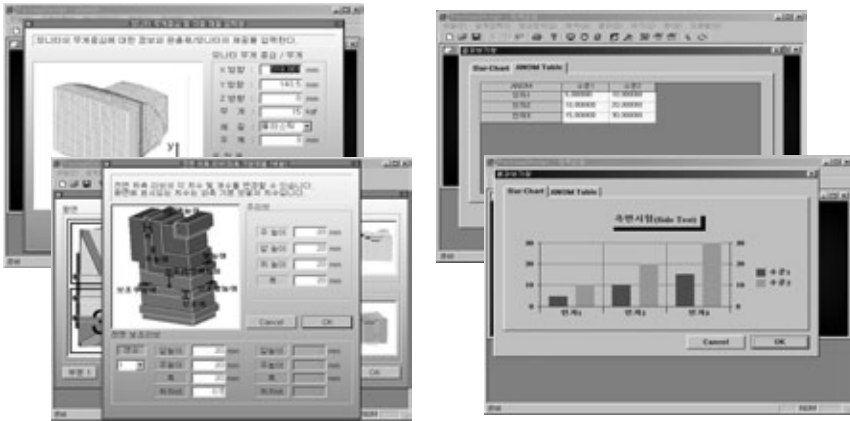

Figure 2.D.3. The output screen of the “PackDesign”

and the class “CushionModel” handles the shapes of the cushioning materials. They receive data from a user, perform coordinate transformation and generate the input file for the finite element analysis. Finally, the class “IterationAnal” selects an orthogonal array, performs the drop tests according to the orthogonal array and analyzes the results. If the aforementioned basic model is varied, derived classes can be made by inheritance from the classes “BasicModel” and “CushionModel.”

Using the above process, a software system is coded. The overall menus are illustrated in Figure 2.D.3. The left hand side is for input and the right hand side is for displaying results. The execution of the system is classified into two modes. One is analysis with given parameters and the other is a design process for multiple analyses with changing variables.

2.D.3 Summary

The axiomatic approach for software design is demonstrated. Software is developed based on the V-model which is related to the object oriented programming concept. The developed software can be easily used by new engineers. The design results are stored in the database and exploited for later use.

References

- Albano LD, Suh NP (1992) Axiomatic Approach to Structural Design. Research in Engineering Design 1(4):171–183
- Albano LD, Suh NP (1993) The Information Axiom and Its Implication. DE–Vol 66, Intelligent Concurrent Design: Fundamentals, Methodology, Modeling and Practice, ASME
- ANSYS Inc. (2004) ANSYS User’s Manual Version 8.1. Canonsburg, PA

- Do SH, Park GJ (2001) Application of Design Axioms for Glass Bulb Design and Software Development for Design Automation. *Journal of Mechanical Design, Transactions of the ASME* 123(3):322–329
- Do SH, Suh NP (2000) Axiomatic Design of Software Systems. *CIRP Annals* 49(1):95–100
- Electronic Data Systems Co., (1993) *User Function Programming Manual*. Livonia, MI
- El-Haik B, Yang K (1999) The Components of Complexity in Engineering Design. *IIE Transactions* 31:925–934
- Frey DD, Jahangir E, Engelhardt F (2000) Computing the Information Content of Decoupled Designs. *Research in Engineering Design* 12:90–102
- Gebala DA, Suh NP (1992) An Application of Axiomatic Design. *Research in Engineering Design* 3:149–162
- Heller D, Ferguson PM (1994) *Motif Programming Manual*. O'Reilly & Associates, Setastopol, CA
- Hewlett–Packard Co. (1991) *Starbase Graphics Techniques*. TX
- Hwang KH, Lee KW, Park GJ (2001) Robust Optimization of an Automobile Rearview Mirror for Vibration Reduction. *Structural and Multidisciplinary Optimization* 21(4):300–308
- Kim SJ, Suh NP, Kim SK (1991) Design of Software Systems Based on Axiomatic Design. *Annals of CIRP*, 40(1): 165–170
- Lee J, Cho K, Lee K (1994) A New Control System of a Household Refrigerator-Freezer. *International Refrigeration Conference*, Purdue University, IN
- Livermore Software Technology Co. (1998) *LS/INGRID Manual Ver. 3.5*. Livermore, CA
- Livermore Software Technology Co. (1998) *LS/DYNA Theory Manual*. Livermore, CA
- Livermore Software Technology Co. (1999) *LS/DYNA User's Manual Ver. 950*. Livermore, CA
- Mood AM, Graybill FA, Boes DC (1963) *Introduction to the Theory of Statistics*. 3rd ed. McGraw–Hill, New York
- NSF (1998) *Axiomatic Design Workshop for Professors*. MIT, Cambridge, MA
- Oracle Co., (1990) *ORACLE 3GL Programmers Guide*. Redwood Shore, CA
- Park GJ, Do SH, Lee JW, (1995) *Construction of Automatic Design Systems*. Final Report, Samsung Corning Co. (in Korean)
- Phadke MS (1989) *Quality Engineering Using Robust Design*. Prentice Hall, Englewood Cliffs, NJ
- Rinderle JR, Suh NP (1982) Measures of Functional Coupling in Design. *Transactions of ASME, Journal of Engineering for Industry* 104:383–388
- Shin GS, Park GJ (2004) *Supplementary Beam Adjuster for a Laser Device*. Patent No. 10-045398, Korea
- Shin MK, Hong SW, Park GJ (2001) Axiomatic Design of the Motor-Driven Tilt/Telescopic Steering System for Safety and Vibration. *Proceedings of the Institution of Mechanical Engineers, Part D, Journal of Automobile Engineering* 215(2):179–187
- Suh NP (1990) *The Principles of Design*. Oxford University Press, New York

- Suh NP (1995) Axiomatic Design of Mechanical Systems. Special 50th Anniversary, Combined Issue of the Journal of Mechanical Design and the Journal of Vibration and Acoustics, ASME 17:1–10
- Suh NP (1995) Designing-in of Quality through Axiomatic Design. IEEE Transactions on Reliability 44(2):256–264
- Suh NP (1995) Design and Operation of Large Systems. Journal of Manufacturing Systems 14(3):203–213
- Suh NP (1998) Axiomatic Design Theory for Systems. Research in Engineering Design 10:189–209
- Suh NP (1999) A Theory of Complexity, Periodicity and the Design Axioms. Research in Engineering Design 11:116–131
- Suh NP (2000) Axiomatic Design: Advances and Applications. Oxford University Press, New York
- Suh NP, Bell AC, Gossard DC (1978) On an Axiomatic Approach to Manufacturing and Manufacturing Systems. Journal of Engineering for Industry 100(2):127–130
- Suh NP, Sekimoto S. (1990) Design of Thinking Design Machine. Annals of the CIRP 39(1):145–148
- Suh NP, Wilson DR, Tice WW, Yasuhara M, Bell AC (1979) Application of Axiomatic Design Techniques to Manufacturing. Winter Annual Meeting, ASME 79-WA/Prod-25, New York, December 2–7
- Taguchi G (1987) Systems of Experimental Design. Kraus International Publications, New York
- Yi JW, Park GJ (2005) Development of a Design System for EPS Cushioning Package of a Monitor Using Axiomatic Design. Advances in Engineering Software 36:273–284

