

The Electrical Double Layer and Its Structure

Zbigniew Stojek

1.1.1 Introduction

At any electrode immersed in an electrolyte solution, a specific interfacial region is formed. This region is called the double layer. The electrical properties of such a layer are important, since they significantly affect the electrochemical measurements. In an electrical circuit used to measure the current that flows at a particular working electrode, the double layer can be viewed as a capacitor. Fig. I.1.1 depicts this situation where the electrochemical cell is represented by an electrical circuit and capacitor C_d corresponds to the differential capacity of

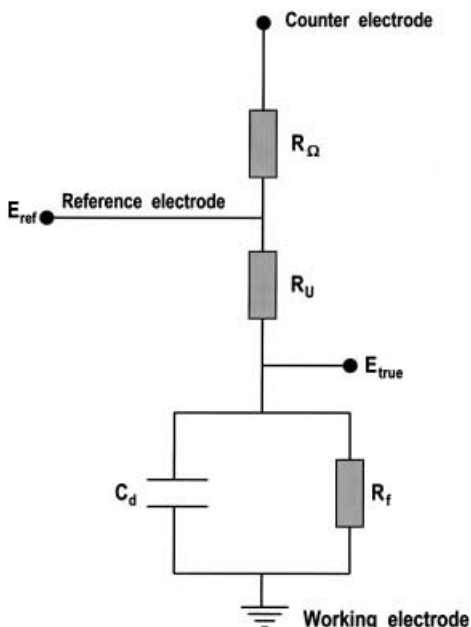

Fig. I.1.1. A simple electronic scheme equivalent to the electrochemical cell. R_u resistance uncompensated in the regular three-electrode system; C_d differential capacity of the double layer; R_f resistance to faradaic current at the electrode surface, R_Ω solution resistance compensated in the three-electrode system

the double layer. To obtain a desired potential at the working electrodes, the double-layer capacitor must be first appropriately charged, which means that a capacitive current, not related to the reduction or oxidation of the substrates, flows in the electrical circuit. While this capacitive current carries some information concerning the double layer and its structure, and in some cases can be used for analytical purposes, generally, it interferes in electrochemical investigations. A variety of ways are used in electrochemistry to depress, isolate or filter the capacitive current.

Although many models for the double layer have been published in the literature, there is no general model that can be used in all experimental situations. This is because the double-layer structure and its capacity depend on several parameters such as: electrode material (metals, carbons, semiconductors, electrode porosity, the presence of layers of either oxides or polymeric films or other solid materials at the surface), type of solvent, type of supporting electrolyte, extent of specific adsorption of ions and molecules, and temperature.

The composition of the double layer influences the electron transfer rate (see Chap. I. 3.1.5). Some ions and molecules specifically adsorbed at the electrode surface enhance the rate of the electrode process. In such a situation we talk about heterogeneous electrocatalysis. On the other hand, there are numerous compounds which, after adsorption, decrease the electron transfer rate and therefore are simply inhibitors. Some surface-active compounds can be very strongly adsorbed. This may lead to the total isolation of the electrode surface and, finally, to the disappearance, or substantial decrease, of the voltammetric peaks or waves.

An imposition of a potential from an external source (potentiostat/voltammograph) to a metallic electrode results in generation of a charge, σ_M , on the metal, and a charge σ_s in the solution. The charge at the electrode is related directly to the interfacial (double layer) capacity or capacitance. There are two ways to describe the capacity of an electrode:

- the differential capacitance, C_d , which naturally is at the minimum for the potential of zero charge, and which is represented by Eq. (I.1.1):

$$C_d = \frac{\partial \sigma_M}{\partial E} \quad (\text{I.1.1})$$

- and the integral capacitance, C_i , described by Eq. (I.1.2).

$$C_i = \frac{\sigma_M}{E - E_{\sigma=0}} \quad (\text{I.1.2})$$

The excess charge on the metallic electrode, σ_M , is a function of the electrode potential. The simplest equation that describes the charge on the metal is given for mercury electrodes. This is because the excess charge strongly affects the surface tension of mercury, and the latter can be easily measured experimentally. One simple method to measure the surface tension vs potential is to measure the drop time of a mercury-dropping electrode immersed in an electrolyte solution. The surface tension of mercury plotted vs potential usually gives a parabolic

curve. The maximum of this curve is located at the potential of zero charge, $E_{\sigma=0}$, since:

$$-\sigma_M = \frac{\partial \gamma}{\partial E} \quad (\text{I.1.3})$$

and the derivative of the surface tension equals 0 at the maximum. The differential capacity, C_d , reaches its minimum also at the potential of zero charge, a fact that can be concluded from a simple inspection of Eq. (I.1.1).

I.1.2 Double-Layer Models

The concept of the existence of the double layer at the surface of a metal being in contact with an electrolyte appeared in 1879 (Helmholtz). That first theoretical model assumed the presence of a *compact layer* of ions in contact with the charged metal surface. The next model, of Gouy and Chapman, involves a *diffuse double layer* in which the accumulated ions, due to the Boltzmann distribution, extend to some distance from the solid surface. In further developments, Stern (1924) suggested that the electrified solid-liquid interface includes both the rigid Helmholtz layer and the diffuse one of Gouy and Chapman. Specific adsorption of ions at the metal surface was pointed out by Graham in 1947. In consecutive developments, the role of the solvent has been taken into account (Parsons 1954; Bockris 1963). It soon became clear that in dipolar solvents, such as water, the dipoles must interact with the charged metal surface. It is also worth noting here that these interactions are promoted by the high concentration of the solvent, which is usually at least several moles per liter, and, in particular, for water it is around 55.5 M. In his theory, Parsons recognized that the dielectric constant of the solvent in the compact layer of adsorbed molecules is much lower compared to the outer region and approaches the limiting Maxwell value. A detailed description of the double-layer models mentioned above can be found in the literature [1–4].

A classic, simplified model of the double layer formed at the metal electrode surface is presented in Fig. I.1.2. There is a layer of adsorbed water molecules on the electrode surface. Since it has been assumed that there is excess of negative charge at the metal phase, the hydrogen atoms of adsorbed water molecules are oriented towards the metal surface. However, it is not a prerequisite that all water molecules at a particular electrode potential and the corresponding excess charge have the same orientation. For excess of positive charge at the metal surface, the dipoles of water will have different orientation. A specifically adsorbed large neutral molecule is also shown in Fig. I.1.2. This molecule has removed some water molecules from the surface. On the other hand, a hydrated cation present at the surface has not removed surface water, and therefore cannot be considered as specifically adsorbed.

Two planes are usually associated with the double layer. The first one, the inner Helmholtz plane (IHP), passes through the centers of specifically adsorbed ions (compact layer in the Helmholtz model), or is simply located just behind the

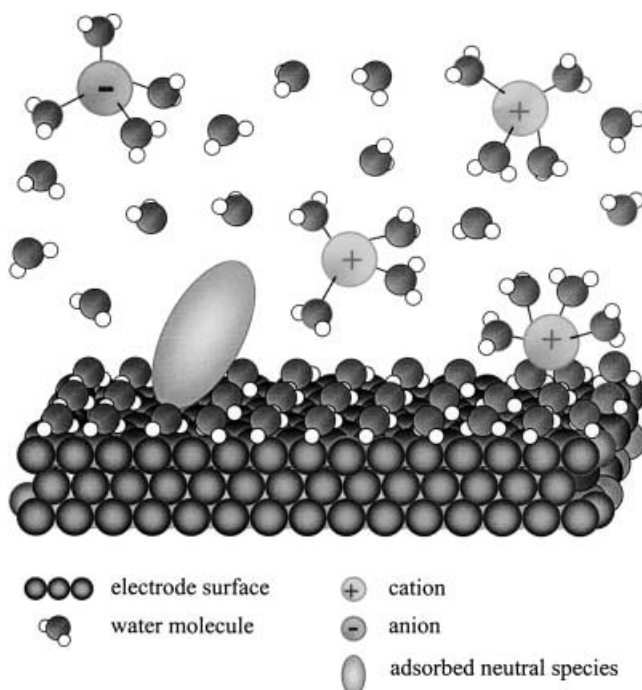

Fig. I.1.2. General representation of the double layer formed at the metal–electrolyte interface

layer of adsorbed water. The second plane is called the outer Helmholtz plane (OHP) and passes through the centers of the hydrated ions that are in contact with the metal surface. The electric potentials linked to the IHP and OHP are usually written as Ψ_2 and Ψ_1 , respectively. The diffuse layer develops outside the OHP. The concentration of cations in the diffuse layer decreases exponentially vs the distance from the electrode surface. The hydrated ions in the solution are most often octahedral complexes; however, in the figure, they are shown as tetrahedral structures for simplification.

The change in the electric potential within the double layer is illustrated in Fig. I.1.3. It is assumed that the electrode is charged negatively. The electric potential, ϕ_M , is virtually constant throughout the metallic phase except for the layers of metal atoms located next to the solution, where a discontinuity in the metal structure takes place and the wave properties of the electron are exposed (the jellium model [1, 3]). This effect is much stronger in semiconductor electrodes, where the accessible electronic levels are more restricted [5].

At carbon electrodes, which are widely used in electrochemistry, the double layer develops too; however, these electrodes have some specific interfacial properties. The two main types of carbon electrodes: glassy carbon and highly oriented pyrolytic graphite (HOPG) and the recently introduced boron-doped diamond, differ much in the bulk and the surface structure. They also differ in electrochemical activity. Particularly large differences exist for the two surfaces of

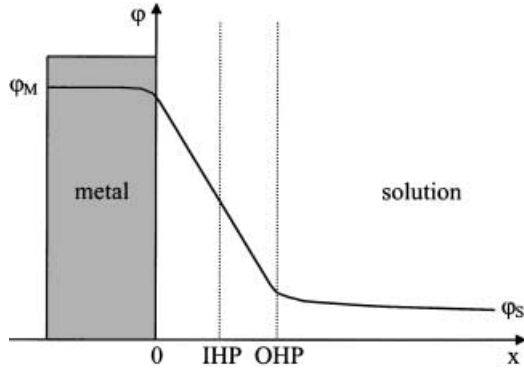

Fig. I.1.3. Potential profile in the double layer formed at a metallic electrode charged negatively

highly oriented pyrolytic graphite: the basal (hexagonal) and the edge one. At the edge plane, the electrode processes are usually much faster. An additional important factor for the electron transfer rate is the presence of oxygen at the surface. Oxygen easily chemisorbs on sp^2 carbon present in graphitic materials. This leads to the formation of many functional groups, mainly carbonyl, phenolic and carboxylate, and to an increase in the rate of the electrode processes. To reverse the chemisorption of oxygen, and to obtain, reproducibly, oxygen-free surfaces, is not easy. Neither is it easy to keep the surface oxygen-to-carbon ratio constant in the consecutive experiments. A positive aspect of the presence of the functional groups at the graphitic surfaces is that they make the chemical modification of the electrodes easier.

Details of the properties of carbon electrodes can be found in the literature [6].

I.1.3 Thickness of the Electric Double Layer

The thickness of the double layer is usually given as being approximately $1.5\kappa^{-1}$, where κ^{-1} is the Debye-Hückel length:

$$\kappa^{-1} = (\epsilon\epsilon_0 kT / 2c^0 z_1^2 e_0^2)^{1/2} \quad (\text{I.1.4})$$

where c^0 is the bulk $z_1 z_2$ electrolyte concentration, ϵ is the relative dielectric permittivity of the solvent, ϵ_0 is the permittivity of the vacuum, k is the Boltzmann constant, T is the temperature, z is the ion charge and e_0 is the elementary charge. For $z = 1$, the approximate κ^{-1} values calculated for electrolyte concentrations of 1×10^{-3} , 1×10^{-5} and 1×10^{-7} M are 10 nm, 100 nm and 1 μm , respectively. The thickness of the double layer also depends on the potential: the larger the difference between the electrode potential and the potential of zero charge (the potential at which the excess charge on the electrode equals zero), the smaller is the Debye-Hückel length.

I.1.4 Recent Developments

There is still much to do to be able to predict the behavior and the capacitance of the double layer in the entire available potential window and under all conditions. The introduction of rigorous theories that can take into account the various chemical and electrochemical properties of electrode materials, the specific adsorption of ions and neutral molecules and the dynamics of adsorbed solvent molecules and other adsorbates is not trivial. In consequence, there is still no satisfactory agreement between the experimental and theoretical data regarding capacitance of the double layer. Hopefully, the new experimental techniques, such as atomic force and scanning tunneling microscopies [7], and scanning electrochemical microscopy [8], will allow electrochemists to learn more about the structure of the double layer at the atomic level. On the theoretical side, the new digital methods of calculations provide a possibility to simulate, in time, all the changes within the double layer. The recent progress in the research on the solid-liquid electrochemical interfaces is given in, e.g., [9] and [10].

References

1. Brett CMA, Brett AMO (1993) *Electrochemistry: principles, methods, and applications*. Oxford Univ Press, Oxford
2. Bard AJ, Faulkner RF (2000) *Electrochemical methods*, 2nd edn. John Wiley, New York
3. Parsons R (1990) Electrical double layer: recent experimental and theoretical developments. *Chem Rev* 90: 813
4. Trasatti S (1985) In: Silva AF (ed) *Trends in interfacial electrochemistry*. Proceedings of NATO ASI (1984), Reidel, Dordrecht, pp 25–48
5. Morrison SR (1980) *Electrochemistry at semiconductor and oxidised metal electrodes*. Plenum, New York
6. McCreery RL (1999) Electrochemical properties of carbon surfaces. In: Wieckowski A (ed) *Interfacial electrochemistry. Theory, experiment, and applications*. Marcel Dekker, New York, pp 631–47
7. Moffat TP (1999) Scanning tunnelling microscopy studies of metal electrodes. In: Bard AJ, Rubinstein I (eds) *Electroanalytical chemistry*, vol 21. Marcel Dekker, New York
8. Bard AJ, Fan Fu-Ren, Mirkin MV (1994) Scanning electrochemical microscopy. In: Bard AJ, Rubinstein I (eds) *Electroanalytical chemistry*, vol 18. Marcel Dekker, New York
9. Jerkiewicz G (1997) From electrochemistry to molecular-level research on the solid-liquid electrochemical interface. An overview. In: Jerkiewicz G, Soriaga MP, Uosaki K, Wieckowski A (eds) *Solid-liquid electrochemical interfaces*. American Chemical Society, Washington
10. Philpott MR, Glosli JN (1997) Molecular dynamics simulation of interfacial electrochemical processes: electric double layer screening. In: Jerkiewicz G, Soriaga MP, Uosaki K, Wieckowski A (eds) *Solid-liquid electrochemical interfaces*. American Chemical Society, Washington